

# 一、多路阀系列 Hydraulic Directional Control Valves

## a、整体式多路阀 Monoblock Directional Control Valves

---

<b>a1</b>	P40系列 P40 Series .....	a1-a2
<b>a2</b>	Z50电磁控系列 Z50 Solenoid Control Valve .....	a3-a4
<b>a3</b>	P40系列电液控多路阀 P40 Electric and Hydraulic Control Valve .....	a5-a6
<b>a4</b>	P80系列 P80 Series .....	a7-a8
<b>a5</b>	P80电磁控系列 P80 Solenoid Control Valve .....	a9-a10
<b>a6</b>	P80系列电液控多路阀 P80 Electric and Hydraulic Control Valve .....	a11-a12
<b>a7</b>	RD5000系列 RD5000 Series .....	a13-a15
<b>a8</b>	HM2系列 HM2 Series .....	a16-a17
<b>a9</b>	HM3系列 HM3 Series .....	a18-a19
<b>a10</b>	HM3电磁控系列 HM3 Solenoid Control Valve .....	a20-a21
<b>a11</b>	HM7系列 HM7 Series .....	a22-a23
<b>a12</b>	HM10系列 HM10 Series.....	a24-a25
<b>a13</b>	HM9滑移式装载机专用阀系列 HM9 Series .....	a26-a27
<b>a14</b>	HM11系列 HM11 Series.....	a28-a29
<b>a15</b>	DCV20系列 DCV20 Series .....	a30-a31
<b>a16</b>	DCV40系列 DCV40 Series .....	a32-a33
<b>a17</b>	DCV40 气控系列 DCV40 Pneumatic Control Valve .....	a34-a35
<b>a18</b>	DCV40 电气控系列 DCV40 Electric and Pneumatic Control Valve .....	a36-a37
<b>a19</b>	DCV40 电液控系列 DCV40 Electric and Hydraulic Control Valve .....	a38-a39
<b>a20</b>	ZD-L102系列 ZD-L102 Series .....	a40-a41
<b>a21</b>	BDL-L40系列 BDL-L40 Series .....	a42-a43
<b>a22</b>	ZD-L15系列 ZD-L15 Series .....	a44-a45
<b>a23</b>	ZD-L15气控系列 ZD-L15 Pneumatic Control Valve .....	a46-a47
<b>a24</b>	ZD-L15电气控系列 ZD-L15 Electric and Pneumatic Control Valve .....	a48-a49

<b>a25</b>	ZDa-L15系列 ZDa-L15 Series .....	a50-a51
<b>a26</b>	ZDa-L15气控系列 ZDa-L15 Pneumatic Control Valve .....	a52-a53
<b>a27</b>	ZDa-L15电气控系列 ZDa-L15 Electric and Pneumatic Control Valve .....	a54-a55
<b>a28</b>	ZDa-L15电液控系列 ZDa-L15 Electric and Hydraulic Control Valve .....	a56-a57
<b>a29</b>	ZT-L20系列 ZT-L20 Series .....	a58-a59
<b>a30</b>	ZT-L20气控系列 ZT-L20 Pneumatic Control Valve .....	a60-a61
<b>a31</b>	ZT-L20电气控系列 ZT-L20 Electric and Pneumatic Control Valve .....	a62-a63

## b、分片式多路阀 Sectional Directional Control Valves

---

<b>b1</b>	HS4系列 HS4 Series .....	b1-b2
<b>b2</b>	HS4系列液控多路阀 HS4 Hydraulic Pilot Control Valve .....	b3-b4
<b>b3</b>	HS8系列 HS8 Series .....	b5-b6
<b>b4</b>	HS8系列液控多路阀 HS8 Hydraulic Pilot Control Valve .....	b7-b8
<b>b5</b>	HS9系列 HS9 Series .....	b9-b10
<b>b6</b>	HS9系列液控多路阀 HS9 Hydraulic Pilot Control Valve .....	b11-b12
<b>b7</b>	HS10系列 HS10 Series .....	b13-b14
<b>b8</b>	HS10系列液控多路阀 HS10 Hydraulic Pilot Control Valve .....	b15-b16
	DCV系列分体式多路阀如何订货及相关说明 .....	b17-28
	How to order DCV series sectional control valves	
<b>b9</b>	DCV60系列 DCV60 Series .....	b29-b35
<b>b10</b>	DCV100系列 DCV100 Series .....	b36-b41
<b>b11</b>	DCV140系列 DCV140 Series .....	b42-b45
	ZS系列参数 ZS Series Parameters .....	b46
	ZS1系列 ZS1 Series .....	b47
<b>b12</b>	ZS1-L10系列 ZS-L10 Series .....	b48
<b>b13</b>	ZS1-L15系列 ZS1-L15 Series .....	b49-b50

<b>b14</b>	ZS3系列 ZS3 Series .....	b51
<b>b15</b>	ZS3-L10系列 ZS-L10 Series .....	b52
<b>b16</b>	ZS3-L20系列 ZS-L20 Series .....	b53
	DL系列参数 DL Series Parameters .....	b54-b57
<b>b17</b>	DL-L15系列 DL-L15 Series .....	b58-b59
<b>b18</b>	SQDL-L15系列 SQDL-L15 Series .....	b60-b61
<b>b19</b>	YDL-L15系列 YDL-L15 Series .....	b62-b63
<b>b20</b>	DL-L20系列 DL-L20 Series .....	b64-b65
<b>b21</b>	SQDL-L20系列 SQDL-L20 Series .....	b66-b67
<b>b22</b>	YDL-L20系列 YDL-L20 Series .....	b68-b69
<b>b23</b>	DL-8系列 DL-8 Series .....	b70-b72
<b>b24</b>	DF-50系列 DF50 Series .....	b73-b75
	CDB系列参数 CDB Series .....	b76-b78
<b>b25</b>	CDB-F15系列 CDB-F15 Series .....	b79
<b>b26</b>	ZCDB-F15系列 ZCDB-F15 Series .....	b80-b81
<b>b27</b>	CDB-F20系列 CDB-F20 Series .....	b82
<b>b28</b>	ZCDB-F20系列 ZCDB-F20 Series .....	b83

## c、其他液压阀和配件 Other hydraulic control valves and hydraulic parts

---

<b>c1</b>	LKF系列流量控制阀 LKF Series Flow Control Valve .....	c1-c2
<b>c2</b>	SVV06电磁切换阀 SVV06 Solenoid Diverter Valve .....	c3-c4
<b>c3</b>	DVS90电磁切换阀 DVS90 Solenoid Diverter Valve .....	c5-c6
<b>c4</b>	SVV09电磁切换阀 SVV09 Solenoid Diverter Valve .....	c7-c8
<b>c5</b>	转阀 Rotary Spool Valve .....	c9-c11
<b>c6</b>	ZP80系列 ZP80 Series .....	c12-c13

# P40系列整体阀

## P40 Series Monoblock Directional Control Valves

### 用途与特征/APPLICATIONS&FEATURES

P40系列整体式多路阀是我公司引进欧洲的一种中高压整体式多路阀。可按客户要求可在阀上设溢流阀、单向阀。溢流阀可调节压力，单向阀防止油液倒流。换向阀的滑阀机能可有A,O,P,Y等，可任意组合，换向手柄有两种安装形式，便于不同方向的操作，该阀采用并联或者串联油路，设计有压力出口与其他液压元件相连接提供动力源。经过特殊设计的密封方式，使阀的密封性能卓越。该阀广泛应用于叉车、环卫车辆、小型装载机 etc 等工程机械的液压系统。



- ◆ P40 series valves with middle-high pressure monoblock construction is developed based on Europe technology.
- ◆ Inner check valve: The check valve inside the valve body is to insure the hydraulic oil not to be returned.
- ◆ Inner relief valve: The relief valve inside the valve body is able to adjust the hydraulic system working pressure.
- ◆ Oil way: Parallel circuit, power beyond option
- ◆ Control Way: Manual control, pneumatic control, hydraulic and electric control for optional.
- ◆ Valve construction: monoblock construction, 1-7 levers.
- ◆ Spool Function: O,Y, P,A.
- ◆ Option: Hydraulic lock is available to be added on A and B port.
- ◆ Available with manual, pneumatic control, electric and pneumatic control, hydraulic and electric control and etc.

### 型号说明/MODEL CODE



### 技术参数/PARAMETERS

公称压力 ( MPa ) Nom. Pressure	最大压力 ( MPa ) Max. Pressure	公称流量 ( L/min ) Nom. Flow rate	最大流量 ( L/min ) Max. Flow rate	中位背压 ( MPa ) Back Pressure	工作油液hydraulic oil		
					温度范围 ( °C ) Tem.rang	粘度范围 ( mm <sup>2</sup> /S ) Visc.rang	过滤精度 ( μm ) filtrating accuracy
20	31.5	40	40	≤1	-20 ~ +80	10 ~ 400	≤10

# P40 系列整体阀

## P40 Series Monoblock Directional Control Valves

### P40外形安装连接尺寸/MODEL P40 DIMENSIONAL DATA

a2

P40系列整体阀 MDCV

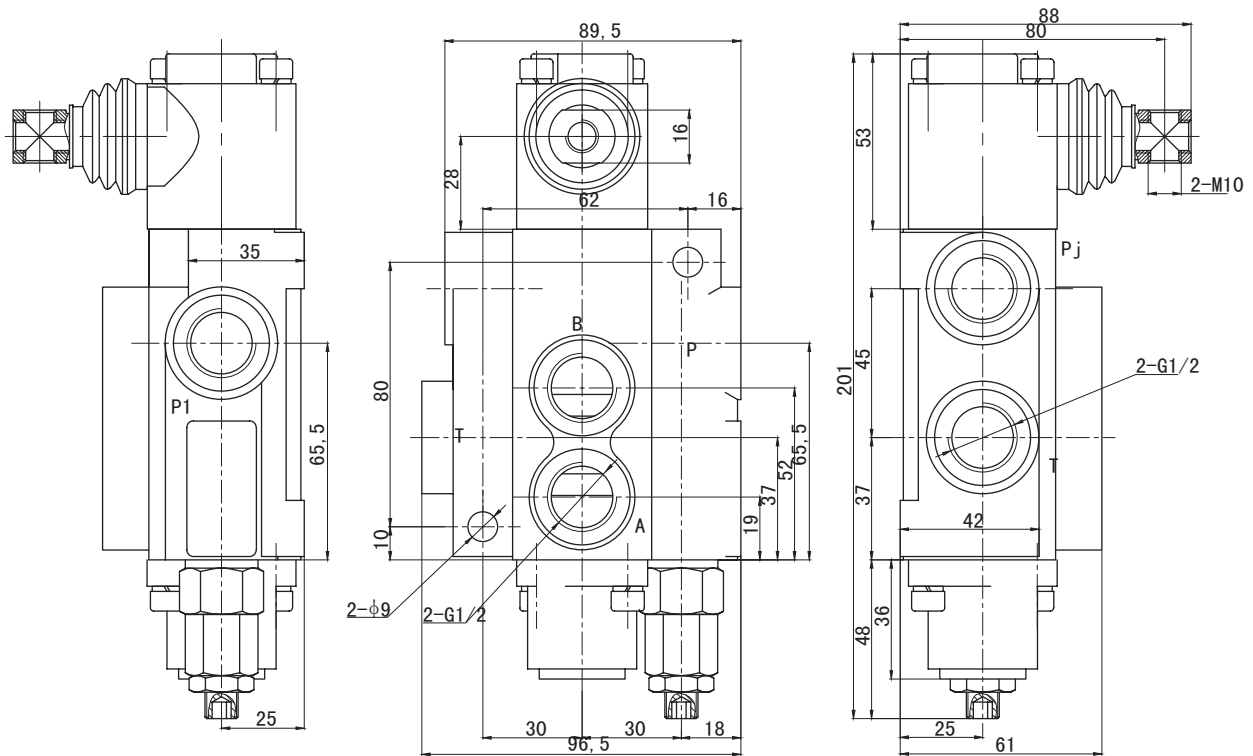

原理图

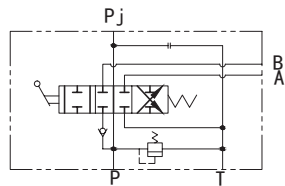

- 技术参数:
1. 公称压力 20MPa
  3. 额定流量 40L/min

注: 订货有特殊要求者, 请与销售顾问联系。  
Note: Special features not listed can often be made to your specifications. Please consult your sales representative.

# Z50 系列电磁控整体式多路阀

## Z50 Solenoid Control Valve

### 用途与特征/APPLICATIONS&FEATURES

Z50系列电磁控整体式多路阀是我公司引进欧洲的一种中高压、电磁阀控制的整体多路阀。该阀采用并联或者串联油路，设计有压力输出口与其他液压元件相连接提供动力源。经过特殊设计的密封方式，使阀的密封性能卓越。该阀广泛应用于叉车、环卫车辆、小型装载机等工程机械的液压系统。

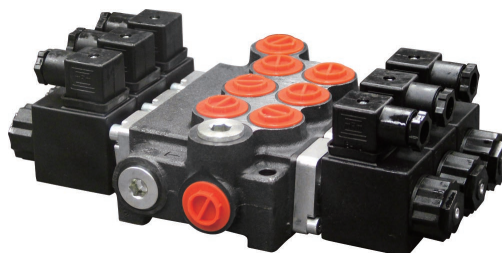

Z50 series valves with middle-high pressure monoblock construction is developed based on Europe technology.

The monoblock directional control valves-solenoid operated, offer perfect choice whether you are designing a new system or just simply trying to get more out of your current system. With two special spools and 7 different monoblock housings these valves can meet the specific needs of your application and hydraulic schemes by their double acting in 3 positions A and D spools.

◆ Inner check valve: The check valve inside the valve body is to insure the hydraulic oil will not be returned.

◆ Inner relief valve: The relief valve inside the valve body is able to adjust the hydraulic system working pressure.

◆ Oil way: Parallel circuit, power beyond option

◆ Coils, Connector ISO4400: 12VDC, 24VDC

◆ Threads: P,T-G1/2, SAE10, A,B-G3/8,SAE8

◆ Valve construction: Monoblock construction, 1-7 levers.

◆ Precise bore honing and spool grinding results in less cross-port leakage and less wasted energy.

These precise valves also allow for interchangeable spools for easy on place maintenance.

### 型号说明/MODEL CODE

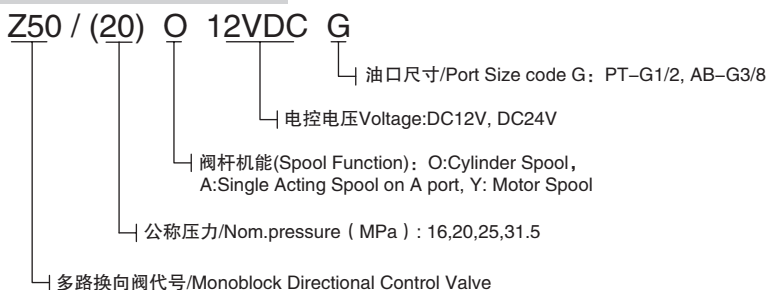

### 技术参数/PARAMETERS

公称压力 ( MPa ) Nom. Pressure	最大压力 ( MPa ) Max. Pressure	公称流量 ( L/min ) Nom. Flow rate	最大流量 ( L/min ) Max. Flow rate	中位背压 ( MPa ) Back Pressure	工作油液 hydraulic oil		
					温度范围 ( °C ) Tem.rang	粘度范围 ( mm <sup>2</sup> /S ) Visc.rang	过滤精度 ( μm ) filtrating accuracy
20	31.5	40	50	≤1	-20 ~ +80	10 ~ 400	≤1

# Z50 系列电磁控整体式多路阀

## Z50 Solenoid Control Valve

### Z50外形安装连接尺寸/MODEL Z50 DIMENSIONAL DATA

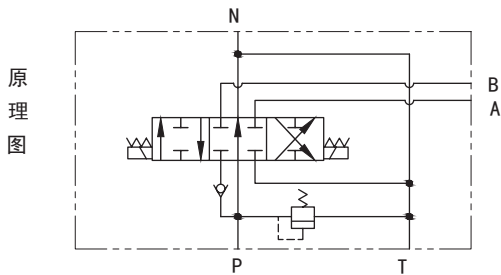
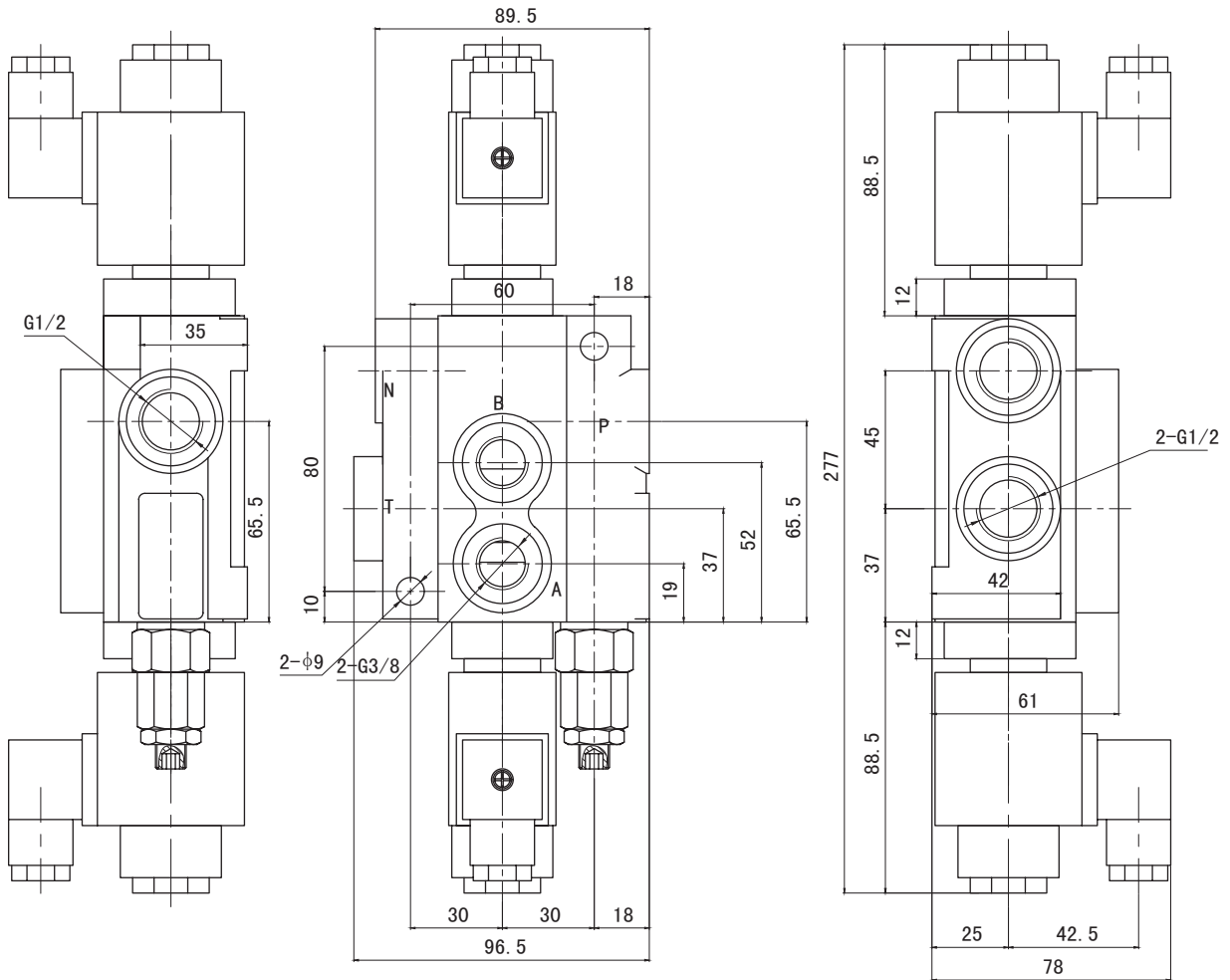

#### 技术参数:

1. 公称压力 20MPa
2. 额定流量 40L/min
3. 控制电压 DC12V

注: 订货有特殊要求者, 请与销售顾问联系。

Note: Special features not listed can often be made to your specifications. Please consult your sales representative.

a4

Z50系列电磁控整体式多路阀 MDCV

# P40 系列电液控多路阀

## P40 Electric and Hydraulic Control Valve

### 用途与特征/APPLICATIONS&FEATURES

P40系列整体式多路阀是我公司引进欧洲的一种中高压整体式多路阀。可按客户要求可在阀上设溢流阀、单向阀。溢流阀可调节压力，单向阀防止油液倒流。换向阀的滑阀机能可有A,O,P,Y等，可任意组合，换向手柄有两种安装形式，便于不同方向的操作，该阀采用并联或者串联油路，设计有压力出口与其他液压元件相连接提供动力源。经过特殊设计的密封方式，使阀的密封性能卓越。该阀广泛应用于叉车、环卫车辆、小型装载机 etc 等工程机械的液压系统。



P40 series valves with middle-high pressure monoblock construction is developed based on Europe technology.

- ◆ Inner check valve: The check valve inside the valve body is to insure the hydraulic oil will not be returned.
- ◆ Inner relief valve: The relief valve inside the valve body is able to adjust the hydraulic system working pressure.
- ◆ Oil way: Parallel circuit, power beyond option
- ◆ Control Way: Manual control, pneumatic control, hydraulic and electric control for optional.
- ◆ Valve construction: monoblock construction, 1-7 levers.
- ◆ Spool Function: O, Y, P, A.
- ◆ Option: Hydraulic lock is available to be added on A and B port.
- ◆ Available with manual, pneumatic control, electric and pneumatic control, hydraulic and electric control and etc.

### 型号说明/MODEL CODE

P40 / (20) - O D 1 U - .....



### 技术参数/PARAMETERS

公称压力 (MPa) Nom. Pressure	最大压力 (MPa) Max. Pressure	公称流量 (L/min) Nom. Flow rate	最大流量 (L/min) Max. Flow rate	中位背压 (MPa) Back Pressure	工作油液hydraulic oil		
					温度范围 (℃) Tem.rang	粘度范围 (mm <sup>2</sup> /S) Visc.rang	过滤精度 (μm) filtrating accuracy
20	31.5	40	50	≤1	-20 ~ +80	10 ~ 400	≤10

# P40 系列电液控多路阀

## P40 Electric and Hydraulic Control Valve

### P40外形安装连接尺寸/MODEL P40 DIMENSIONAL DATA

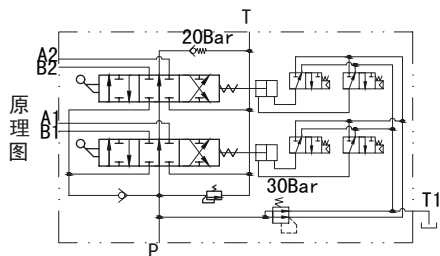
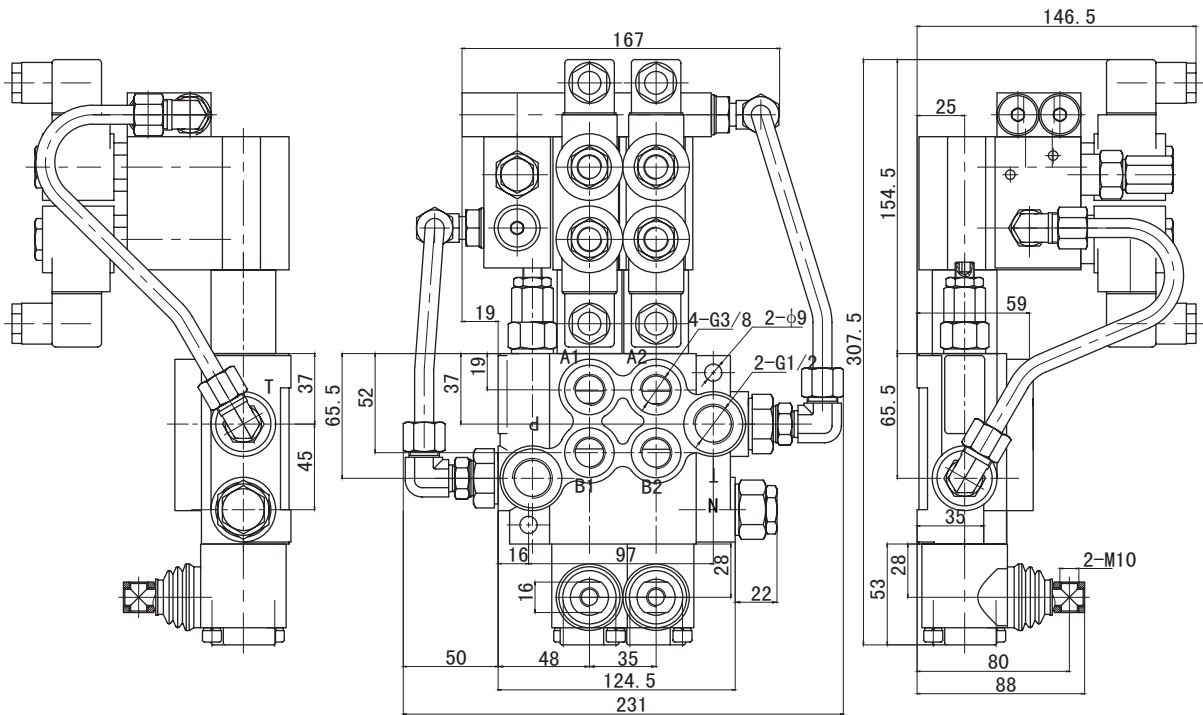

- 技术参数:
1. 公称压力 20MPa
  2. 额定流量 40L/min
  3. 控制电压为直流 DC12V/DC24V。

注: 订货有特殊要求者, 请与销售顾问联系。

Note: Special features not listed can often be made to your specifications. Please consult your sales representative.

a6

P40系列电液控多路阀 MDCV

# P80系列整体阀

## P80 Series Monoblock Directional Control Valves

### 用途与特征/APPLICATIONS&FEATURES

P80系列整体式多路阀是我公司引进欧洲的一种中高压整体式多路阀。可按客户要求可在阀上设溢流阀、单向阀。溢流阀可调节压力，单向阀防止油液倒流。换向阀的滑阀机能可有A,O,P,Y等，可任意组合，换向手柄有两种安装形式，便于不同方向的操作，该阀采用并联或者串联油路，设计有压力出口与其他液压元件相连接提供动力源。经过特殊设计的密封方式，使阀的密封性能卓越。该阀广泛应用于叉车、环卫车辆、小型装载机 etc 等工程机械的液压系统。



P80 series valves with middle-high pressure monoblock construction is developed based on Europe technology.

- ◆ Inner check valve: The check valve inside the valve body is to insure the hydraulic oil not to be returned.
- ◆ Inner relief valve: The relief valve inside the valve body is able to adjust the hydraulic system working pressure.
- ◆ Oil way: Parallel circuit, power beyond option
- ◆ Control Way: Manual control, pneumatic control, hydraulic and electric control for optional.
- ◆ Valve construction: monoblock construction, 1-6 levers.
- ◆ Spool Function: O,Y, P,A.
- ◆ Option:Hydraulic lock is available to be added on A and B port.
- ◆ Available manual, pneumatic control, electric and pneumatic control, hydraulic and electric control and etc.

### 型号说明/MODEL CODE



### 技术参数/PARAMETERS

公称压力 (MPa) Nom. Pressure	最大压力 (MPa) Max. Pressure	公称流量 (L/min) Nom. Flow rate	最大流量 (L/min) Max. Flow rate	中位背压 (MPa) Back Pressure	工作油液hydraulic oil		
					温度范围 (℃) Tem.rang	粘度范围 (mm <sup>2</sup> /S) Visc.rang	过滤精度 (μm) filtrating accuracy
20	31.5	80	80	≤1	-20 ~ +80	10 ~ 400	≤10

# P80 系列整体阀

## P80 Series Monoblock Directional Control Valves

### P80外形安装连接尺寸/MODEL P80 DIMENSIONAL DATA

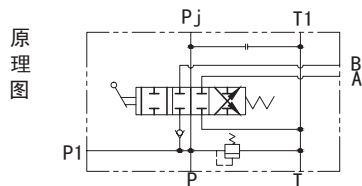
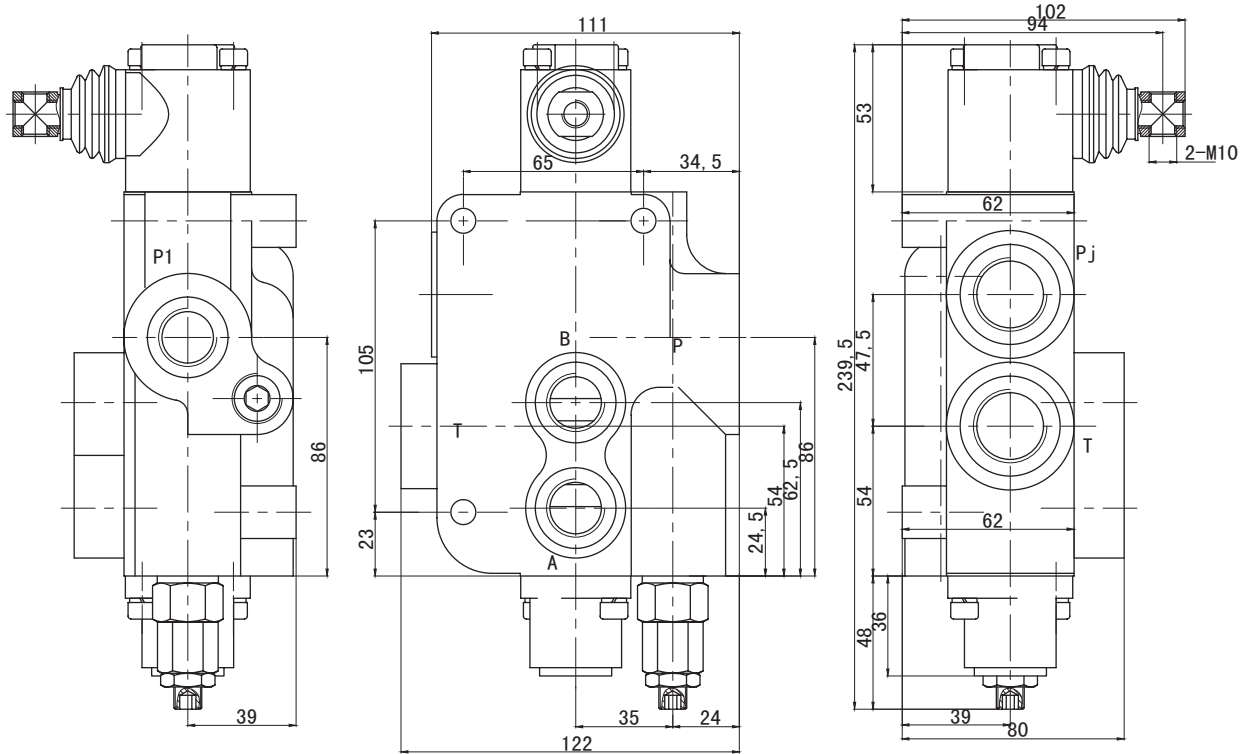

- 技术参数:
1. 公称压力 20MPa
  2. 额定流量 80L/min

注: 订货有特殊要求者, 请与销售顾问联系。  
 Note: Special features not listed can often be made to your specifications. Please consult your sales representative.

a8

P80系列整体阀 MDCV

# P80系列电磁控整体阀

## P80 Solenoid Control Valve

### 用途与特征/APPLICATIONS&FEATURES

P80系列电磁控整体式多路阀是我公司引进欧洲的一种中高压、电磁阀控制的整体多路阀。该阀采用并联或者串联油路，设计有压力输出口与其他液压元件相连接提供动力源。经过特殊设计的密封方式，使阀的密封性能卓越。该阀广泛应用于叉车、环卫车辆、小型装载机工程机械的液压系统。



P80 series valves with middle-high pressure monoblock construction is developed based on Europe technology.

◆ The monoblock directional control valves-solenoid operated, offer perfect choice whether you are designing a new system or just simply trying to get more out of your current system. With two special spools and 6 different monoblock housings these valves can meet the specific needs of your application and hydraulic schemes by their double acting in 3 positions A and D spools.

◆ Inner check valve: The check valve inside the valve body is to insure the hydraulic oil not to be returned.

◆ Inner relief valve: The relief valve inside the valve body is able to adjust the hydraulic system working pressure.

- ◆ Oil way: Parallel circuit, power beyond option
- ◆ Coils, Connector ISO4400: 12VDC, 24VDC
- ◆ Threads:P,A,B-G1/2, SAE10, T-G3/4,SAE12
- ◆ Valve construction: Monoblock construction, 1-6 levers.

Precise bore honing and spool grinding results in less cross-port leakage and less wasted energy. These precise valves also allow for interchangeable spools for easy on place maintainance.

### 型号说明/MODEL CODE

P80 / (20) O 12VDC G



### 技术参数/PARAMETERS

公称压力 (MPa) Nom. Pressure	最大压力 (MPa) Max. Pressure	公称流量 (L/min) Nom. Flow rate	最大流量 (L/min) Max. Flow rate	中位背压 (MPa) Back Pressure	工作油液hydraulic oil		
					温度范围 (℃) Tem.rang	粘度范围 (mm <sup>2</sup> /S) Visc.rang	过滤精度 (μm) filtrating accuracy
20	31	80	80	≤1	-20 ~ +80	10 ~ 400	≤10

# P80系列电磁控整体阀

## P80 Solenoid Control Valve

### P80外形安装连接尺寸/MODELR P80 DIMENSIONAL DATA

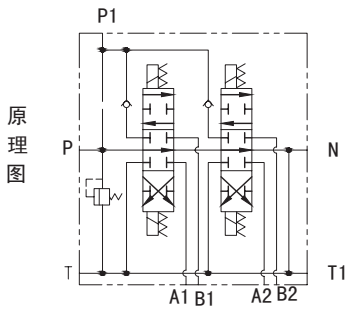
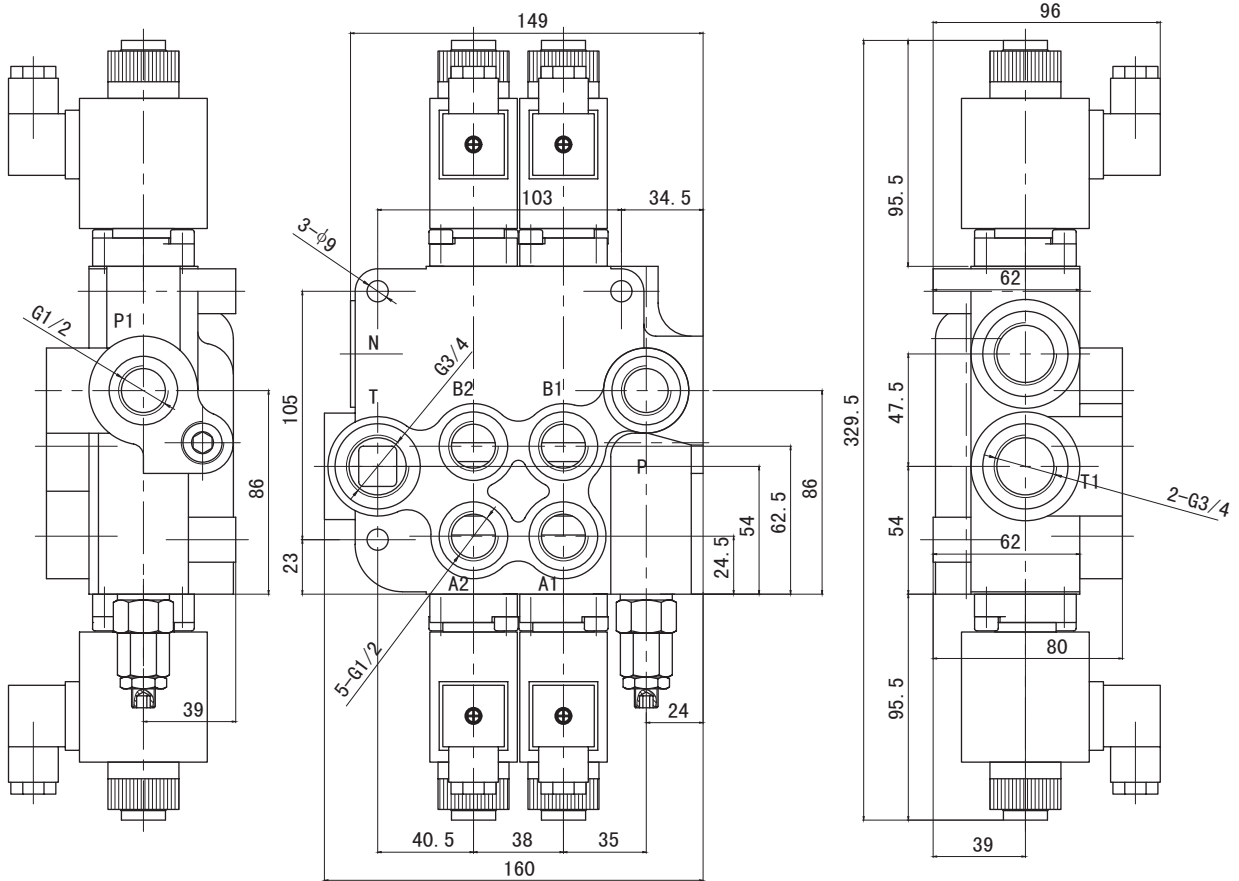

原理图

- 技术参数:
- 1. 公称压力 20MPa
  - 3. 额定流量 80L/min

注: 订货有特殊要求者, 请与销售顾问联系。  
 Note: Special features not listed can often be made to your specifications. Please consult your sales representative.

a10

P80系列电磁控整体阀 MDCV

# P80 系列电液控多路阀

## P80 Electric and Hydraulic Control Valve

### 用途与特征/APPLICATIONS&FEATURES

P80系列整体式多路阀是我公司引进欧洲的种中高压整体式多路阀。可按客户要求可在阀上设溢流阀、单向阀。溢流阀可调节压力，单向阀防止油液倒流。换向阀的滑阀机能可有A,O,P,Y等，可任意组合，换向手柄有两种安装形式，便于不同方向的操作，该阀采用并联或者串联油路，设计有压力输出口与其他液压元件相连接提供动力源。经过特殊设计的密封方式，使阀的密封性能卓越。该阀广泛应用于叉车、环卫车辆、小型装载机等工程机械的液压系统。

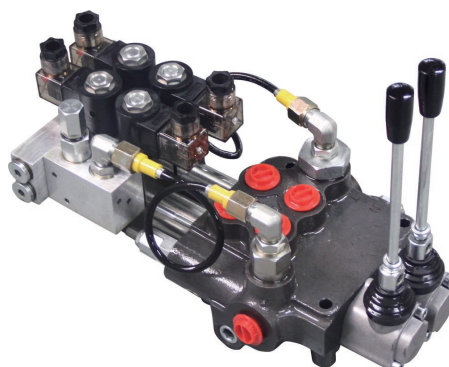

P80 series valves with middle-high pressure monoblock construction is developed based on Europe technology.

- ◆ Inner check valve: The check valve inside the valve body is to insure the hydraulic oil will not be returned.
- ◆ Inner relief valve: The relief valve inside the valve body is able to adjust the hydraulic system working pressure.
- ◆ Oil way: Parallel circuit, power beyond option
- ◆ Control Way: Manual control, pneumatic control, hydraulic and electric control for optional.
- ◆ Valve construction: monoblock construction, 1-6 levers.
- ◆ Spool Function: O,Y,P,A.
- ◆ Option: Hydraulic lock is available to be added on A and B port.
- ◆ Available with manual, pneumatic control, electric and pneumatic control, hydraulic and electric control and etc.

### 型号说明/MODEL CODE

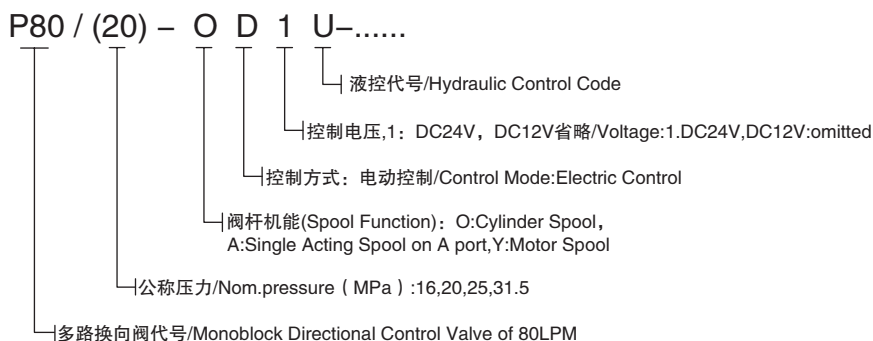

### 技术参数/PARAMETERS

公称压力 (MPa) Nom. Pressure	最大压力 (MPa) Max. Pressure	公称流量 (L/min) Nom. Flow rate	最大流量 (L/min) Max. Flow rate	中位背压 (MPa) Back Pressure	工作油液hydraulic oil		
					温度范围 (℃) Tem.rang	粘度范围 (mm <sup>2</sup> /S) Visc.rang	过滤精度 (μm) filtrating accuracy
20	31.5	80	80	≤1	-20 ~ +80	10 ~ 400	≤10

a11

P80系列电液控多路阀 MDCV

# P80 系列电液控多路阀

## P80 Electric and Hydraulic Control Valve

### 油口尺寸/PORT SIZE

油口 MAIN PORTS	英制 BSP	美制 UN-UNF	公制 METRIC
进油口 Inlet P	G1/2	7/8-14UNF	M22 × 1.5
工作油口 Ports A and B	G1/2	7/8-14UNF	M22 × 1.5
出油口 Outlet T	G3/4	1 1/16-14UNF	M26 × 1.5
高压输出口 carry-over C	G3/4	1 1/16-14UNF	M26 × 1.5

注：订货有特殊要求者，请与销售顾问联系。

Note: Special features not listed can often be made to your specifications. Please consult your sales representative.

### P80外形安装连接尺寸/MODEL P80 DIMENSIONAL DATA

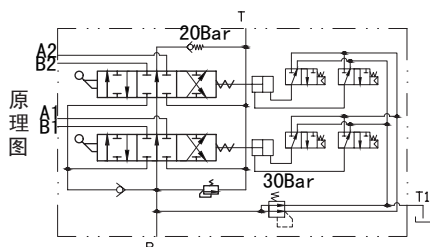
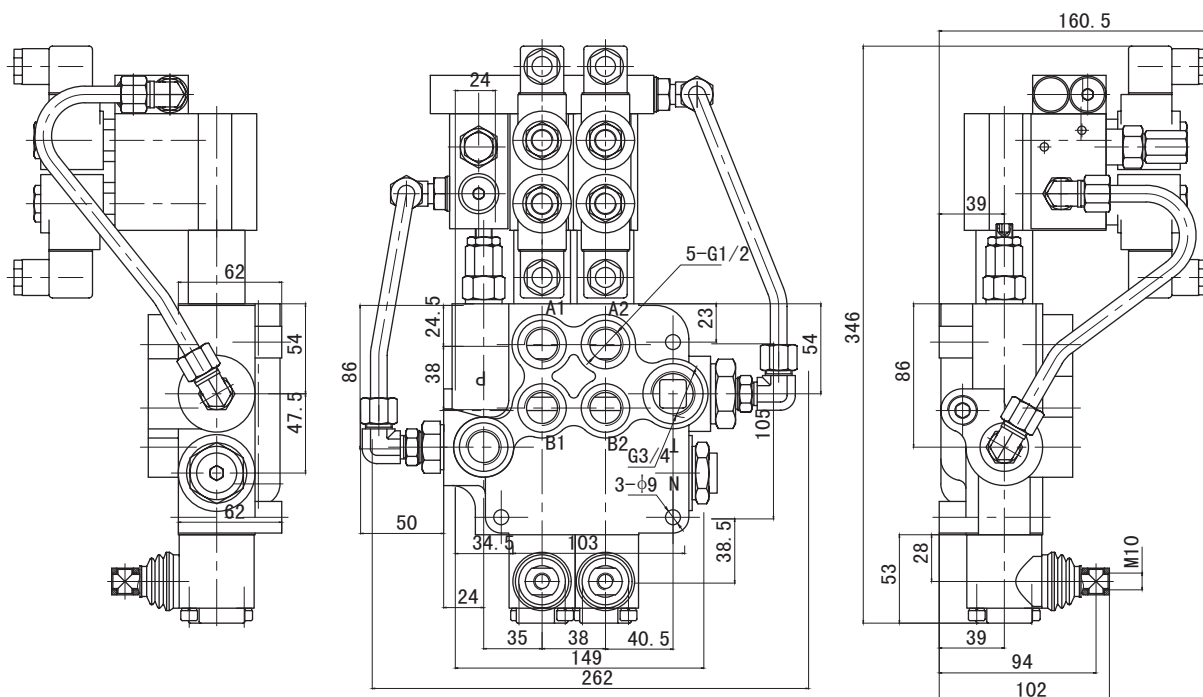

技术参数:

1. 公称压力 20MPa
2. 额定流量 80L/min
3. 控制电压为直流 DC12V/DC24V。

# RD5000系列整体式多路阀

## RD5000 Series Monoblock Directional Control Valves

### 用途与特征/APPLICATIONS&FEATURES

RD5000系列整体式多路阀是我公司引进北美的一种中高压整体式多路阀。可按客户要求，在阀上设溢流阀、单向阀。溢流阀可调节压力，单向阀防止油液倒流。换向阀的滑阀机能可有A,O,P,Y等，可任意组合，换向手柄有两种安装形式，便于不同方向的操作，该阀采用并联或者串联油路，设计有压力出口与其他液压元件相连接提供动力源。经过特殊设计的密封方式，使阀的密封性能卓越。该阀广泛应用于叉车、环卫车辆、小型装载机工程机械的液压系统。

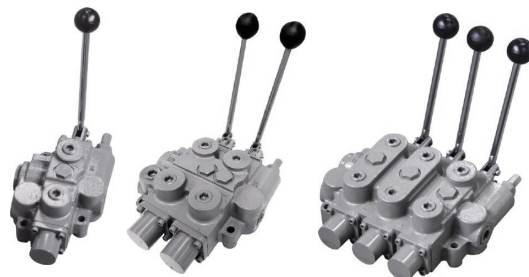

RD5000 series valves with middle-high pressure monoblock construction is developed based on North America technology.

◆ Inner check valve: The check valve inside the valve body is to insure the hydraulic oil will not be returned.

◆ Inner relief valve: The relief valve inside the valve body is able to adjust the hydraulic system working pressure.

◆ Oil way: Parallel circuit, power beyond option

◆ Control Way: Manual control, pneumatic control, hydraulic and electric control for optional.

◆ Valve construction: monoblock construction, 1-3 levers.

◆ Spool Function: O,Y, P,A.

◆ Option: Hydraulic lock is available to be added on A and B port.

◆ Available manual, pneumatic control, electric and pneumatic control, hydraulic and electric control and etc.

### 型号说明/MODEL CODE

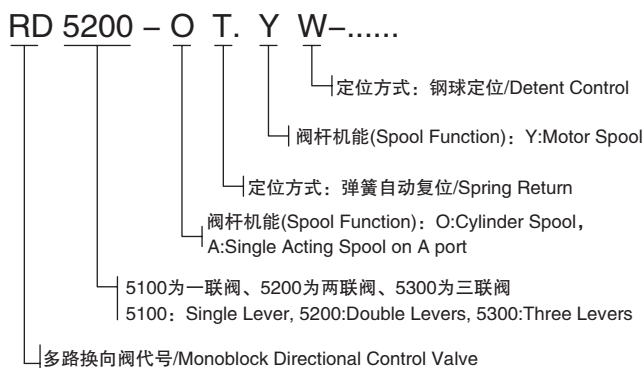

### 技术参数/PARAMETERS

公称压力 (MPa) Nom. Pressure	最大压力 (MPa) Max. Pressure	公称流量 (L/min) Nom. Flow rate	最大流量 (L/min) Max. Flow rate	中位背压 (MPa) Back Pressure	工作油液hydraulic oil		
					温度范围 (°C) Tem.rang	粘度范围 (mm <sup>2</sup> /S) Visc.rang	过滤精度 (μm) filtrating accuracy
20	31.5	100	120	≤1	-20 ~ +80	10 ~ 400	≤10

# RD5000系列整体阀

## RD5000 Series Monoblock Directional Control Valves

### 油口尺寸/PORT SIZE

油口 MAIN PORTS	英制 BSP	美制 SAE	美制 NPT
进油口 Inlet P	G3/4	SAE12	NPT3/4
工作油口 Ports A and B	G3/4, G1/2	SAE12, SAE10	NPT3/4, NPT1/2
出油口 Outlet T	G3/4, G1/2	SAE12	NPT3/4, NPT1/2
高压输出口 carry-over C	G3/4	SAE12	NPT3/4

注：订货有特殊要求者，请与销售顾问联系。

Note: Special features not listed can often be made to your specifications. Please consult your sales representative.

### RD5200外形安装连接尺寸/MODEL RD5200 DIMENSIONAL DATA

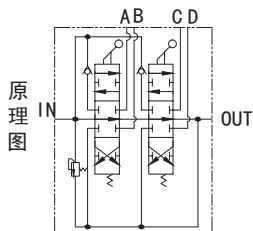
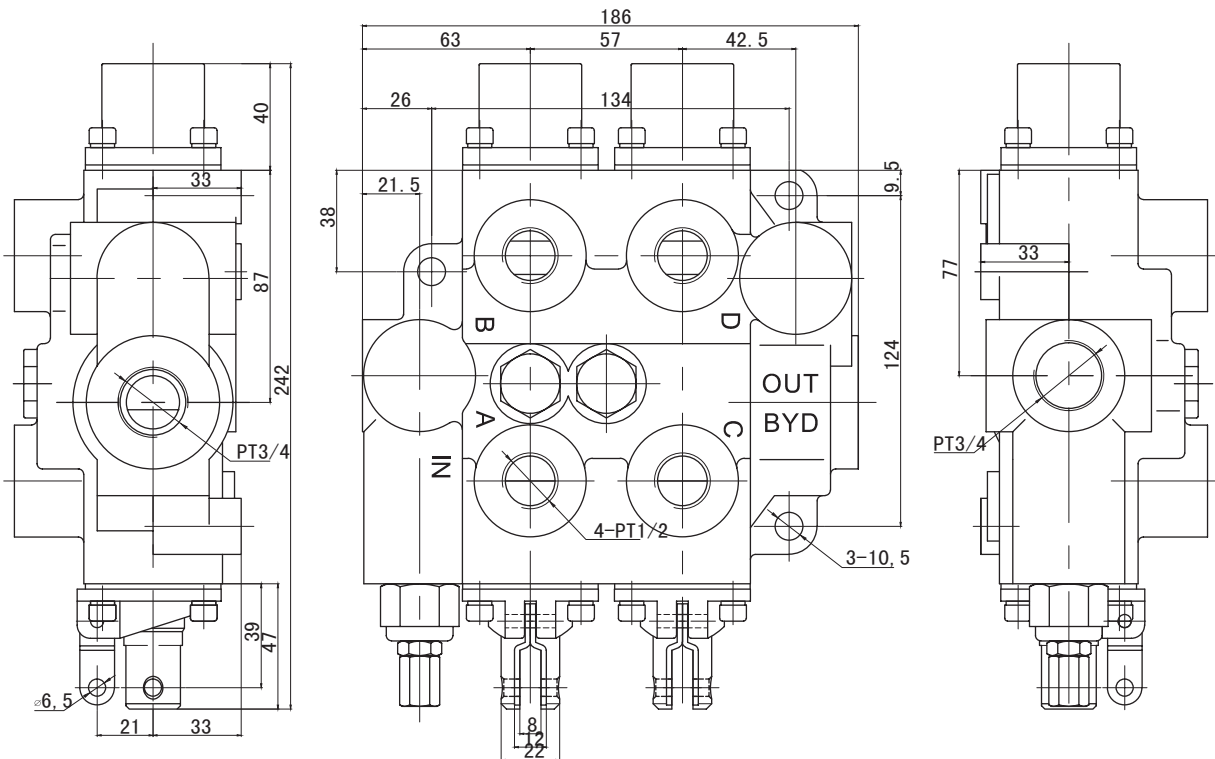

技术参数:

1. 公称压力 20MPa
2. 最大流量 120L/min

a14

RD5000系列整体阀MDCV

# RD5000系列整体阀

## RD5000 Series Monoblock Directional Control Valves

### RD5300外形安装连接尺寸/MODEL RD5300 DIMENSIONAL DATA

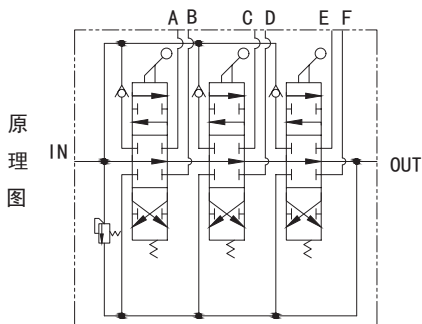
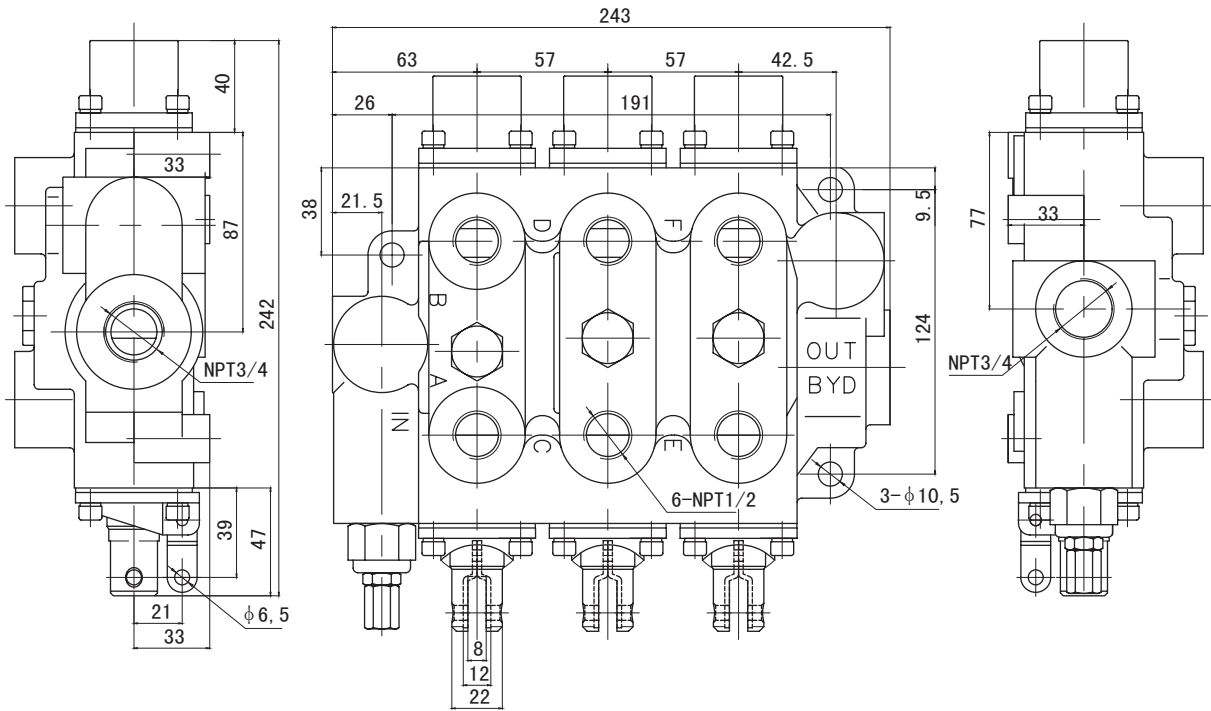

- 技术参数:
1. 公称压力 20MPa
  2. 最大流量 120L/min

a15

RD5000系列整体阀 MDCV

# HM2系列整体阀

## HM2 Series Monoblock Directional Control Valve

### 用途与特征/APPLICATIONS&FEATURES

HM2系列整体阀引进了欧洲先进技术，具有结构紧凑、流量45l/min、重量轻、耐高压。该阀采用并联油路，设计有压力输出口与其他液压元件相连接提供动力源。该阀广泛应用于工程机械、环卫机械、油田设备、矿山机械和其他机械的液压系统。



### 产品特点/FEATURES

Simple, compact designed, this valve is only one section for open center and closed center hydraulic systems.

- ◆ Fitted with a main pressure relief valve.
- ◆ Diameter 16 mm - 0.63 in interchangeable spools.
- ◆ Available manual and remote with flexible cables spool control kits.

### 型号说明/MODEL CODE



### 技术参数/PARAMETERS

公称压力 ( MPa ) Nom. Pressure	最大压力 ( MPa ) Max. Pressure	公称流量 ( L/min ) Nom. Flow rate	最大流量 ( L/min ) Max. Flow rate	中位背压 ( MPa ) Back Pressure	工作油液hydraulic oil		
					温度范围 ( °C ) Tem.rang	粘度范围 ( mm2/S ) Visc.rang	过滤精度 ( μ m ) filtrating accuracy
16	31.5	45	45	≤1	-20 ~ +80	10 ~ 400	≤10

# HM2系列整体阀

## HM2 Series Monoblock Directional Control Valve

### HM2外形安装连接尺寸/MODEL HM2 DIMENSIONAL DATA

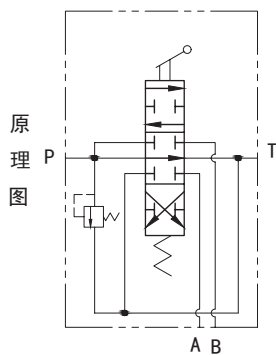
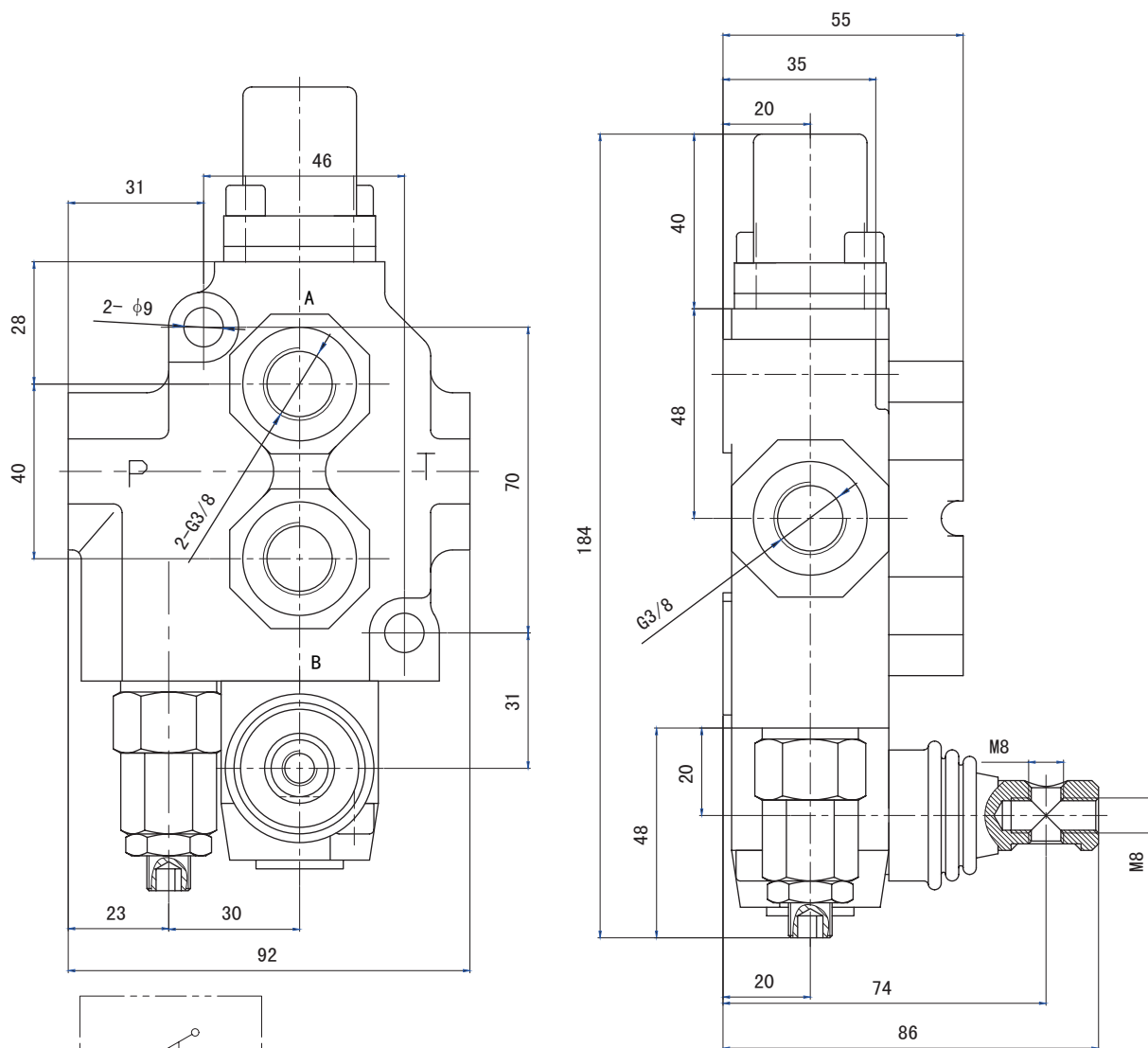

技术参数:

1. 公称压力 20MPa
3. 额定流量 45L/min

注: 订货有特殊要求者, 请与销售顾问联系。

Note: Special features not listed can often be made to your specifications. Please consult your sales representative.

# HM3 系列整体阀

## HM3 Series Monoblock Directional Control Valve

### 用途与特征/APPLICATIONS&FEATURES

HM3系列整体阀引进了欧洲先进技术，具有结构紧凑、流量45l/min、重量轻、耐高压。该阀采用并联油路，设计有压力输出口与其他液压元件相连接提供动力源。该阀广泛应用于工程机械、环卫机械、油田设备、矿山机械和其他机械的液压系统。



### 产品特点/FEATURES

Simple, compact and heavy duty designed monoblock valves from 1 to 6 sections for open and closed center hydraulic systems.

- ◆ Fitted with a main pressure relief valve and a load check valve.
- ◆ Available with parallel, series or tandem circuit.
- ◆ Optional power beyond port (only for parallel or tandem circuit).
- ◆ Diameter 16 mm - 0.63 in interchangeable spools.
- ◆ A wide variety of service port valve options.
- ◆ Actuation is manual, pneumatic, electro-pneumatic, hydraulic, electro-hydraulic, with solenoid and remote with flexible cables spool control kits.

### 型号说明/MODEL CODE

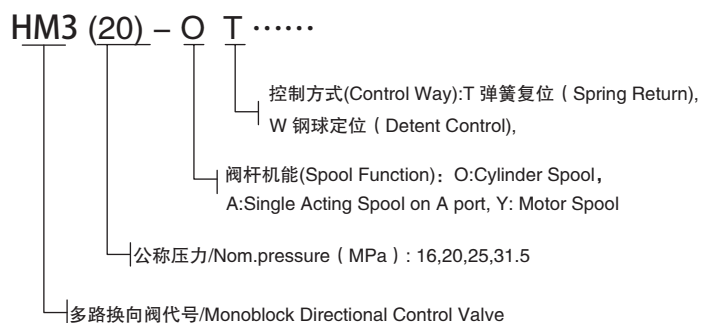

### 技术参数/PARAMETERS

公称压力 ( MPa ) Nom. Pressure	最大压力 ( MPa ) Max. Pressure	公称流量 ( L/min ) Nom. Flow rate	最大流量 ( L/min ) Max. Flow rate	中位背压 ( MPa ) Back Pressure	工作油液hydraulic oil		
					温度范围 ( °C ) Tem.rang	粘度范围 ( mm <sup>2</sup> /S ) Visc.rang	过滤精度 ( μm ) filtrating accuracy
20	31.5	45	45	≤1	-20 ~ +80	10 ~ 400	≤10

# HM3系列整体阀

## HM3 Series Monoblock Directional Control Valve

### 油口尺寸/PORT SIZE

油口 MAIN PORTS	英制 BSP	美制 UN-UNF	公制 METRIC
进油口 Inlet P	G3/8	3/4-16 (SAE 8)	M18 × 1.5
工作油口 Ports A and B	G3/8	9/16-18 (SAE 6)	M18 × 1.5
出油口 Outlet T	G3/8	3/4-16 (SAE 8)	M18 × 1.5, M22 × 1.5
高压输出口 carry-over C	M20 × 1.5	M20 × 1.5	M20 × 1.5

### HM3外形安装连接尺寸/MODEL HM3 DIMENSIONAL DATA

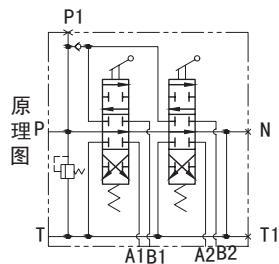
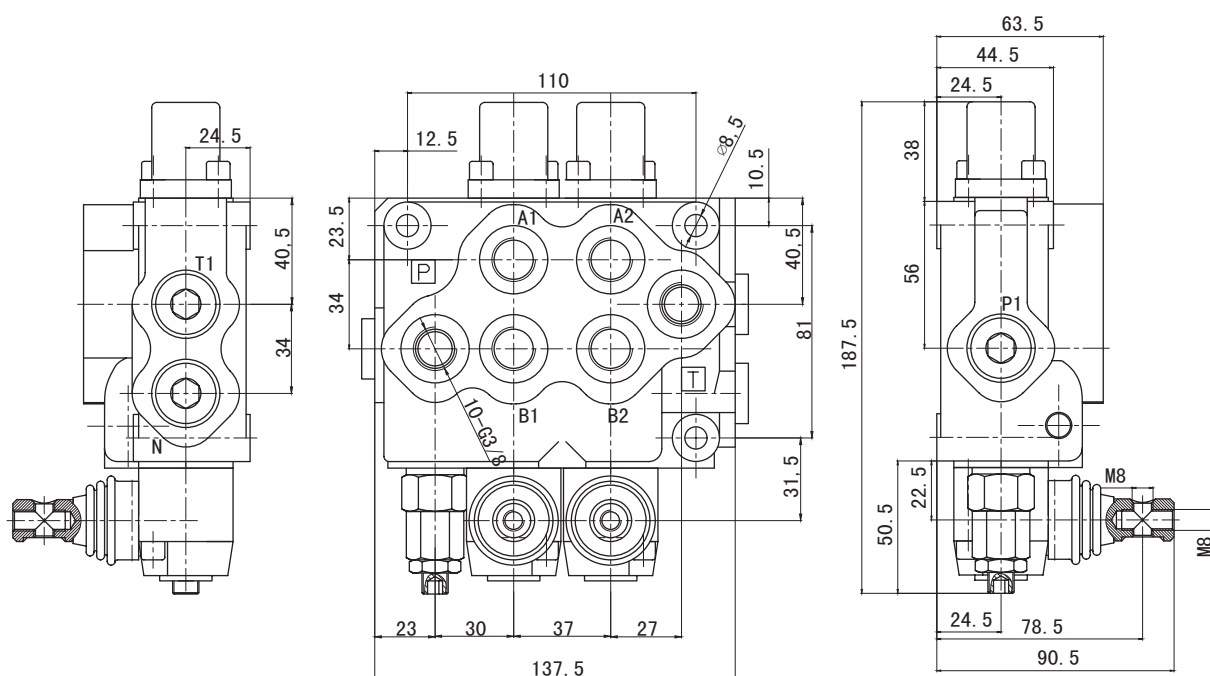

技术参数:  
 1. 公称压力 20MPa  
 3. 额定流量 45L/min

注: 订货有特殊要求者, 请与销售顾问联系。

Note: Special features not listed can often be made to your specifications. Please consult your sales representative.

# HM3系列电控整体阀

## HM3 Solenoid Control Valve

### 用途与特征/APPLICATIONS&FEATURES

HM3系列整体阀引进了欧洲先进技术，具有结构紧凑、流量45l/min、重量轻、耐高压。该阀采用并联油路，设计有压力输出口与其他液压元件相连接提供动力源。该阀广泛应用于工程机械、环卫机械、油田设备、矿山机械和其他机械的液压系统。

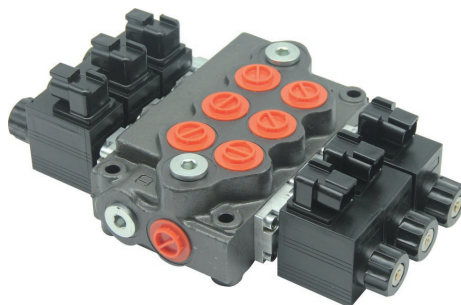

### 产品特点/FEATURES

Simple, compact and heavy duty designed monoblock valves from 1 to 6 sections for open and closed center hydraulic systems.

- ◆ Fitted with a main pressure relief valve and a load check valve.
- ◆ Available with parallel, series or tandem circuit.
- ◆ Optional power beyond port (only for parallel or tandem circuit).
- ◆ Diameter 16 mm - 0.63 in interchangeable spools.
- ◆ A wide variety of service port valve options.
- ◆ Actuation is manual, pneumatic, electro-pneumatic, hydraulic, electro-hydraulic, with solenoid and remote with flexible cables spool control kits.

### 型号说明/MODEL CODE

HM3 (20) - O D 1 .....



### 技术参数/PARAMETERS

公称压力 (MPa) Nom. Pressure	最大压力 (MPa) Max. Pressure	公称流量 (L/min) Nom. Flow rate	最大流量 (L/min) Max. Flow rate	中位背压 (MPa) Back Pressure	工作油液hydraulic oil		
					温度范围 (℃) Tem.rang	粘度范围 (mm <sup>2</sup> /S) Visc.rang	过滤精度 (μm) filtrating accuracy
20	31.5	45	45	≤1	-20 ~ +80	10 ~ 400	≤10

# HM3系列电控整体阀

## HM3 Solenoid Control Valve

### 油口尺寸/PORT SIZE

油口 MAIN PORTS	英制 BSP	美制 UN-UNF	公制 METRIC
进油口 Inlet P	G3/8	3/4-16 (SAE 8)	M18 × 1.5
工作油口 Ports A and B	G3/8	9/16-18 (SAE 6)	M18 × 1.5
出油口 Outlet T	G3/8	3/4-16 (SAE 8)	M18 × 1.5, M22 × 1.5
高压输出口 carry-over C	M20 × 1.5	M20 × 1.5	M20 × 1.5

注：订货有特殊要求者，请与销售顾问联系。

Note: Special features not listed can often be made to your specifications. Please consult your sales representative.

### HM3外形安装连接尺寸/MODEL HM3 DIMENSIONAL DATA

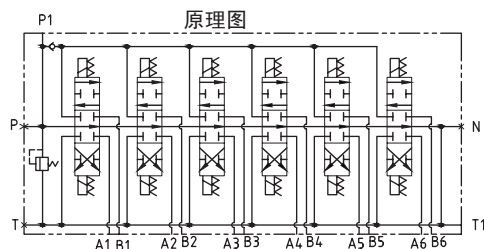
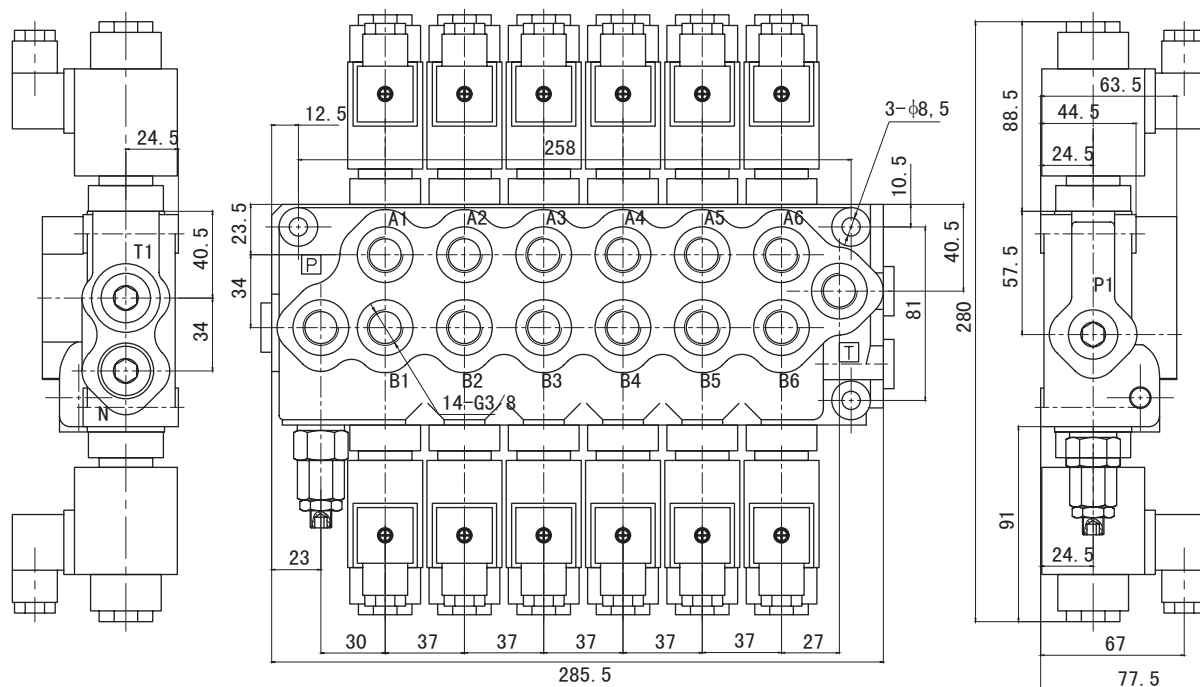

- 技术参数:
1. 公称压力 20MPa
  2. 最大流量 45L/min
  3. 额定电压 DC12V

a21

HM3系列电控整体阀 MDCV

# HM7系列整体阀

## HM7 Series Monoblock Directional Control Valve

### 用途与特征/APPLICATIONS&FEATURES

HM7系列整体阀引进了欧洲先进技术，具有结构紧凑、流量70L/min、重量轻、耐高压。该阀采用并联油路，设计有压力出口与其他液压元件相连接提供动力源。该阀广泛应用于工程机械、环卫机械、油田设备、矿山机械和其他机械的液压系统。



### 产品特点/FEATURES

Simple, compact and heavy duty designed monoblock valves from 1 to 6 sections for open and closed center hydraulic systems.

- ◆ Fitted with a main pressure relief valve and a load check valve.
- ◆ Available with parallel or series circuit.
- ◆ Optional power beyond port (only for parallel circuit).
- ◆ Diameter 20 mm - 0.79 in interchangeable spools.
- ◆ A wide variety of service ports and circuit valves.
- ◆ Available manual, pneumatic, hydraulic, electro-hydraulic and remote with flexible cables spool control kits.

### 型号说明/MODEL CODE

HM7 (20) - O T .....



### 技术参数/PARAMETERS

公称压力 ( MPa ) Nom. Pressure	最大压力 ( MPa ) Max. Pressure	公称流量 ( L/min ) Nom. Flow rate	最大流量 ( L/min ) Max. Flow rate	中位背压 ( MPa ) Back Pressure	工作油液hydraulic oil		
					温度范围 ( °C ) Tem.rang	粘度范围 ( mm <sup>2</sup> /S ) Visc.rang	过滤精度 ( μm ) filtrating accuracy
20	31.5	70	70	≤1	-20 ~ +80	10 ~ 400	≤10

# HM7系列整体阀

## HM7 Series Monoblock Directional Control Valve

### 油口尺寸/PORT SIZE

油口 MAIN PORTS	英制 BSP	美制 UN-UNF	公制 METRIC
进油口 Inlet P	G1/2	7/8-14 (SAE 10)	M22 × 1.5
工作油口 Ports A and B	G1/2	3/4-16 (SAE 8)	M22 × 1.5
出油口 Outlet T	G3/4	7/8-14 (SAE 10)	M27 × 2
高压输出口 carry-over C	M27 × 2	M27 × 2	M27 × 2

### HM7外形安装连接尺寸/MODEL HM7 DIMENSIONAL DATA

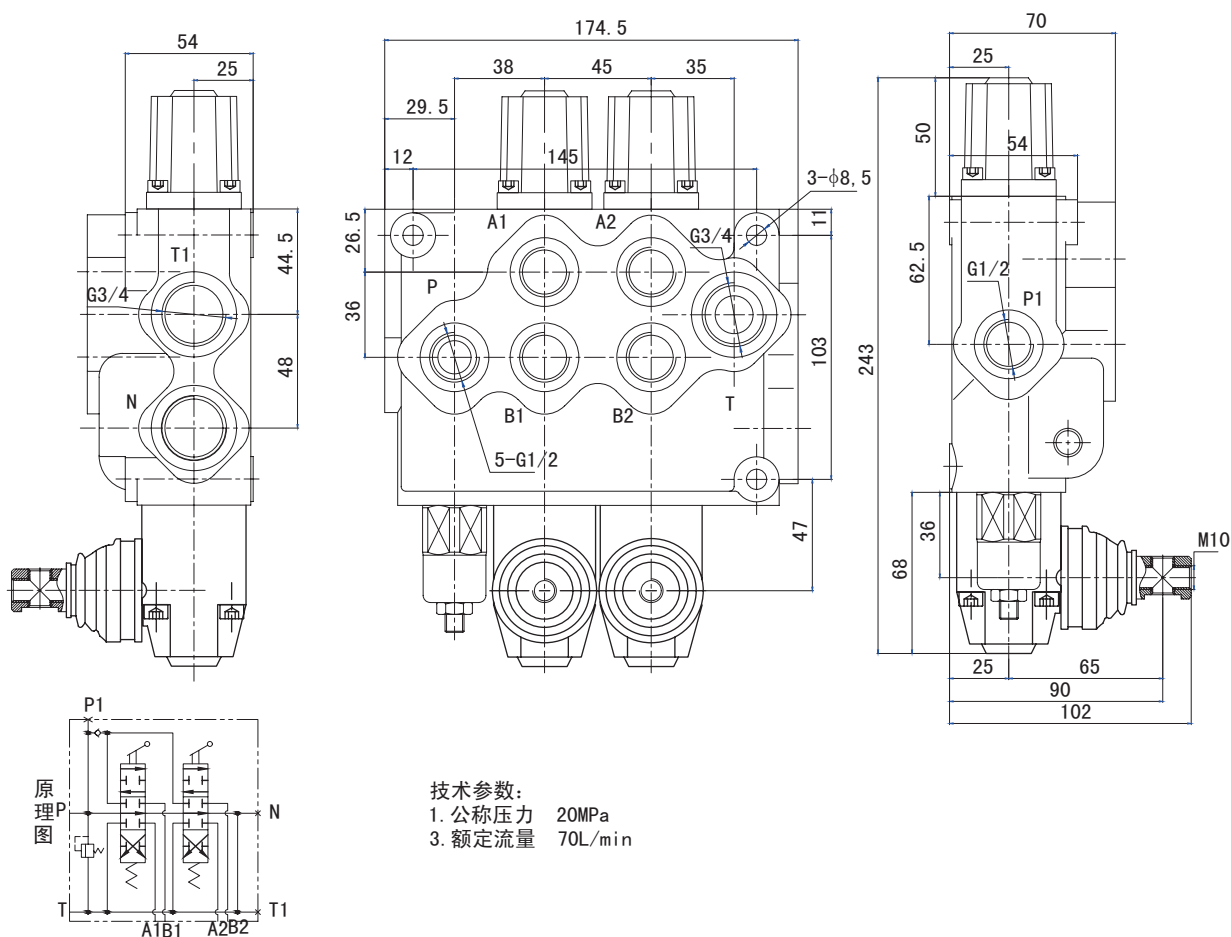

注: 订货有特殊要求者, 请与销售顾问联系。

Note: Special features not listed can often be made to your specifications. Please consult your sales representative.

# HM10系列整体阀

## HM10 Series Monoblock Directional Control Valve

### 产品描述/SPECIFICATION

HM10系列整体阀引进了欧洲先进技术，具有结构紧凑、流量高达120l/min、重量轻。该阀采用并联油路，设计有压力输出口与其他液压元件相连接提供动力源。该阀广泛应用于工程机械、环卫机械、矿山机械和其他机械的液压系统。



### 产品特点/FEATURES

- ◆ Simple, compact designed, this valves is only one section for open centre and closed centre hydraulic systems.
- ◆ Fitted with a main pressure relief valve.
- ◆ Diameter 20 mm -- 0.79 in interchangeable spools.
- ◆ Available manual, pneumatic, electro--hydraulic and remote with flexible cable spool control kits.

### 型号说明/MODEL CODE

HM10 (20) - O T .....



### 技术参数/PARAMETERS

公称压力 (MPa) Nom. Pressure	最大压力 (MPa) Max. Pressure	公称流量 (L/min) Nom. Flow rate	最大流量 (L/min) Max. Flow rate	中位背压 (MPa) Back Pressure	工作油液hydraulic oil		
					温度范围 (℃) Tem.rang	粘度范围 (mm <sup>2</sup> /S) Visc.rang	过滤精度 (μm) filtrating accuracy
20	25	120	120	≤1	-20 ~ +80	10 ~ 400	≤10

# HM10系列整体阀

## HM10 Series Monoblock Directional Control Valve

### HM10外形安装连接尺寸/MODEL HM10 DIMENSIONAL DATA

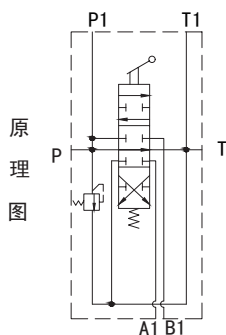
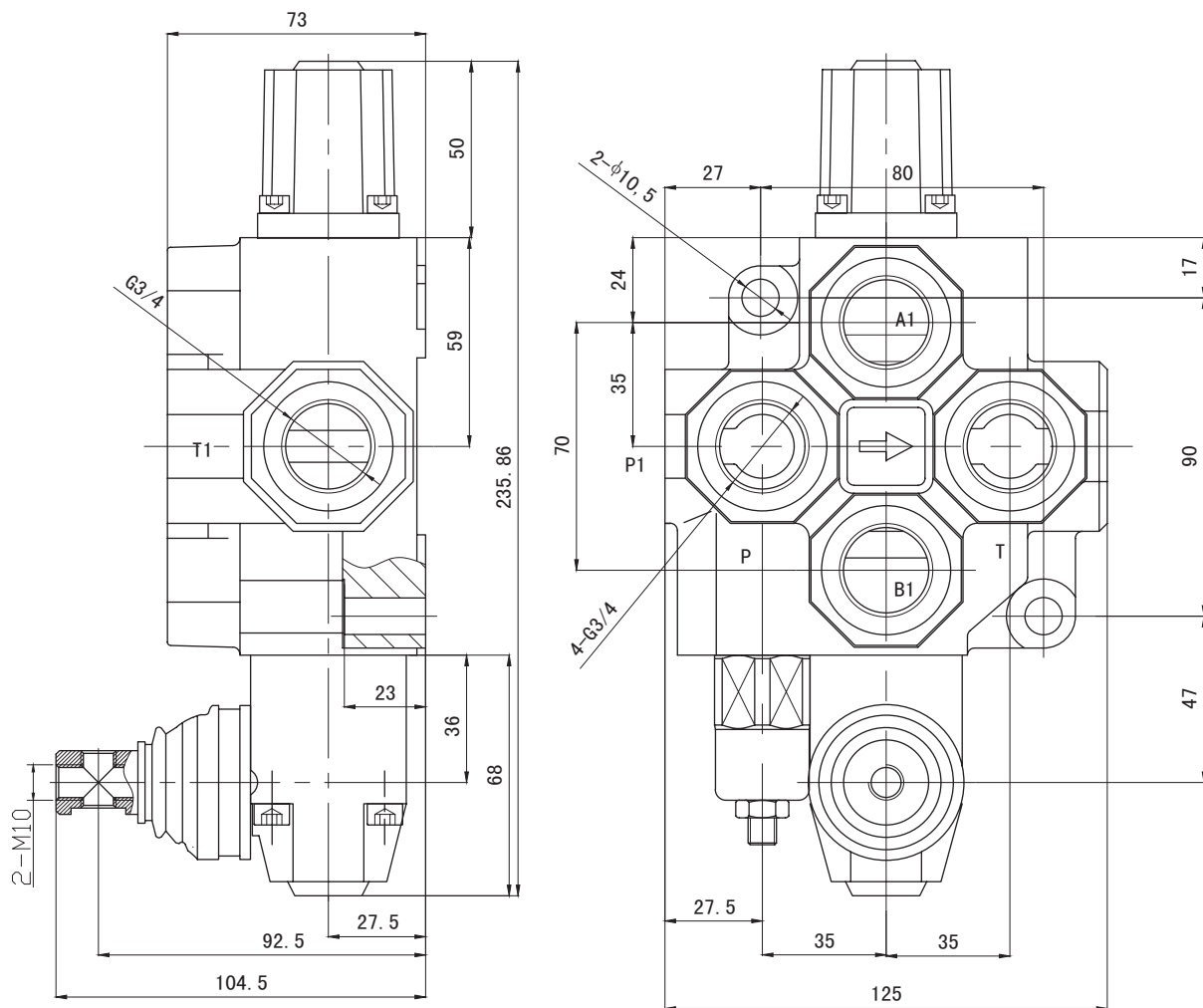

#### 主要技术参数:

1. 额定流量120L/min,
2. 公称压力20MPa.

注: 订货有特殊要求者, 请与销售顾问联系。

Note: Special features not listed can often be made to your specifications. Please consult your sales representative.

a25

HM10系列整体阀MDCV

# HM9滑移式装载机专用阀

## HM9 Series Monoblock Directional Control Valve

### 产品描述/SPECIFICATION

HM9系列整体阀引进了欧洲先进技术，采用了串联油路，每一片都配有一个单向阀，同时设计了压力输出口与其他液压元件相连接提供动力源。经过特殊设计的密封方式，使阀的密封性能卓越，可以代替进口阀，专门用于滑移式装载机。

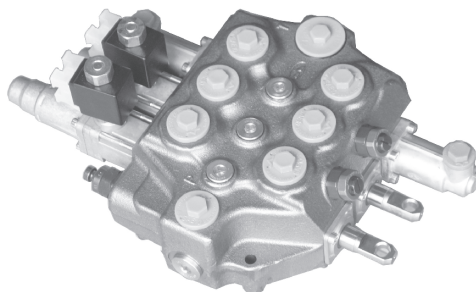

### 产品特点/FEATURES

- ◆ Simple, compact and heavy duty designed 3 sections monoblock valves for open centre hydraulic systems.
- ◆ Fitted with a main pressure relief valve.
- ◆ Each spool has independent load check valve.
- ◆ Series circuit.
- ◆ Optional carry--over port.
- ◆ A wide variety of service port valves.
- ◆ Available manual, electro--hydraulic and remote with flexible cables spool control kits.
- ◆ Diameter 18 mm -- 0.71 in interchangeable spools.

### 型号说明/MODEL CODE

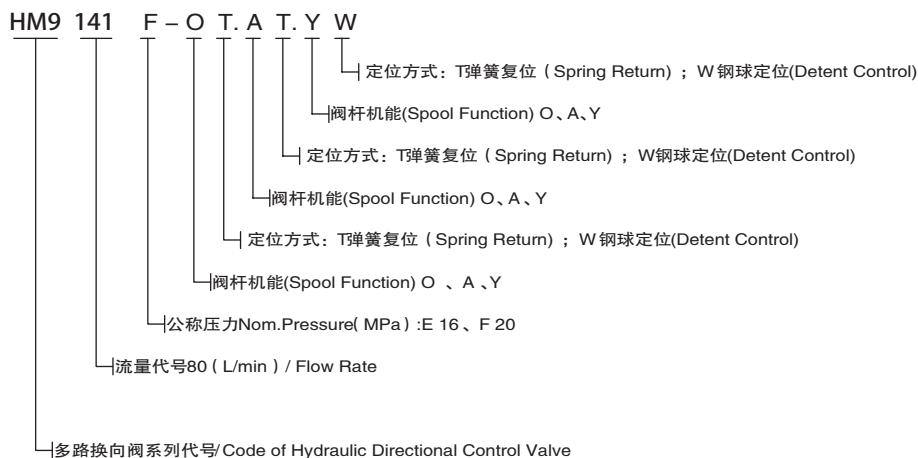

### 技术参数/PARAMETERS

公称压力 ( MPa ) Nom. Pressure	最大压力 ( MPa ) Max. Pressure	公称流量 ( L/min ) Nom. Flow rate	最大流量 ( L/min ) Max. Flow rate	中位背压 ( MPa ) Back Pressure	工作油液hydraulic oil		
					温度范围 ( °C ) Tem.rang	粘度范围 ( mm <sup>2</sup> /S ) Visc.rang	过滤精度 ( μ.m ) filtrating accuracy
20	25	80	90	≤1	-20 ~ +80	10 ~ 400	≤10

# HM9滑移式装载机专用阀

## HM9 Series Monoblock Directional Control Valve

### HM9外形安装连接尺寸/MODEL HM9 DIMENSIONAL DATA

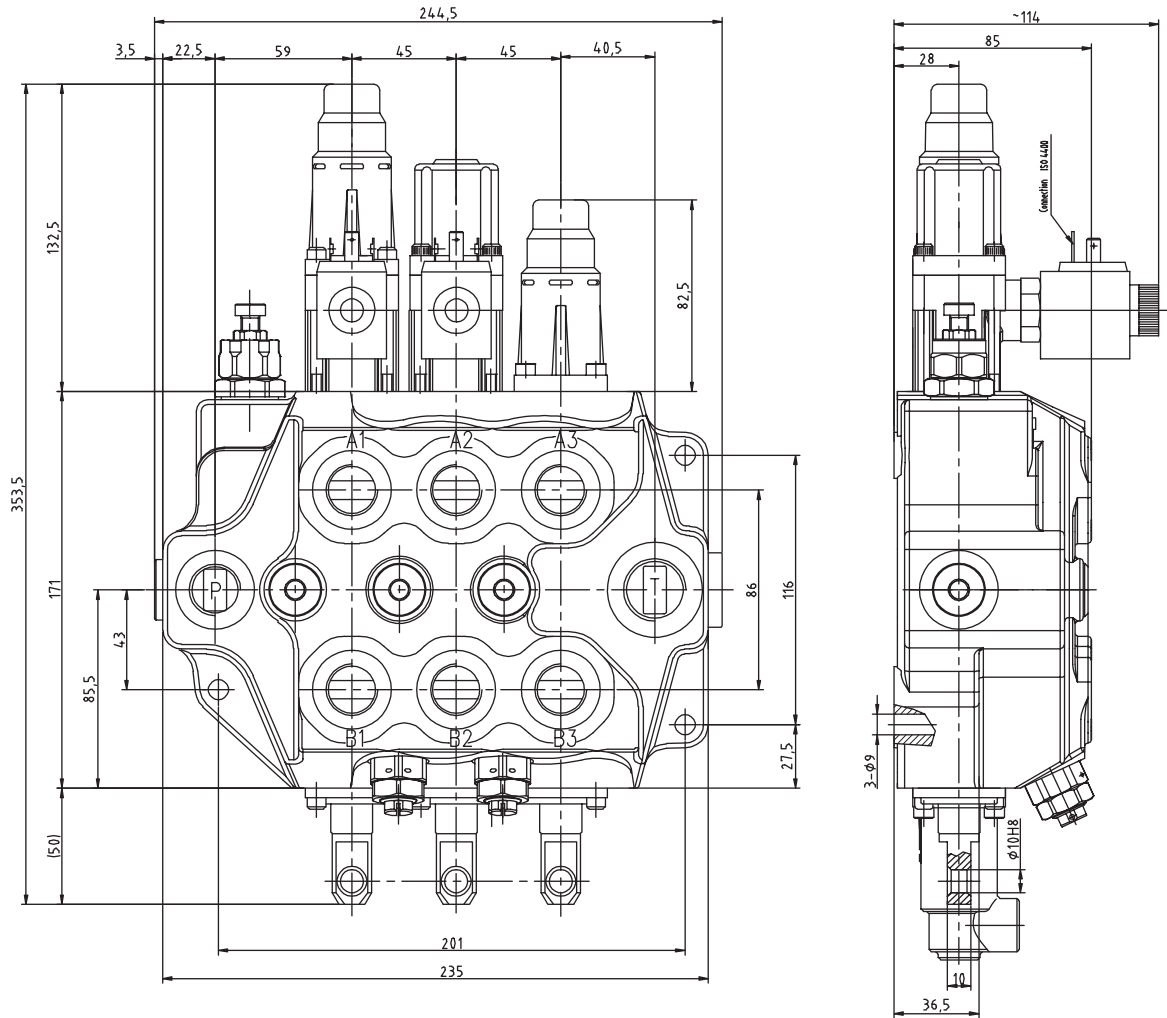

HYDRAULIC CIRCUIT

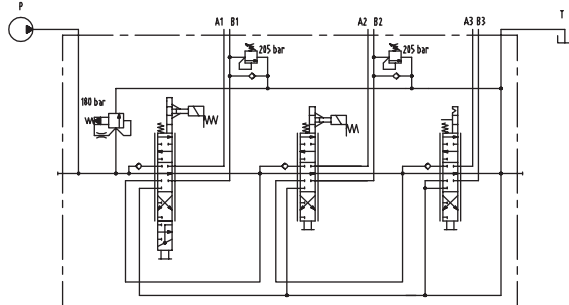

注：订货有特殊要求者，请与销售顾问联系。

Note: Special features not listed can often be made to your specifications. Please consult your sales representative.

# HM11系列整体阀

## HM11 Series Monoblock Directional Control Valve

### 用途与特征/APPLICATIONS&FEATURES

HM11系列整体阀引进了欧洲先进技术，具有结构紧凑、流量120L/min、重量轻、耐高压。该阀采用并联油路，设计有压力出口与其他液压元件相连接提供动力源。该阀广泛应用于工程机械、环卫机械、油田设备、矿山机械和其他机械的液压系统。



### 产品特点/FEATURES

Simple, compact and heavy duty designed monoblock from 1 to 4 sections for open and closed center hydraulic systems.

- ◆ Fitted with a direct or pilot operated main pressure relief valve.
- ◆ Parallel circuit.
- ◆ Optional carry-over port.
- ◆ Diameter 25 mm - 0.98 in interchangeable spools.
- ◆ A wide variety of service port valves.
- ◆ Available manual, pneumatic, electro-pneumatic, hydraulic and electro-hydraulic spool control kits.

### 型号说明/MODEL CODE

HM11 (20) - O T .....



### 技术参数/PARAMETERS

公称压力 ( MPa ) Nom. Pressure	最大压力 ( MPa ) Max. Pressure	公称流量 ( L/min ) Nom. Flow rate	最大流量 ( L/min ) Max. Flow rate	中位背压 ( MPa ) Back Pressure	工作油液hydraulic oil		
					温度范围 ( °C ) Tem.rang	粘度范围 ( mm <sup>2</sup> /S ) Visc.rang	过滤精度 ( μ m ) filtrating accuracy
20	31.5	120	160	≤1	-20 ~ +80	10 ~ 400	≤10

# HM11系列整体阀

## HM11 Series Monoblock Directional Control Valve

### 油口尺寸/PORT SIZE

油口 MAIN PORTS	英制 BSP	美制 UN-UNF
进油口 Inlet P	G3/4, G1	1 5/16-12 UN-2B (SAE 16)
工作油口 Ports A and B	G3/4, G1	1 1/16-12 UN-2B (SAE 12)
出油口 Outlet T	G1	1 5/16-12 UN-2B (SAE 16)
高压输出口 carry-over C	M36 × 1.5	M36 × 1.5

### HM11外形安装连接尺寸/MODEL HM11 DIMENSIONAL DATA

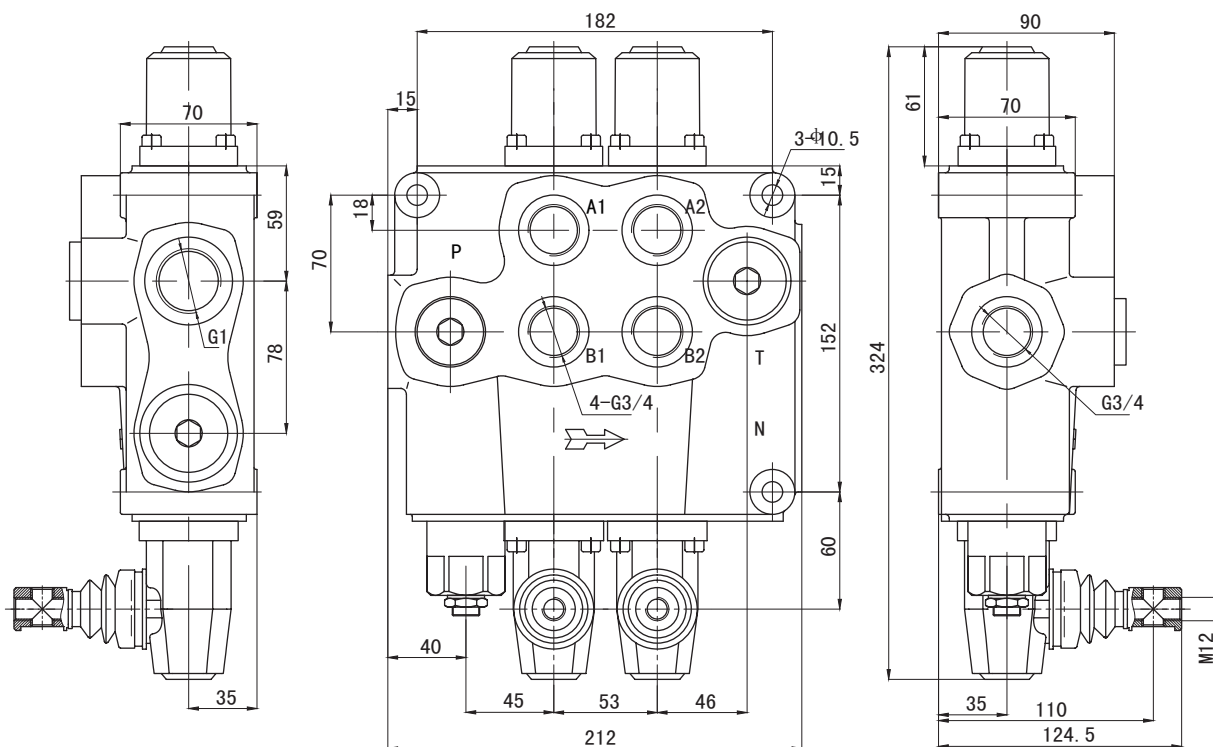

原理图

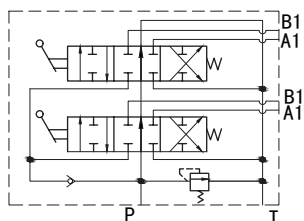

主要技术参数:

1. 最大流量160L/min,
  2. 公称压力20MPa.
- 最高压力31MPa

注: 订货有特殊要求者, 请与销售顾问联系。

Note: Special features not listed can often be made to your specifications. Please consult your sales representative.

# DCV20系列整体阀

## DCV20 Series Monoblock Directional Control Valves.

### 用途与特征/APPLICATIONS&FEATURES

DCV20多路换向阀是我单位自主设计开发的一种中高压整体式多路换向阀。可按客户要求，在阀上设溢流阀等。溢流阀可调节系统压力，单向阀防止油液倒流，换向阀滑阀机能可有A、O、Y、P等，可任意组合。换向手柄有两种安装形式，便于不同方向的操作。该阀采用并联油路，经过特殊设计的密封方式，使该阀的密封性能卓越。该阀广泛用于叉车、环卫车辆、小型装载机工程机械的液压系统。

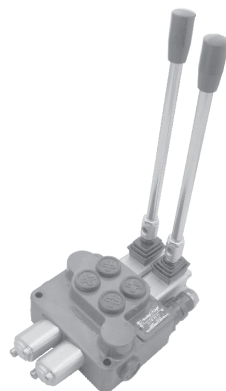

Model DCV20 with middle-high pressure monoblock and 1-6 spools construction is an independently developed control valves by our company.

- ◆ Inner check valve: The check valve inside the valve body is to insure the hydraulic oil not to be returned.
- ◆ Inner relief valve: The relief valve inside the valve body is able to adjust the hydraulic system working pressure.
- ◆ Oil way: Parallel circuit,
- ◆ Control Way: Manual control
- ◆ Valve construction: monoblock construction, 2levers.
- ◆ Spool Function: O,A,Y P.

### 性能参数/SPECIFICATIONS

公称压力 Nominal Pressure ( Mpa )	最大压力 Max. pressure ( Mpa )	公称流量 Nom. flow ( L/min )	允许背压 Allowable Back. pressure ( Mpa )	工作油液 Hydraulic Oil		
				温度范围 Tem.range ( °C )	粘度范围 Visc.range ( mm2/s )	过滤精度 Filtrating accuracy ( μm )
16	31.5	20	≤ 1	-20~+80	10~400	≤ 10

注：油液最高污染等级：按GB/T14039之19/16

Note: maximum permissible degree of contamination of the oil is according to GB/T14039-19/16

### 型号说明/MODEL CODE

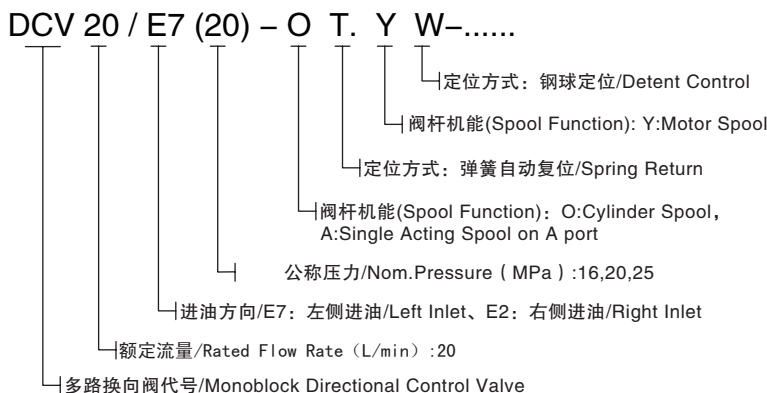

注：订货有特殊要求者，请与销售顾问联系。

Note: Specifical features not listed on can often be made to your specifications. Please consult your sales representative.

# DCV20系列整体阀

## DCV20 Series Monoblock Directional Control Valves.

### DCV20外形安装连接尺寸/MODEL DCV20 DIMENSIONAL DATA

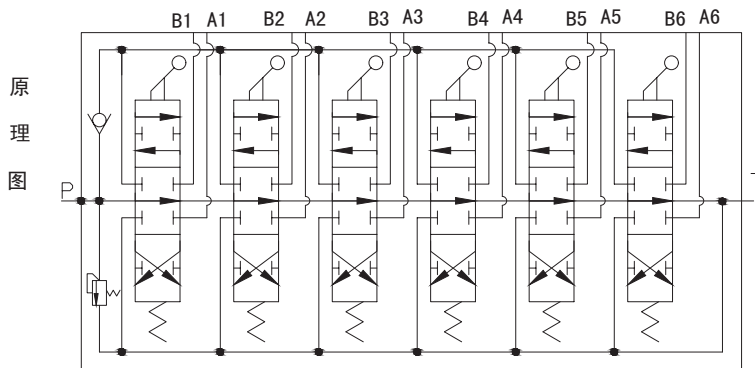
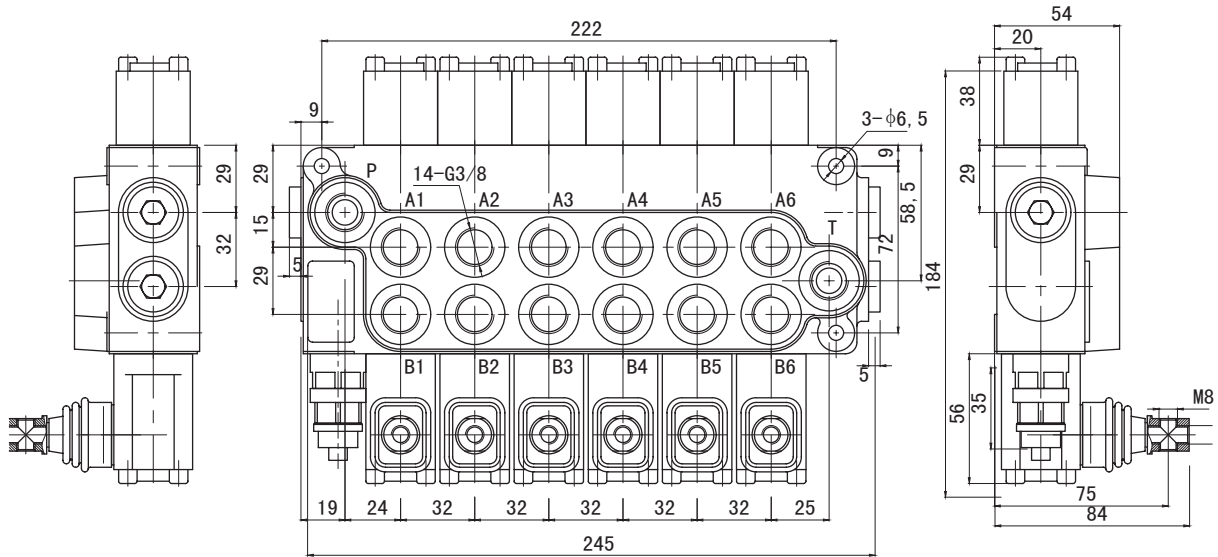

技术参数:

1. 公称压力 20MPa
2. 额定流量 20L/min

a31

DCV20系列整体阀 MDCV

# DCV40系列整体阀

## DCV40 Series Monoblock Directional Control Valves.

### 用途与特征/APPLICATIONS&FEATURES

DCV40多路换向阀是我单位自主设计开发的一种中高压整体式多路换向阀。可按客户要求可在阀上设溢流阀、液压锁、单向阀等。溢流阀可调节系统压力，单向阀防止油液倒流，换向阀滑阀机能可有A、O、Y、P等，可任意组合，换向手柄有两种安装形式，便于不同方向的操作，该阀采用并联油路，设计有压力输出口与其它液压元件相接提供动力源。经过特殊设计的密封方式，使阀的密封性能卓越。该阀广泛用于叉车、环卫车辆、小型装载机等工程机械的液压系统。



Model DCV40 with middle-high pressure monoblock construction is an independently developed control valves by our company.

- ◆ Inner check valve: The check valve inside the valve body is to insure the hydraulic oil not to be returned.
- ◆ Inner relief valve: The relief valve inside the valve body is able to adjust the hydraulic system working pressure.
- ◆ Oil way: Parallel circuit, power beyond option
- ◆ Control Way: Manual control, pneumatic control, hydraulic and electric control for optional.
- ◆ Valve construction: monoblock construction, 1-8 levers.
- ◆ Spool Function: O, Y, P, A.
- ◆ Option: Hydraulic lock is available to be added on A and B port.
- ◆ The valve is widely used in the hydraulic system of forklift, environment vehicle and light loading machines.

### 性能参数/SPECIFICATIONS

公称压力 Nominal Pressure ( Mpa )	最大压力 Max. pressure ( Mpa )	公称流量 Nom. flow ( L/min )	允许背压 Allowable Back. pressure ( Mpa )	工作油液 Hydraulic Oil		
				温度范围 Tem.range ( °C )	粘度范围 Visc.range ( mm <sup>2</sup> /s )	过滤精度 Filtrating accuracy ( μm )
16	31.5	50	≤1	-20~+80	10~400	≤10

注：油液最高污染等级：按GB/T14039之19/16

Note: maximum permissible degree of contamination of the oil is according to GB/T14039-19/16

# DCV40系列整体阀

## DCV40 Series Monoblock Directional Control Valves.

### 型号说明/MODEL CODE

DCV 40 / E7 (20) - O T. Y W-.....

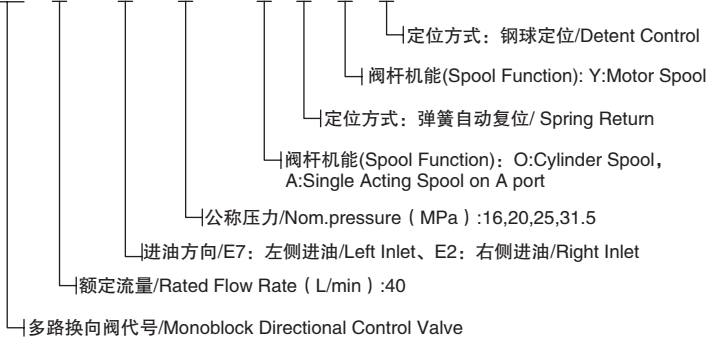

注: 订货有特殊要求者, 请与销售顾问联系。

Note: Special features not listed can often be made to your specifications. Please consult your sales representative.

### DCV40外形安装连接尺寸/MODEL DCV40 DIMENSIONAL DATA

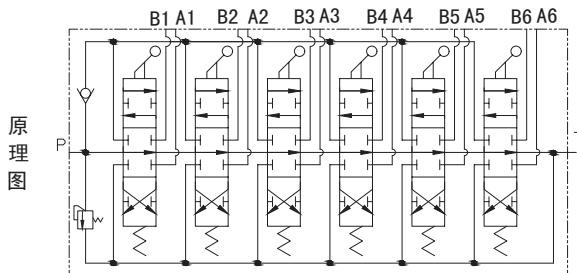
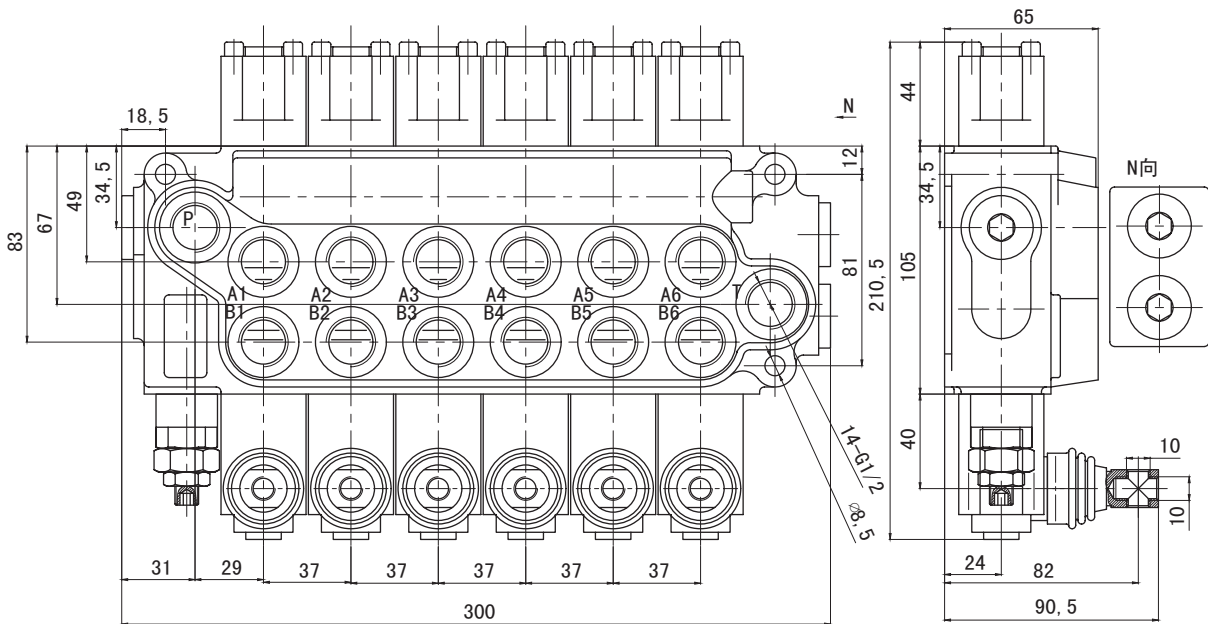

技术参数:

1. 公称通径 12mm
2. 公称压力 20MPa
3. 最大流量 50L/min

# DCV40气控系列多路阀

## DCV40 Pneumatic Control Valve Series

### 产品描述/SPECIFICATION

DCV40气控系列多路阀是在DCV40手动控制系列的基础上改进而来。它主要是改变了手动换向阀的操纵机构，在手动的基础上增加了气动控制，能够更好地实现远程控制。DCV40系列多路阀的回油端设置了压力输出口，可与其他液压元件串联使用。根据用户需要，换向阀的操纵机构可以和普通手动控制进行任意组合。该阀广泛应用于工程机械、环卫机械、矿山机械和其他机械的液压系统。



### 产品特点/FEATURES

- ◆ 内置单向阀：阀体内置单向阀，防止油液倒流
- ◆ 内置安全阀：阀体内置溢流阀，可调节控制系统压力
- ◆ 油路形式：并联油路，带压力输出口
- ◆ 控制方式：气控换向，也可手动换向
- ◆ 阀体结构：整体结构，1-8联任意组合
- ◆ 阀杆机能：O、A、Y等
- ◆ Inner check valve: The check valve inside the valve body to insure the hydraulic oil not to be returned.
- ◆ Inner relief valve: The relief valve inside the valve body is able to adjust the hydraulic system working pressure.
- ◆ Oil way: Parallel circuit, with power beyond.
- ◆ Control Way: pneumatic control, manual control
- ◆ Valve construction: monoblock construction, 1-8 levers are available to assembled as you requests.
- ◆ Spool Function: O,A,Y etc.

### 型号说明/MODEL CODE

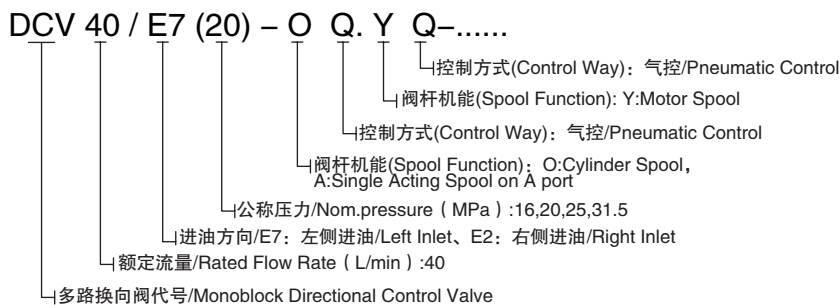

### 技术参数/PARAMETERS

公称压力 (MPa) Nom. Pressure	最大压力 (MPa) Max. Pressure	公称流量 (L/min) Nom. Flow rate	最大流量 (L/min) Max. Flow rate	中位背压 (MPa) Back Pressure	工作油液hydraulic oil		
					温度范围(℃) Tem.rang	粘度范围 (mm <sup>2</sup> /S) Visc.rang	过滤精度 (μm) filtrating accuracy
20	31.5	40	50	≤1	-20 ~ +80	10 ~ 400	≤10

# DCV40气控系列多路阀

## DCV40 Pneumatic Control Valve Series

### DCV40外形安装连接尺寸/MODEL DCV40 DIMENSIONAL DATA

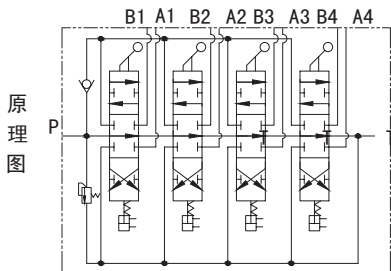
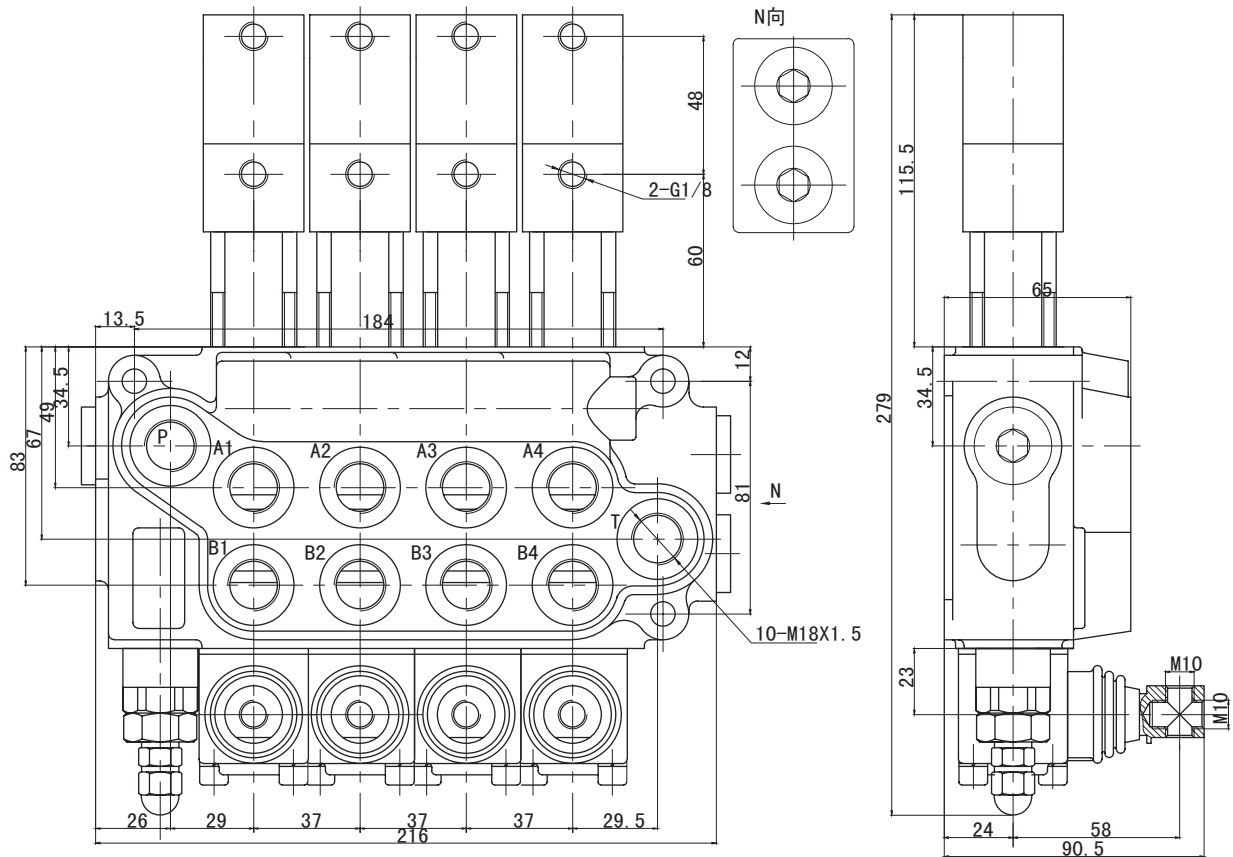

#### 技术参数:

1. 公称通径 12mm
2. 公称压力 20MPa
3. 最大流量 50L/min
4. 工作气压 8Kg

注: 订货有特殊要求者, 请与销售顾问联系。

Note: Special features not listed can often be made to your specifications. Please consult your sales representative.

a35

DCV40气控系列多路阀 MDCV

# DCV40电气控系列多路阀

## DCV40 Electric and Pneumatic Control Valve

### 产品描述/SPECIFICATION

DCV40电气控系列多路阀是在DCV40气控系列的基础上改进而来。它主要是改变了气控换向阀的操纵机构，在气控的基础上增加了电气控制，并且可以根据客户需求，安装无线遥控，能够更好地实现远程控制。该阀广泛应用于工程机械、环卫机械、矿山机械和其他机械的液压系统。

### 产品特点/FEATURES

- ◆ 内置单向阀：阀体内置单向阀，防止油液倒流
- ◆ 内置安全阀：阀体内置溢流阀，可调节控制系统压力
- ◆ 油路形式：并联油路，带压力输出口
- ◆ 控制方式：气控换向，也可手动换向
- ◆ 阀体结构：整体结构，1-8联任意组合
- ◆ 阀杆机能：O、A、Y等
- ◆ Inner check valve: The check valve inside the valve body to insure the hydraulic oil not to be returned.
- ◆ Inner relief valve: The relief valve inside the valve body is able to adjust the hydraulic system working pressure.
- ◆ Oil way: Parallel circuit, with power beyond.
- ◆ Control Way: electric and pneumatic control, manual control
- ◆ Valve construction: monoblock construction, 1-8 levers are available to be assembled as you requests.
- ◆ Spool Function: O,A,Y etc.

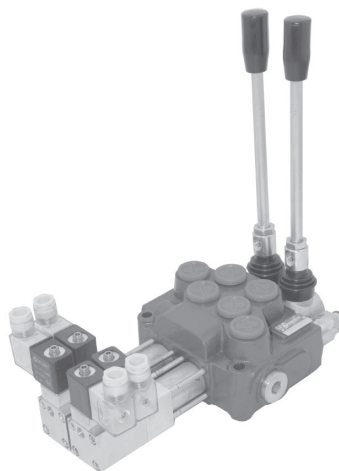

### 型号说明/MODEL CODE

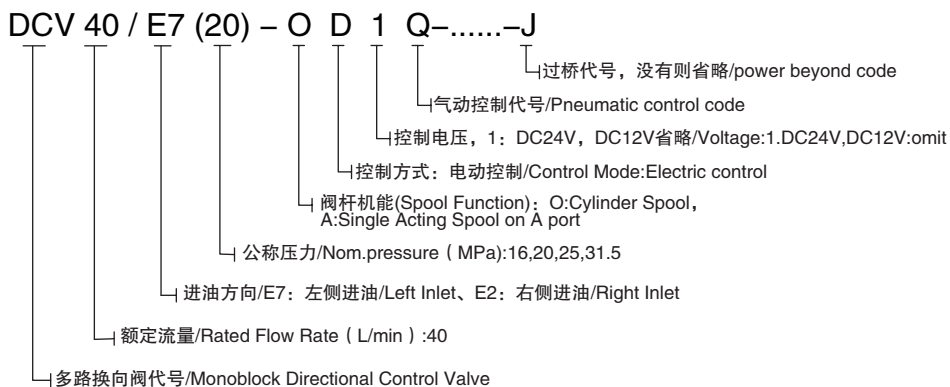

### 技术参数/PARAMETERS

公称压力 (MPa) Nom. Pressure	最大压力 (MPa) Max. Pressure	公称流量 (L/min) Nom. Flow rate	最大流量 (L/min) Max. Flow rate	中位背压 (MPa) Back Pressure	工作油液hydraulic oil		
					温度范围 (℃) Tem.rang	粘度范围 (mm <sup>2</sup> /S) Visc.rang	过滤精度 (μm) filtrating accuracy
20	31.5	40	50	≤1	-20 ~ +80	10 ~ 400	≤10

# DCV40电气控系列多路阀

## DCV40 Electric and Pneumatic Control Valve

### DCV40外形安装连接尺寸/MODEL DCV40 DIMENSIONAL DATA

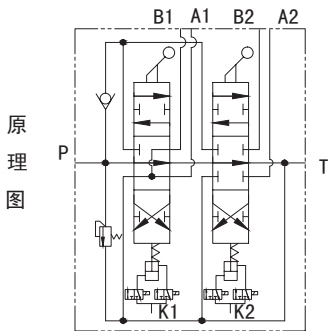
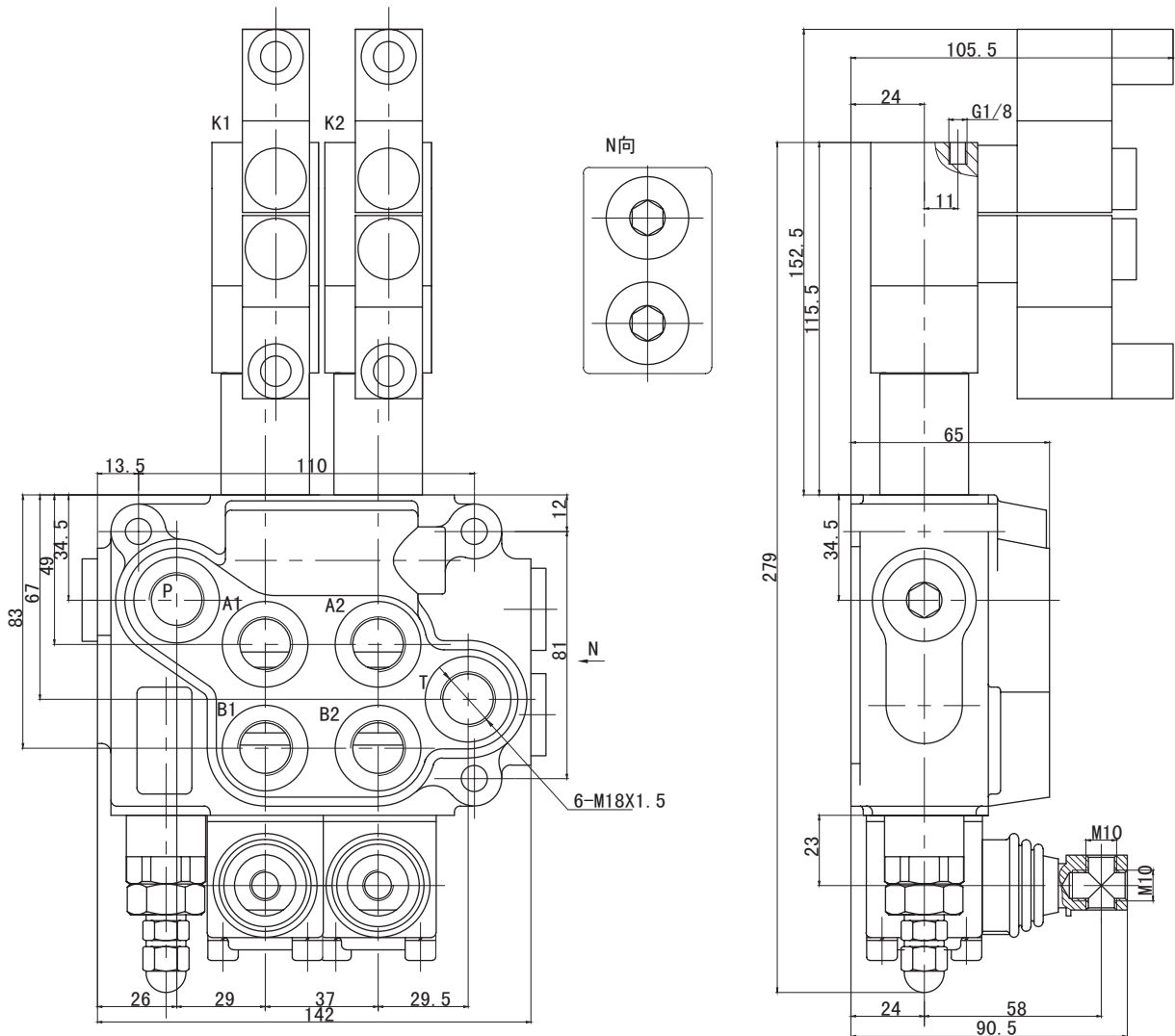

原理图

技术参数:

1. 公称通径 12mm
2. 公称压力 16MPa
3. 公称流量 50L/min
4. 工作气压 8Kg
5. 控制电压 DC12V/DC24V

注: 订货有特殊要求者, 请与销售顾问联系。

Note: Special features not listed can often be made to your specifications. Please consult your sales representative.

a37

DCV40电气控系列多路阀 MDCV

# DCV40电液控系列多路阀

## DCV40 Electric and Hydraulic Control Valve

### 产品描述/SPECIFICATION

DCV40电液控系列多路阀是在DCV40电气控系列的基础上研发而来。它主要是在没有气源的情况下实现使用的电动控制，并且保留了原本的手动控制，从主油路上分流出的一组控制油路，通过电磁阀来控制多路阀的换向工作，并且可以根据客户需求，安装无线遥控，能够更好地实现远程控制。

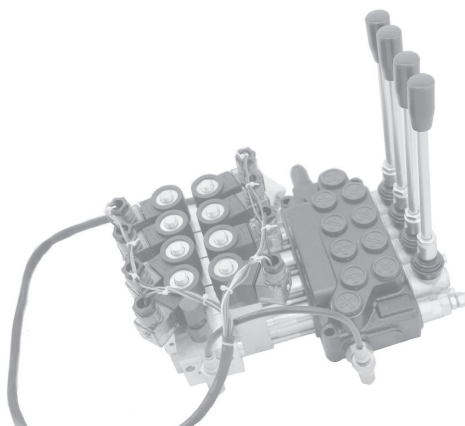

### 产品特点/FEATURES

- ◆ 内置单向阀：阀体内置单向阀，防止油液倒流
- ◆ 内置安全阀：阀体内置溢流阀，可调节控制系统压力
- ◆ 油路形式：并联油路，带压力输出口
- ◆ 控制方式：气控换向，也可手动换向
- ◆ 阀体结构：整体结构，1-8联任意组合
- ◆ 阀杆机能：O、A、Y等
- ◆ Inner check valve: The check valve inside the valve body to insure the hydraulic oil not be to returned.
- ◆ Inner relief valve: The relief valve inside the valve body is able to adjust the hydraulic system working pressure.
- ◆ Oil way: Parallel circuit, with power beyond.
- ◆ Control Way: electric and hydraulic control, manual control
- ◆ Valve construction: monoblock construction, 1-8 levers are available to be assembled as you requests.
- ◆ Spool Function: O,A,Y etc.

### 型号说明/MODEL CODE

DCV 40 / E7 (20) - O D 1 U-.....

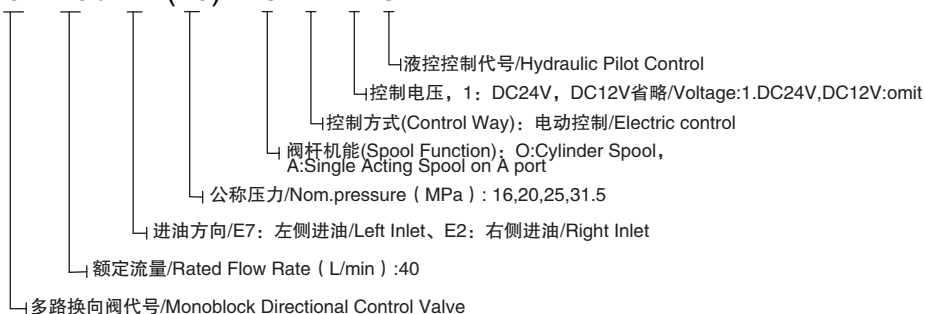

### 技术参数/PARAMETERS

公称压力 (MPa) Nom. Pressure	最大压力 (MPa) Max. Pressure	公称流量 (L/min) Nom. Flow rate	最大流量 (L/min) Max. Flow rate	中位背压 (MPa) Back Pressure	工作油液hydraulic oil		
					温度范围 (℃) Tem.rang	粘度范围 (mm <sup>2</sup> /S) Visc.rang	过滤精度 (μm) filtrating accuracy
20	31.5	40	50	≤2	-20 ~ +80	10 ~ 400	≤10

# DCV40电液控制系列多路阀

## DCV40 Electric and Hydraulic Control Valve

### DCV40外形安装连接尺寸/MODEL DCV40 DIMENSIONAL DATA

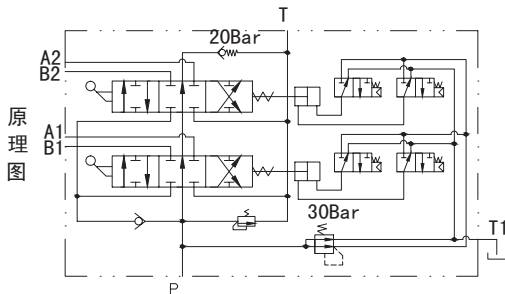
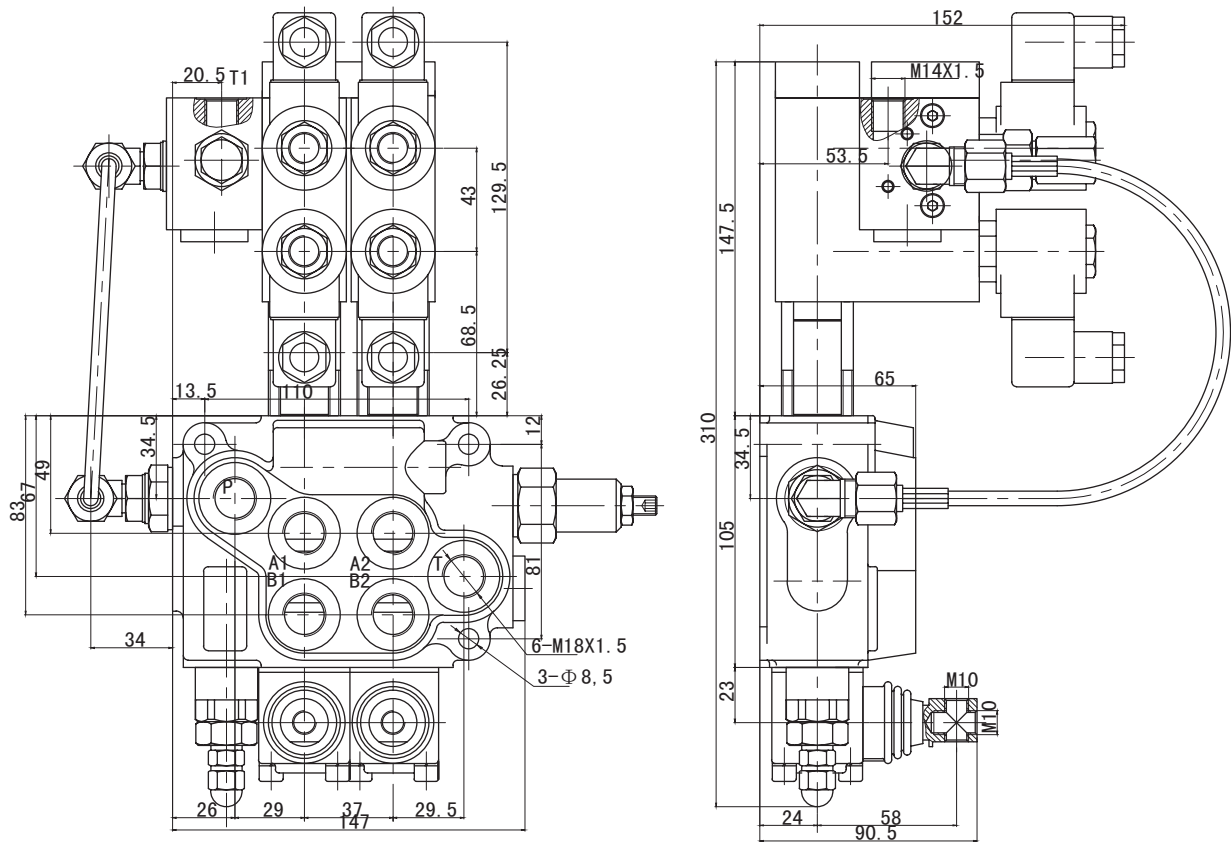

#### 技术参数:

1. 公称通径 12mm
2. 公称压力 16MPa
3. 最大流量 50L/min
4. 控制电压为直流12V。

注: 订货有特殊要求者, 请与销售顾问联系。

Note: Special features not listed can often be made to your specifications. Please consult your sales representative.

# ZD-L102系列整体阀

## ZD-L102 Series Monoblock Directional Control Valves.

### 用途与特征/APPLICATIONS&FEATURES

ZD-L102多路换向阀是我单位自主设计开发的一种中高压整体式多路换向阀。可按客户要求在上阀上设溢流阀、单向阀等。溢流阀可调节系统压力，单向阀防止油液倒流，换向阀滑阀机能能有A、O、Y、P等，可任意组合，换向手柄有两种安装形式，便于不同方向的操作，并采用并联油路。经过特殊设计的密封方式，使阀的密封性能卓越。该阀广泛用于叉车、环卫车辆、小型装载机等工程机械的液压系统。



Model ZD-L102 with middle-high pressure monoblock construction is an independently developed control valves by our company.

◆ Inner check valve: The check valve inside the valve body is to insure the hydraulic oil not to be returned.

◆ Inner relief valve: The relief valve inside the valve body is able to adjust the hydraulic system working pressure.

◆ Oil way: Parallel circuit

◆ Control Way: Manual control

◆ Valve construction: monoblock construction, 1-3 levers.

◆ Spool Function: O,Y,P,A.

### 性能参数/SPECIFICATIONS

公称压力 Nominal Pressure ( Mpa )	最大压力 Max. pressure ( Mpa )	公称流量 Nom. flow ( L/min )	允许背压 Allowable Back. pressure ( Mpa )	工作油液 Hydraulic Oil		
				温度范围 Tem.range ( °C )	粘度范围 Visc.range ( mm2/s )	过滤精度 Filtrating accuracy ( μm )
16	20	40	≤1	-20~+80	10~400	≤10

注：油液最高污染等级:按GB/T14039之19/16

Note: maximum permissible degree of contamination of the oil is according to GB/T14039-19/16

### 型号说明/MODEL CODE

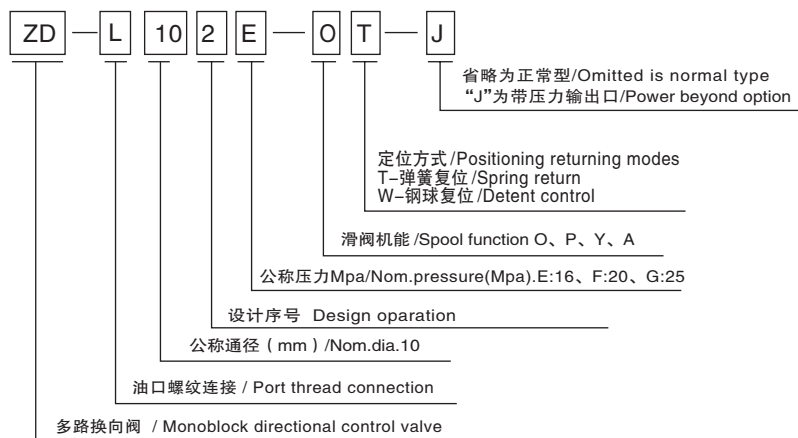

注：订货有特殊要求者，请与销售顾问联系。

Note: Specifical features not listed on can often be made to your specifications. Please consult your sales representative.

# ZD-L102系列整体阀

## ZD-L102 Series Monoblock Directional Control Valves.

### ZD-L102外形安装连接尺寸/MODEL ZD-L102 DIMENSIONAL DATA

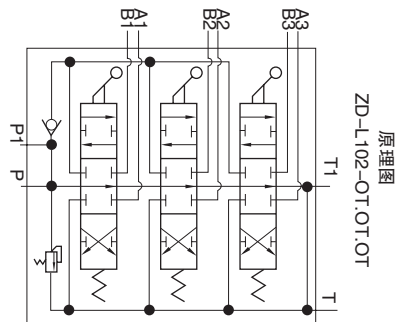
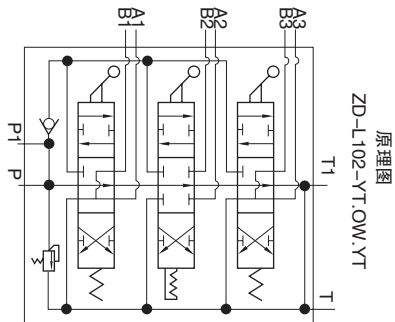
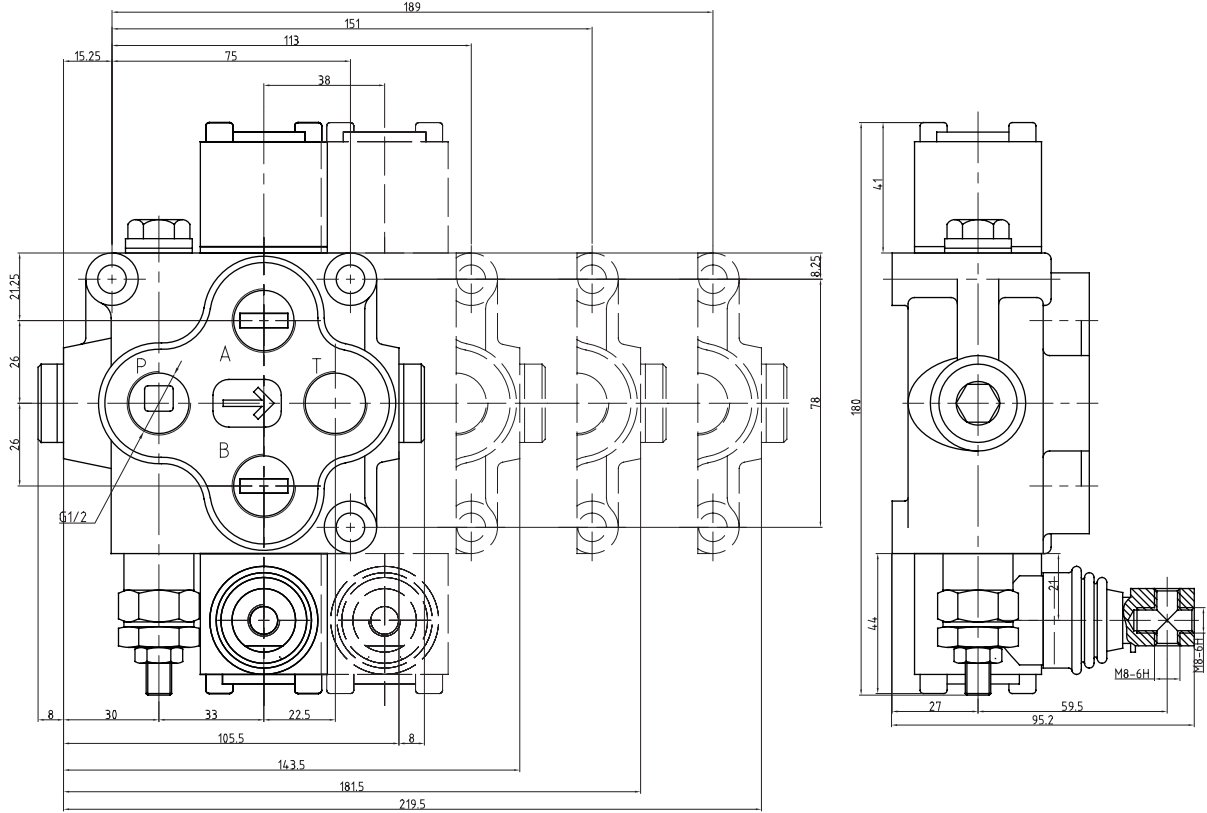

a41

ZD-L102系列整体阀MDCV

# BDL-L40系列整体阀

## BDL-L40 Series Monoblock Directional Control Valves.

### 用途与特征/APPLICATIONS&FEATURES

BDL-L40多路换向阀是我单位主要设计开发的一种中高压整体式换向阀，可按客户要求可在阀上设溢流阀。溢流阀可调节系统压力，换向阀机能有M.O.Y.P。该阀广泛用于叉车、环卫车辆、小型装载机等工程机械的液压系统。

Model BDL-L40 with middle-high pressure monoblock and single spool construction is an independently developed control valves by our company.

- ◆ Inner relief valve: The relief valve inside the valve body is able to adjust the hydraulic system working pressure.
- ◆ Oil way: Parallel circuit,
- ◆ Control Way: Manual control
- ◆ Valve construction: monoblock construction, single levers.
- ◆ Spool Function: M,O,Y, P.



### 性能参数/SPECIFICATIONS

公称压力 Nominal Pressure ( Mpa )	最大压力 Max. pressure ( Mpa )	公称流量 Nom. flow ( L/min )	允许背压 Allowable Back pressure ( Mpa )	工作油液Hydraulic Oil		
				温度范围 Tem.range ( °C )	粘度范围 Visc.range ( mm <sup>2</sup> /s )	过滤精度 Filtrating accuracy ( μm )
16	25	40	≤1	-20~+80	10~400	≤10

注：油液最高污染等级:按GB/T14039之19/16

Note: maximum permissible degree of contamination of the oil is according to GB/T14039-19/16

### 型号说明/MODEL CODE

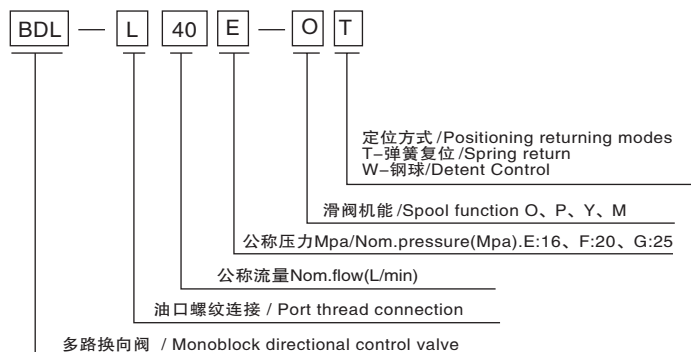

注：订货有特殊要求者，请与您的销售代表联系。

Notes:Special features not listed can often be made to your specifications, Please consult your sales representative.

# BDL-L40系列整体阀

## BDL-L40 Series Monoblock Directional Control Valves.

### BDL-L40外形安装连接尺寸/Model BDL-L40 DIMENSIONAL DATA

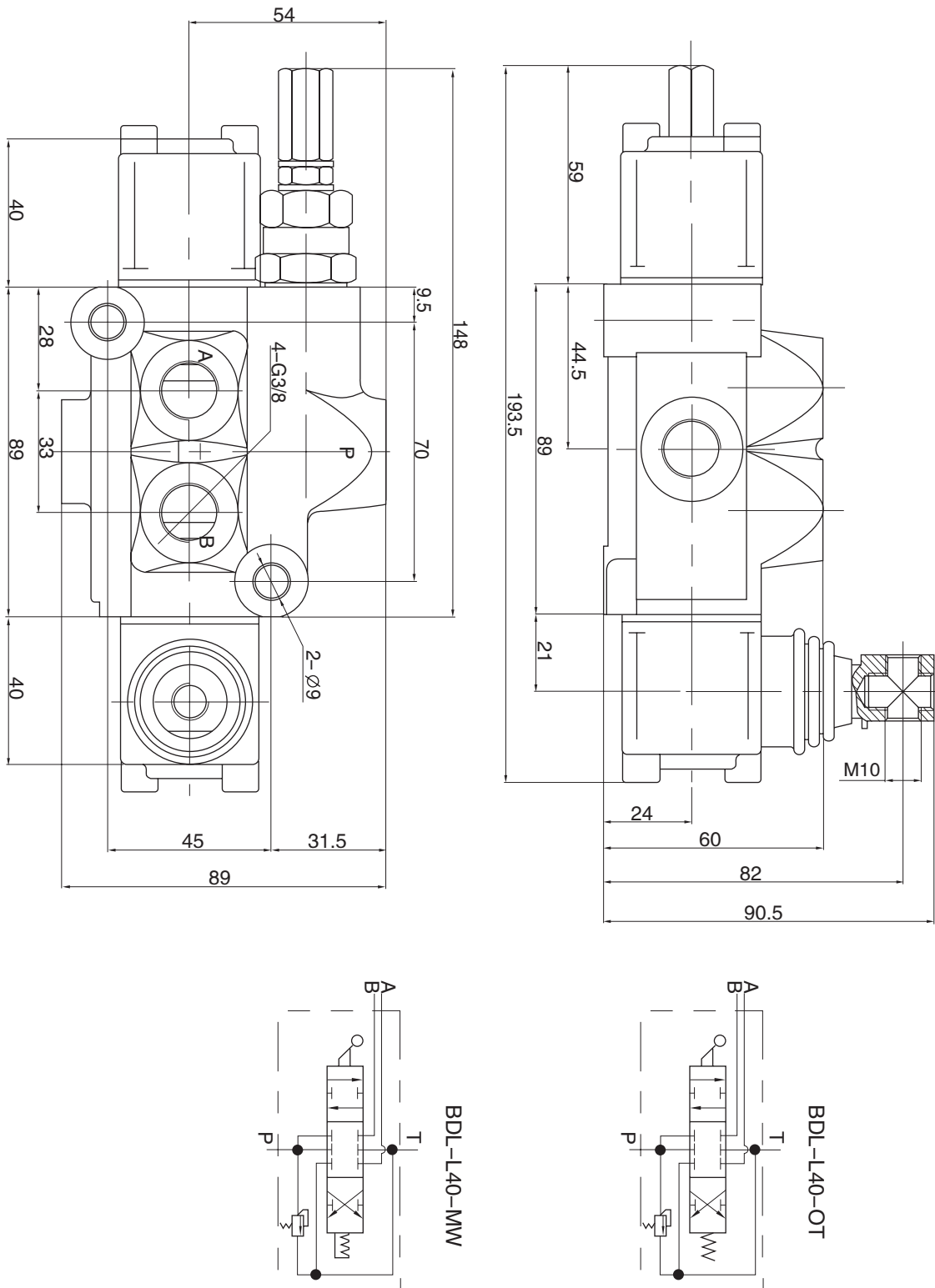

# ZD-L15系列整体阀

## ZD-L15 Series Monoblock Directional Control Valves.

### 用途与特征/APPLICATIONS&FEATURES

ZD-L15多路换向阀是我单位自主设计开发的一种中高压整体式多路换向阀。可按客户要求，在阀上设溢流阀、单向阀、补油阀等。溢流阀可调节系统压力，单向阀防止油液倒流，换向阀滑阀机能可有A、O、Y、P等，可任意组合。换向手柄有两种安装形式，便于不同方向的操作。该阀采用并联油路，设计有压力输出，与其它液压元件相接提供动力源。经过特殊设计的密封方式，使阀的密封性能卓越。该阀广泛用于叉车、环卫车辆、小型装载机等工程机械的液压系统。



Model ZD-L15 with middle-high pressure monoblock construction is an independently developed control valves by our company.

- ◆ Inner check valve: The check valve inside the valve body is to insure the hydraulic oil not to be returned.
- ◆ Inner relief valve: The relief valve inside the valve body is able to adjust the hydraulic system working pressure.
- ◆ Oil way: Parallel circuit, power beyond option
- ◆ Control Way: Manual control, pneumatic control, hydraulic and electric control for optional.
- ◆ Valve construction: monoblock construction, 2-4 levers.
- ◆ Spool Function: O, Y, P, A.

### 性能参数/SPECIFICATIONS

公称压力 Nominal Pressure (Mpa)	最大压力 Max. pressure (Mpa)	公称流量 Nom. flow (L/min)	允许背压 Allowable Back pressure (Mpa)	工作油液 Hydraulic Oil		
				温度范围 Tem. range (°C)	粘度范围 Visc. range (mm <sup>2</sup> /s)	过滤精度 Filtrating accuracy (μm)
16	31.5	63	≤1	-20~+80	10~400	≤10

注：油液最高污染等级：按GB/T14039之19/16  
Note: maximum permissible degree of contamination of the oil is according to GB/T14039-19/16

### 型号说明/MODEL CODE

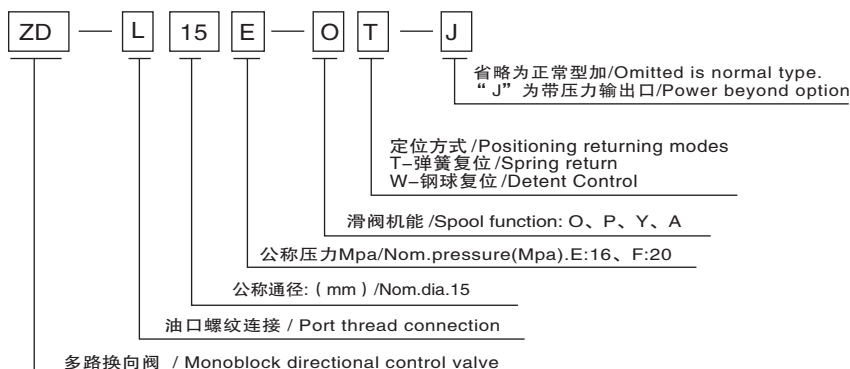

注：订货有特殊要求者，请与您的销售代表联系。  
Notes: Special features not listed can often be made to your specifications, Please consult your sales representative.

# ZD-L15系列整体阀

## ZD-L15 Series Monoblock Directional Control Valves.

### ZD-L15外形安装连接尺寸/MODEL ZD-L15 DIMENSIONAL DATA

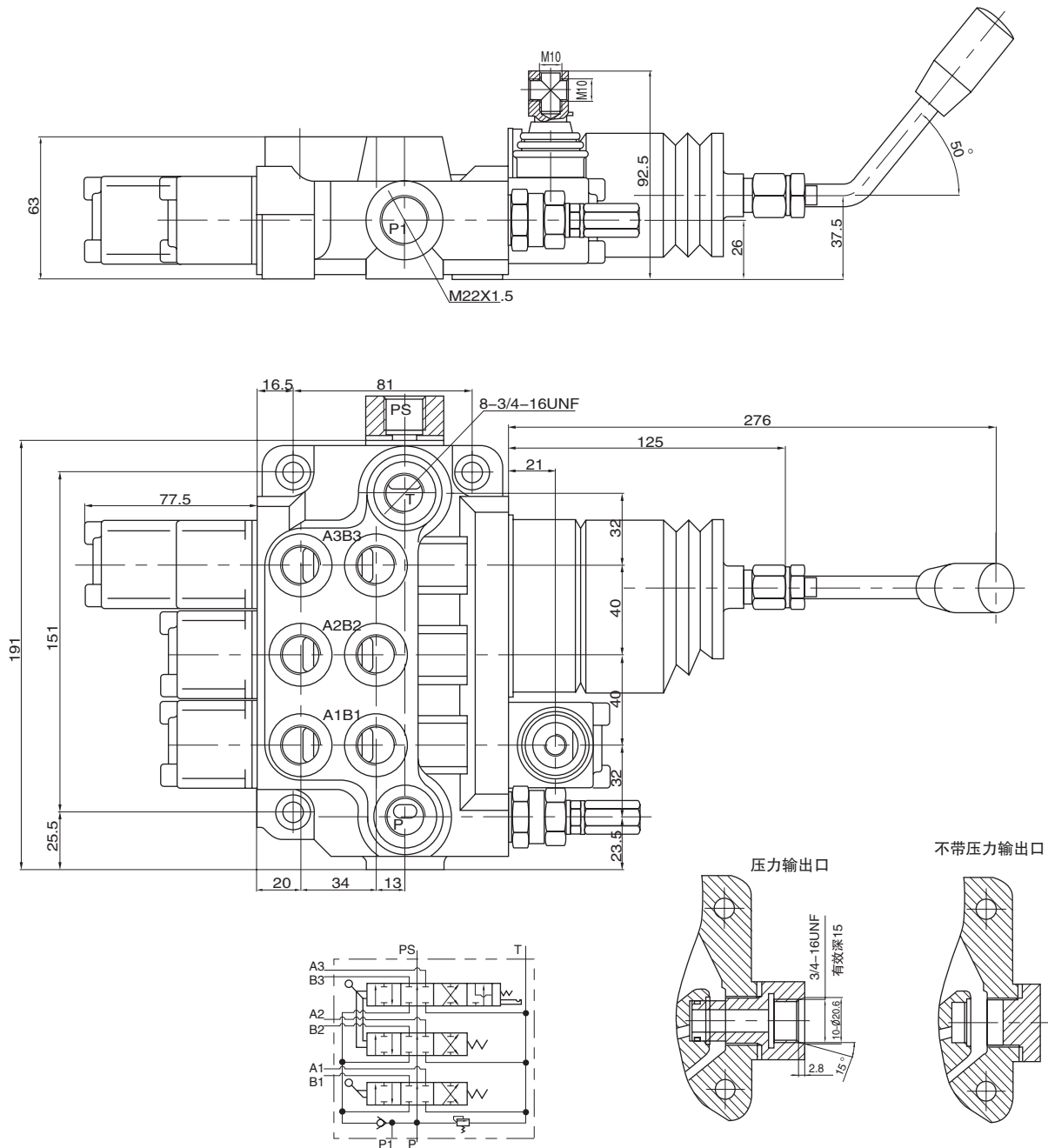

a45

ZD-L15系列整体阀MDCV

# ZD-L15气控系列多路阀

## ZD-L15 Pneumatic Control Valve

### 产品特点 / APPLICATIONS&FEATURES

ZD-L15气控系列多路阀是在ZD-L15手动控制系列的基础上改进而来。它主要是改变了手动换向阀的操纵机构，在手动的基础上增加了气动控制，能够更好地实现远程控制。ZD-L15系列多路阀的回油端设置了压力输出口，可与其他液压元件串联使用。该阀为整体式，具有结构紧凑，工作压力高，性能好，工作可靠，可实现多个执行机构的近、远程控制的优点。根据用户需要，换向阀的操纵机构可以和普通手动控制进行任意组合。该阀广泛应用于工程机械、环卫机械、矿山机械和其他机械的液压系统。

ZD-L15 series pneumatic control valves are developed on ZD-L15 manual control valves. It changed the control way of these valves, especially, it can be controlled by remote control with the pneumatic control way. The power beyond function is on the ZD-L15 series, it is able to be connected with other hydraulic valves in series. The features of the monoblock construction ZD-L15 pneumatic control valves are compact construction, high working pressure, better functions, reliable working, remote controlling and etc. Besides that, the manual control can be used with the pneumatic control together. The valves are widely used on mechanical machines, sanitation machines, mining machines and other machines' hydraulic systems.

◆ 内置单向阀：阀体内置单向阀，防止油液倒流

◆ Inner check valve: The check valve inside the valve body is to insure the hydraulic oil not be returned.

◆ 内置安全阀：阀体内置溢流阀，可调节控制系统压力

◆ Inner relief valve: The relief valve inside the valve body is able to adjust the hydraulic system working pressure.

◆ 油路形式：并联油路，带压力输出口

Oil way: Parallel circuit, with power beyond.

◆ 控制方式：气控换向，也可手动换向

Control Way: pneumatic control, manual control

◆ 阀体结构：整体结构，2-4联任意组合

Valve construction: monoblock construction, 2-4 levers are available to assembled as you requests.

◆ 阀杆机能：O、A、Y等

Spool Function: O,A,Y etc.

### 型号说明/MODEL CODE

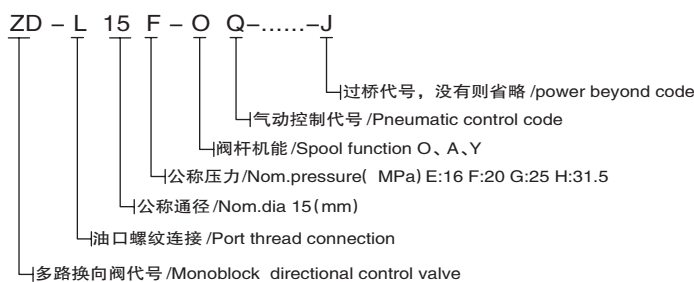

### 技术参数/PARAMETERS

公称压力 (MPa) Nom. Pressure	最大压力 (MPa) Max. Pressure	公称流量 (L/min) Nom. Flow rate	最大流量 (L/min) Max. Flow rate	中位背压 (MPa) Back Pressure	工作油液hydraulic oil		
					温度范围 (℃) Tem.rang	粘度范围 (mm <sup>2</sup> /S) Visc.rang	过滤精度 (μm) filtrating accuracy
20	31.5	50	60	≤1	-20 ~ +80	10 ~ 400	≤10

注：订货有特殊要求者，请与您的销售代表联系。

Notes:Special features not listed can often be made to your specifications, Please consult your sales representative.

# ZD-L15气控系列多路阀

## ZD-L15 Pneumatic Control Valve

### ZD-L15外形安装连接尺寸/MODEL ZD-L15 DIMENSIONAL DATA

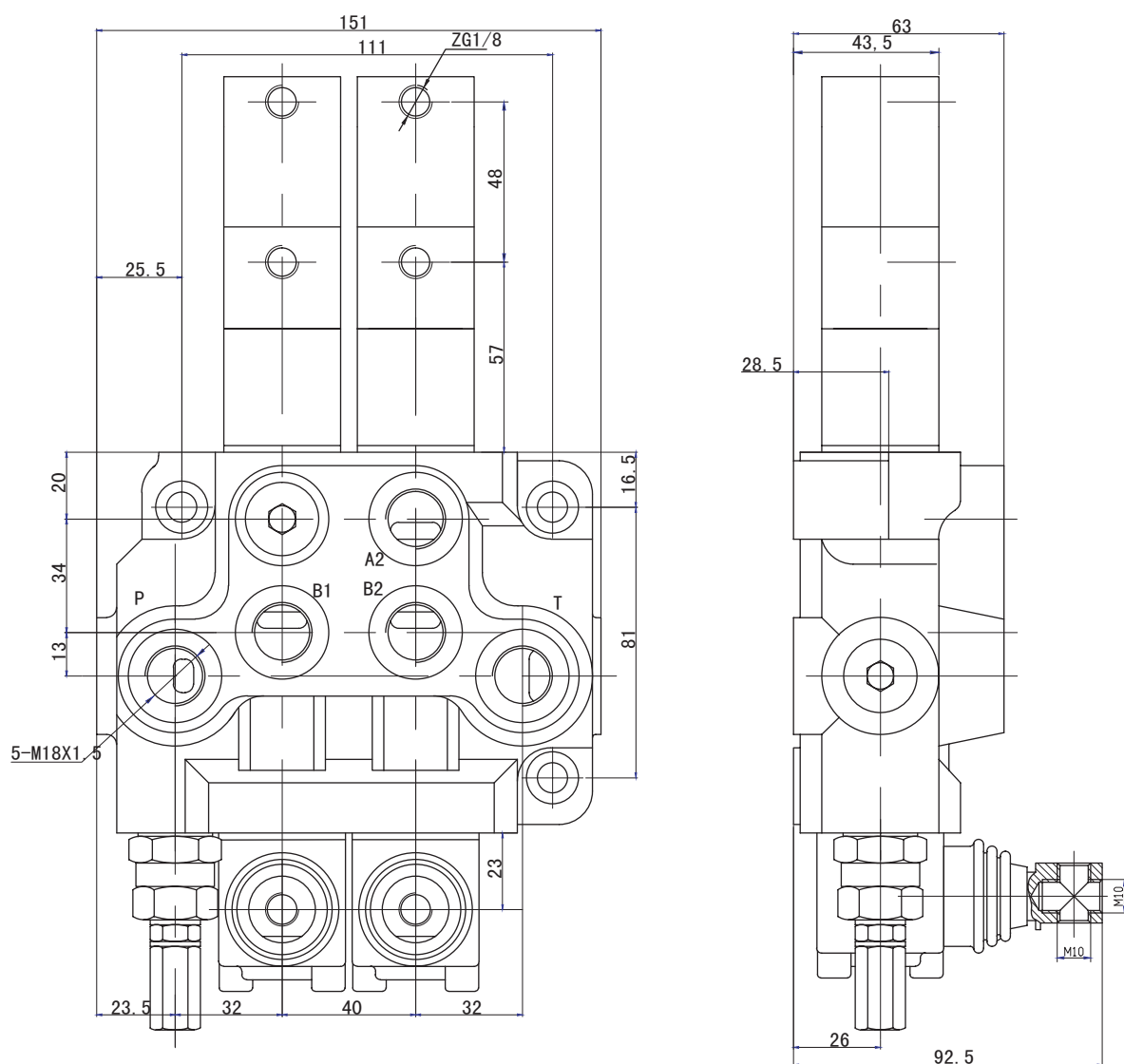

原  
理  
图

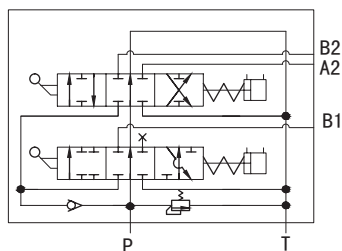

技术参数:

1. 公称通径: 15mm
2. 公称压力: 16MPa,
3. 最大流量: 60L/min.

a47

ZD-L15气控系列多路阀MDCV

# ZD-L15电气控系列整体阀

## ZD-L15 Electric and Pneumatic Control Valve

### 用途与特征/APPLICATIONS&FEATURES

ZD-L15电气控制系列多路阀是在ZD-L15气控系列的基础上改进而来。它主要是改变了气控换向阀的操纵机构，在气控的基础上增加了电气控制，并且可以根据客户需求，安装无线遥控，能够更好地实现远程控制。该阀广泛应用于工程机械、环卫机械、矿山机械和其他机械的液压系统。

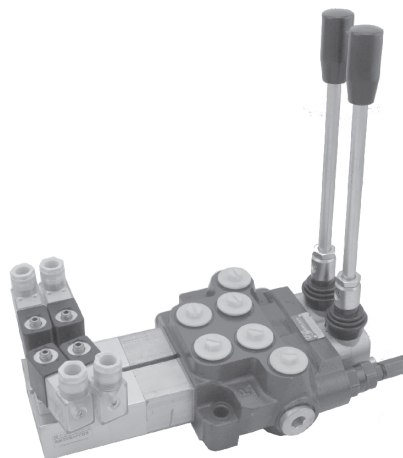

### 产品特点/FEATURES

- ◆ 内置单向阀：阀体内置单向阀，防止油液倒流
- ◆ 内置安全阀：阀体内置溢流阀，可调节控制系统压力
- ◆ 油路形式：并联油路，带压力输出口
- ◆ 控制方式：气控换向，也可手动换向
- ◆ 阀体结构：整体结构，2-4联任意组合
- ◆ 阀杆机能：O、A、Y等
- ◆ Inner check valve: The check valve inside the valve body to insure the hydraulic oil not to be returned.
- ◆ Inner relief valve: The relief valve inside the valve body is able to adjust the hydraulic system working pressure.
- ◆ Oil way: Parallel circuit, with power beyond.
- ◆ Control Way: pneumatic control, manual control
- ◆ Valve construction: monoblock construction, 2-4 levers are available to be assembled as you requests.
- ◆ Spool Function: O,A,Y etc.

### 性能参数/SPECIFICATIONS

公称压力 (MPa) Nom. Pressure	最大压力 (MPa) Max. Pressure	公称流量 (L/min) Nom. Flow rate	最大流量 (L/min) Max. Flow rate	中位背压 (MPa) Back Pressure	工作油液hydraulic oil		
					温度范围 (℃) Tem.rang	粘度范围 (mm <sup>2</sup> /S) Visc.rang	过滤精度 (μm) filtrating accuracy
20	31.5	50	60	≤1	-20 ~ +80	10 ~ 400	≤10

注：油液最高污染等级:按GB/T14039之19/16

Note: maximum permissible degree of contamination of the oil is according to GB/T14039-19/16

### 型号说明/MODEL CODE

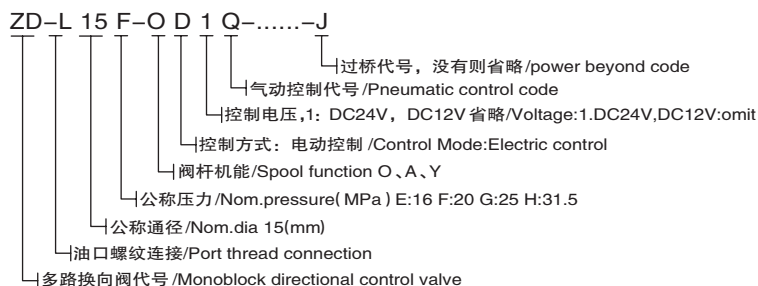

注：订货有特殊要求者，请与您的销售代表联系。

Notes:Special features not listed can often be made to your specifications, Please consult your sales representative.

# ZD-L15电气控系列整体阀

## ZD-L15 Series Electric and Pneumatic Directional Control Valves

### ZD-L15外形安装连接尺寸 / MODEL ZD-L15 DIMENSIONAL DATA

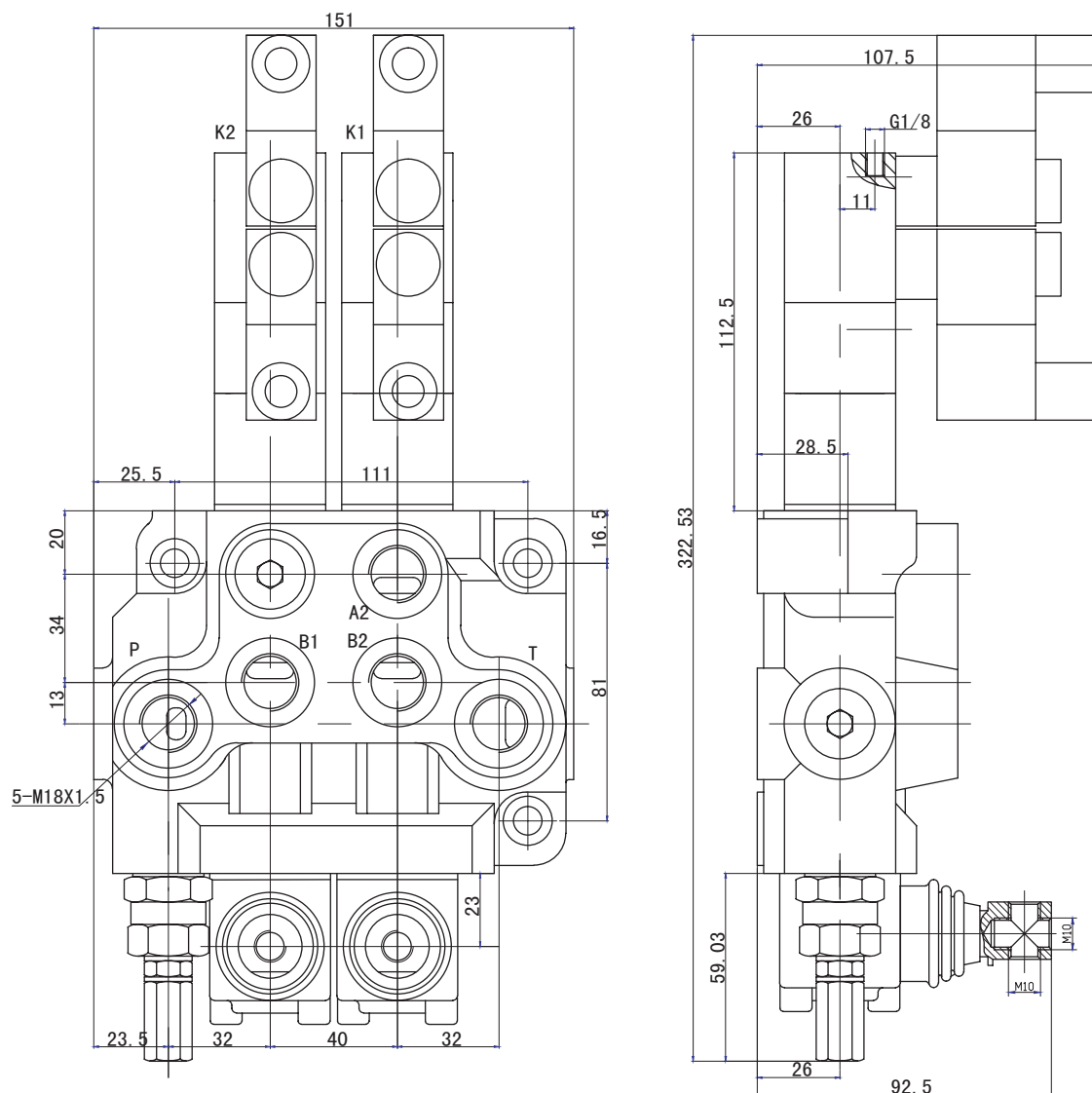

原  
理  
图

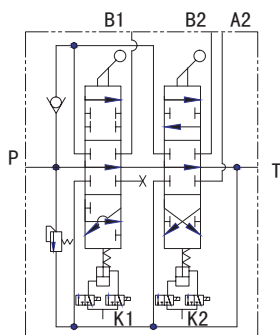

技术参数:

1. 公称通径: 15mm
2. 公称压力: 16MPa,
3. 最大流量: 60L/min.

# ZDa-L15系列整体阀

## ZDa-L15 Series Monoblock Directional Control Valves.

### 用途与特征/APPLICATIONS&FEATURES

ZDa-L15多路换向阀是我单位自主设计开发的一种中高压整体式多路换向阀。可按客户要求在上阀设溢流阀、单向阀。溢流阀可调节系统压力，单向阀防止油液倒流，换向阀滑阀机能可有A、O、Y、P等，可任意组合。换向手柄有两种安装形式，便于不同方向的操作，该阀采用并联油路，设计有压力出口与其它液压元件相接提供动力源。经过特殊设计的密封方式，使阀的密封性能卓越。该阀广泛用于叉车、环卫车辆、小型装载机等工程机械的液压系统。



Model ZDa-L15 with middle-high pressure monoblock construction is an independently developed control valves by our company.

- ◆ Inner check valve: The check valve inside the valve body is to insure the hydraulic oil not to be returned.
- ◆ Inner relief valve: The relief valve inside the valve body is able to adjust the hydraulic system working pressure.
- ◆ Oil way: Parallel circuit, power beyond option
- ◆ Control Way: Manual control, pneumatic control, hydraulic and electric control for optional.
- ◆ Valve construction: monoblock construction, 1-7 levers.
- ◆ Spool Function: O, Y, P, A.
- ◆ The valve is widely used in the hydraulic system of forklift, environment vehicle and light loading machines.

### 性能参数/SPECIFICATIONS

公称压力 Nominal Pressure ( Mpa )	最大压力 Max. pressure ( Mpa )	公称流量 Nom. flow ( L/min )	允许背压 Allowable Back. pressure ( Mpa )	工作油液 Hydraulic Oil		
				温度范围 Tem.range ( °C )	粘度范围 Visc.range ( mm <sup>2</sup> /s )	过滤精度 Filtrating accuracy ( μm )
16	31.5	63	≤1	-20~+80	10~400	≤10

注：油液最高污染等级：按GB/T14039之19/16

Note: maximum permissible degree of contamination of the oil is according to GB/T14039-19/16

# ZDa-L15系列整体阀

## ZDa-L15 Series Monoblock Directional Control Valves.

### 型号说明/MODEL CODE

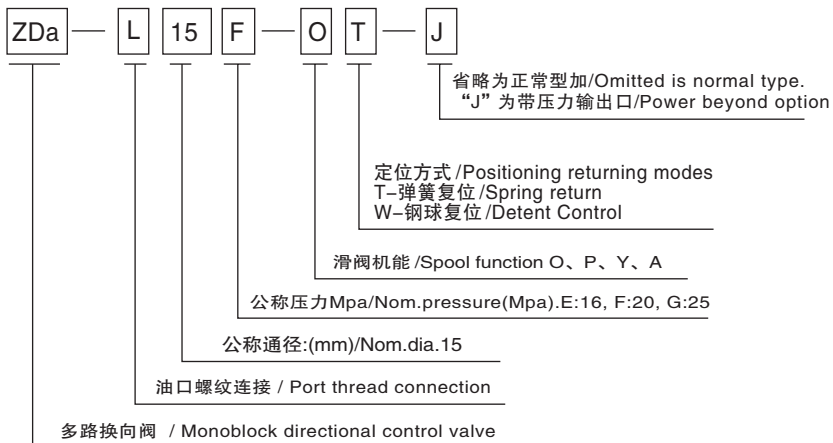

注: 订货有特殊要求者, 请与销售顾问联系。  
Note: Special features not listed can often be made to your specifications. Please consult your sales representative.

### ZDa-L15外形安装连接尺寸/MODEL ZDa-L15 DIMENSIONAL DATA

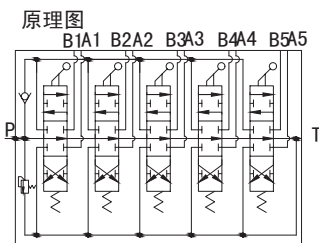
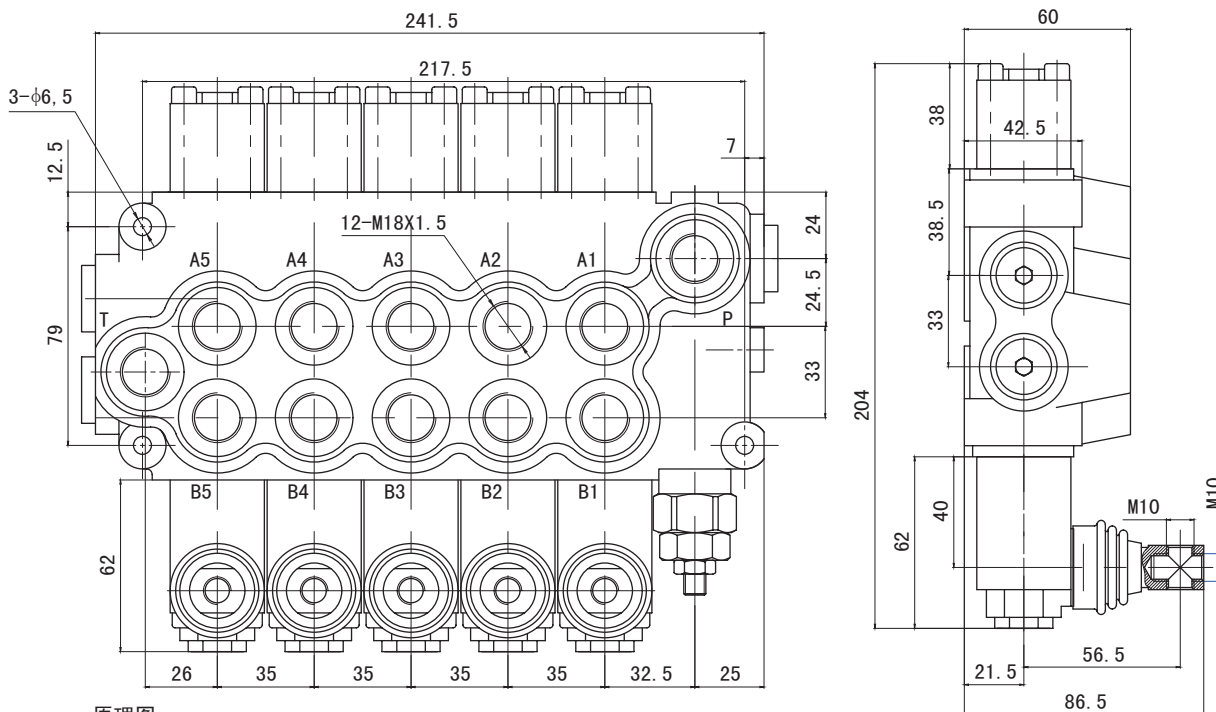

- 技术参数:
1. 公称口径 15mm
  2. 公称压力 20MPa
  3. 最大流量 63L/min

a51

ZDa-L15系列整体阀MDCV

# ZDa-L15气控系列多路阀

## ZDa-L15 Pneumatic Control Valve

### 产品描述/SPECIFICATION

ZDa-L15气控系列多路阀是在ZDa-L15手动控制系列的基础上改进而来。它主要是改变了手动换向阀的操纵机构，在手动的基础上增加了气动控制，能够更好地实现远程控制。ZDa-L15系列多路阀的回油端设置了压力输出口，可与其他液压元件串联使用。该阀为整体式，具有结构紧凑，工作压力高，性能好，工作可靠，可实现多个执行机构的近、远程控制的优点。该阀广泛应用于工程机械、环卫机械、矿山机械和其他机械的液压系统。



### 产品特点/FEATURES

- ◆ 内置单向阀：阀体内置单向阀，防止油液倒流
- ◆ 内置安全阀：阀体内置溢流阀，可调节控制系统压力
- ◆ 油路形式：并联油路，带压力输出口
- ◆ 控制方式：气控换向，也可手动换向
- ◆ 阀体结构：整体结构，1-7联任意组合
  - ◆ 阀杆机能：O、A、Y等
  - ◆ Inner check valve: The check valve inside the valve body to insure the hydraulic oil not to be returned.
  - ◆ Inner relief valve: The relief valve inside the valve body is able to adjust the hydraulic system working pressure.
  - ◆ Oil way: Parallel circuit, with power beyond.
  - ◆ Control Way: pneumatic control, manual control
  - ◆ Valve construction: monoblock construction, 1-7 levers are available to assembled as you requests.
  - ◆ Spool Function: O,A,Y etc.

### 型号说明/MODEL CODE

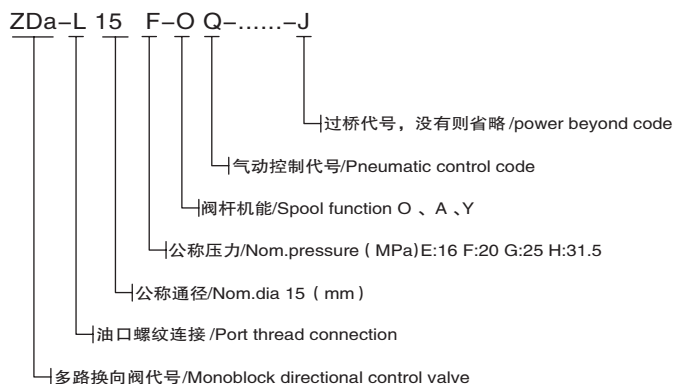

### 性能参数/SPECIFICATIONS

公称压力 (MPa) Nom. Pressure	最大压力 (MPa) Max. Pressure	公称流量 (L/min) Nom. Flow rate	最大流量 (L/min) Max. Flow rate	中位背压 (MPa) Back Pressure	工作油液hydraulic oil		
					温度范围 (℃) Tem.rang	粘度范围 (mm <sup>2</sup> /S) Visc.rang	过滤精度 (μm) filtrating accuracy
20	31.5	50	60	≤1	-20 ~ +80	10 ~ 400	≤10

# ZDa-L15气控系列多路阀

## ZDa-L15 Pneumatic Control Valve

### ZDa-L15 外形安装连接尺寸/MODEL ZDa-L15 DIMENSIONAL DATA

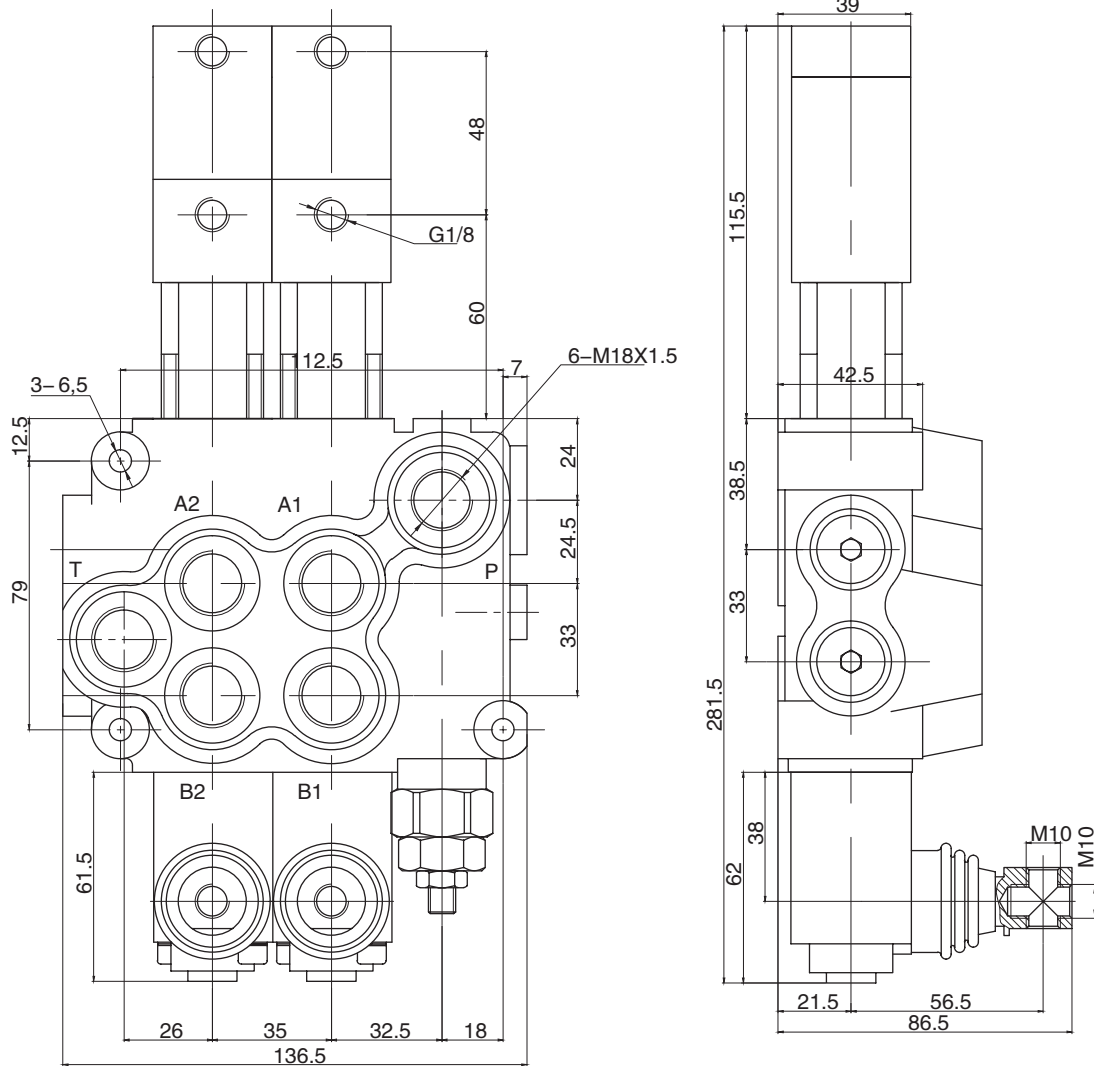

技术参数:

- 1.公称通径 15mm
- 2.公称压力 16MPa
- 3.公称流量 60L/min
- 4.工作气压 8Kg

注: 订货有特殊要求者, 请与销售顾问联系。

Note: Special features not listed can often be made to your specifications. Please consult your sales representative.

# ZDa-L15电气控系列多路阀

## ZDa-L15 Electric and Pneumatic Control Valve

### 产品描述/SPECIFICATION

ZDa-L15电气控系列多路阀是在ZDa-L15气控系列的基础上改进而来。它主要是改变了气控换向阀的操纵机构，在气控的基础上增加了电气控制，并且可以根据客户需求，安装无线遥控，能够更好地实现远程控制。该阀广泛应用于工程机械、环卫机械、矿山机械和其他机械的液压系统。

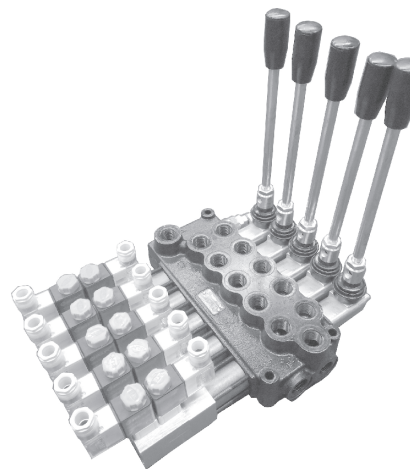

### 产品特点/FEATURES

- ◆ 内置单向阀：阀体内置单向阀，防止油液倒流
- ◆ 内置安全阀：阀体内置溢流阀，可调节控制系统压力
- ◆ 油路形式：并联油路，带压力输出口
- ◆ 控制方式：气控换向，也可手动换向
- ◆ 阀体结构：整体结构，1-7联任意组合
- ◆ 阀杆机能：O、A、Y等
- ◆ Inner check valve: The check valve inside the valve body to insure the hydraulic oil not to be returned.
- ◆ Inner relief valve: The relief valve inside the valve body is able to adjust the hydraulic system working pressure.
- ◆ Oil way: Parallel circuit, with power beyond.
- ◆ Control Way: pneumatic control, manual control
- ◆ Valve construction: monoblock construction, 1-7 levers are available to assembled as you requests.
- ◆ Spool Function: O,A,Y etc.

### 型号说明/MODEL CODE

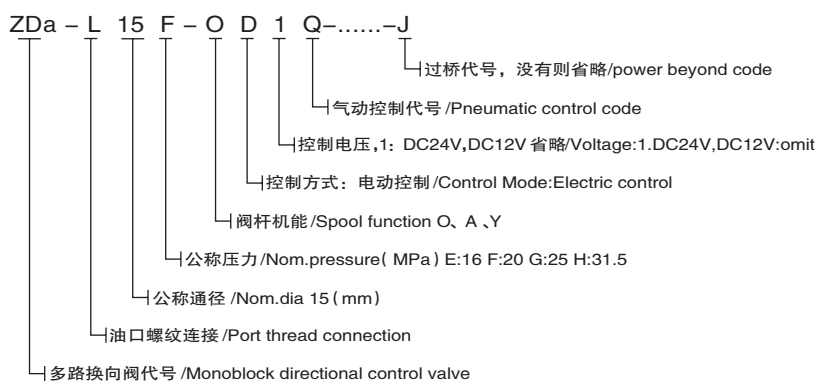

### 性能参数/SPECIFICATIONS

公称压力 ( MPa ) Nom. Pressure	最大压力 ( MPa ) Max. Pressure	公称流量 ( L/min ) Nom. Flow rate	最大流量 ( L/min ) Max. Flow rate	中位背压 ( MPa ) Back Pressure	工作油液 hydraulic oil		
					温度范围 ( °C ) Tem.rang	粘度范围 ( mm <sup>2</sup> /S ) Visc.rang	过滤精度 ( μm ) filtrating accuracy
20	31	50	60	≤1	-20 ~ +80	10 ~ 400	≤10

# ZDa-L15电气控系列多路阀

## ZDa-L15 Electric and Pneumatic Control Valve

### ZDa-L15 外形安装连接尺寸/MODEL ZDa-L15 DIMENSIONAL DATA

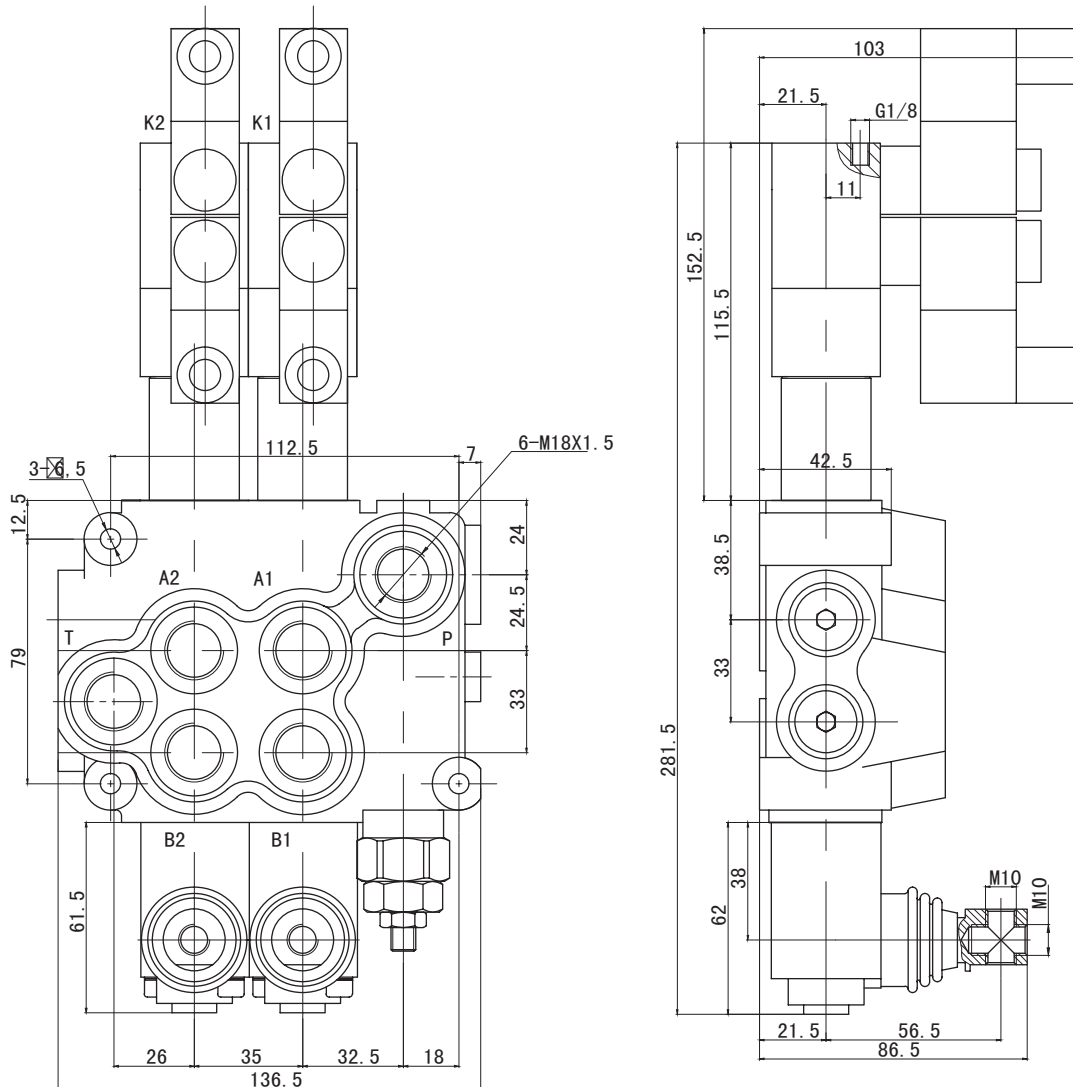

#### 技术参数:

1. 公称通径 15mm
2. 公称压力 16MPa
3. 公称流量 60L/min
4. 工作气压 8Kg
5. 控制电压 DC12V

注: 订货有特殊要求者, 请与销售顾问联系。

Note: Special features not listed can often be made to your specifications. Please consult your sales representative.

# ZDa-L15电液控系列多路阀

## ZDa-L15 Electric and Hydraulic Control Valve

### 产品描述/SPECIFICATION

ZDa-L15电液控系列多路阀是在ZDa-L15电气控系列的基础上研发而来。它主要是在没有气源的情况下实现使用的电动控制，并且保留了原本的手动控制，从主油路上分流出的一组控制油路，通过电磁阀来控制多路阀的换向工作，并且可以根据客户需求，安装无线遥控，能够更好地实现远程控制。该阀广泛应用于工程机械、环卫机械、矿山机械和其他机械的液压系统。

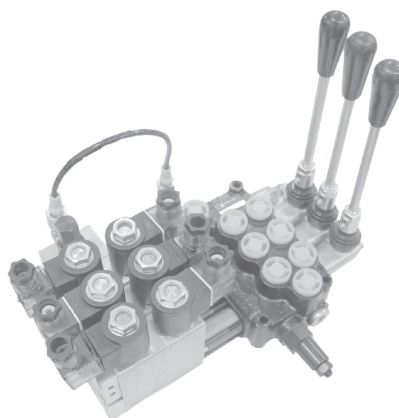

### 产品特点/FEATURES

- ◆ 内置单向阀：阀体内置单向阀，防止油液倒流
- ◆ 内置安全阀：阀体内置溢流阀，可调节控制系统压力
- ◆ 油路形式：并联油路，带压力输出口
- ◆ 控制方式：气控换向，也可手动换向
- ◆ 阀体结构：整体结构，1-7联任意组合
- ◆ 阀杆机能：O、A、Y等
- ◆ Inner check valve: The check valve inside the valve body to insure the hydraulic oil not to be returned.
- ◆ Inner relief valve: The relief valve inside the valve body is able to adjust the hydraulic system working pressure.
- ◆ Oil way: Parallel circuit, with power beyond.
- ◆ Control Way: hydraulic and electric control, manual control
- ◆ Valve construction: monoblock construction, 1-7 levers are available to assembled as you requests.
- ◆ Spool Function: O,A,Y etc.

### 型号说明/MODEL CODE

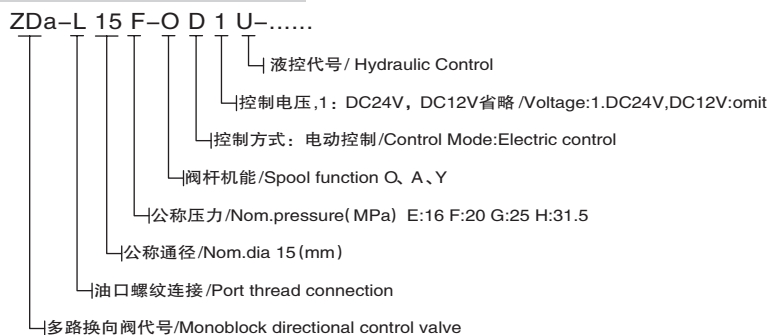

### 性能参数/SPECIFICATIONS

公称压力 (MPa) Nom. Pressure	最大压力 (MPa) Max. Pressure	公称流量 (L/min) Nom. Flow rate	最大流量 (L/min) Max. Flow rate	中位背压 (MPa) Back Pressure	工作油液 hydraulic oil		
					温度范围 (°C) Tem.rang	粘度范围 (mm <sup>2</sup> /S) Visc.rang	过滤精度 (μm) filtrating accuracy
20	31.5	50	60	≤2	-20 ~ +80	10 ~ 400	≤10

# ZDa-L15电液控系列多路阀

## ZDa-L15 Electric and Hydraulic Control Valve

### ZDa-L15 外形安装连接尺寸/MODEL ZDa-L15 DIMENSIONAL DATA

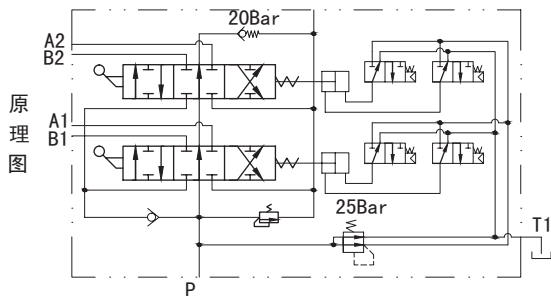
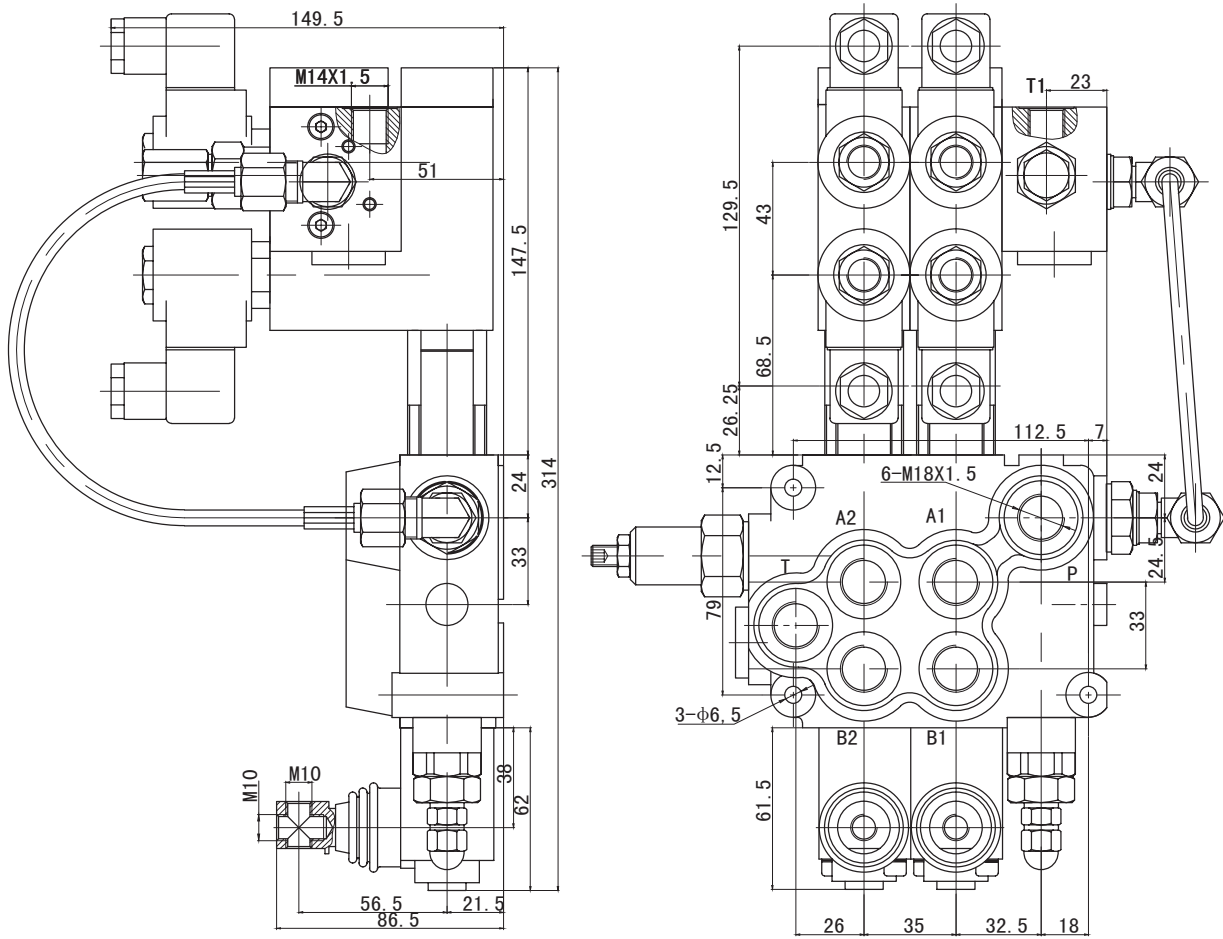

- 技术参数:
1. 公称通径 15mm
  2. 公称压力 16MPa
  3. 最大流量 60L/min
  4. 控制电压为直流12V。

注: 订货有特殊要求者, 请与销售顾问联系。  
 Note: Special features not listed can often be made to your specifications. Please consult your sales representative.

# ZT-L20系列整体阀

## ZT-L20 Series Monoblock Directional Control Valves.

### 用途与特征/APPLICATIONS&FEATURES

ZT-L20多路换向阀是我单位自主设计开发的一种中高压整体式多路换向阀。可按客户要求可在阀上设溢流阀、单向阀、液压锁。溢流阀可调节系统压力，单向阀防止油液倒流，换向阀滑阀机能A、O、Y、P等，可任意组合，换向手柄有两种安装形式，便于不同方向的操作，该阀采用并联油路，设计有压力输出口与其它液压元件相接提供动力源。经过特殊设计的密封方式，使阀的密封性能卓越。该阀广泛用于叉车、环卫车辆、小型装载机等工程机械的液压系统。

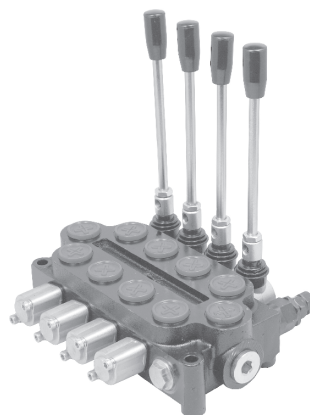

Model ZT-L20 with middle-high pressure monoblock construction is an independently developed control valves by our company.

- ◆ Inner check valve: The check valve inside the valve body is to insure the hydraulic oil not to be returned.
- ◆ Inner relief valve: The relief valve inside the valve body is able to adjust the hydraulic system working pressure.
- ◆ Oil way: Parallel circuit, power beyond option
- ◆ Control Way: Manual control, pneumatic control, hydraulic and electric control for optional.
- ◆ Valve construction: monoblock construction, 1-5 levers.
- ◆ Spool Function: O, Y, P, A.
- ◆ Option: Hydraulic lock is available to be added on A and B port.
- ◆ The valve is widely used in the hydraulic system of forklift, environment vehicle and light loading machines.

### 性能参数/SPECIFICATIONS

公称压力 Nominal Pressure ( Mpa )	最大压力 Max. pressure ( Mpa )	公称流量 Nom. flow ( L/min )	允许背压 Allowable Back. pressure ( Mpa )	工作油液 Hydraulic Oil		
				温度范围 Tem.range ( °C )	粘度范围 Visc.range ( mm <sup>2</sup> /s )	过滤精度 Filtrating accuracy ( μm )
20	31.5	90	≤1	-20~+80	10~400	≤10

注：油液最高污染等级：按GB/T14039之19/16

Note: maximum permissible degree of contamination of the oil is according to GB/T14039-19/16

# ZT-L20系列整体阀

## ZT-L20 Series Monoblock Directional Control Valves.

### 型号说明/MODEL CODE

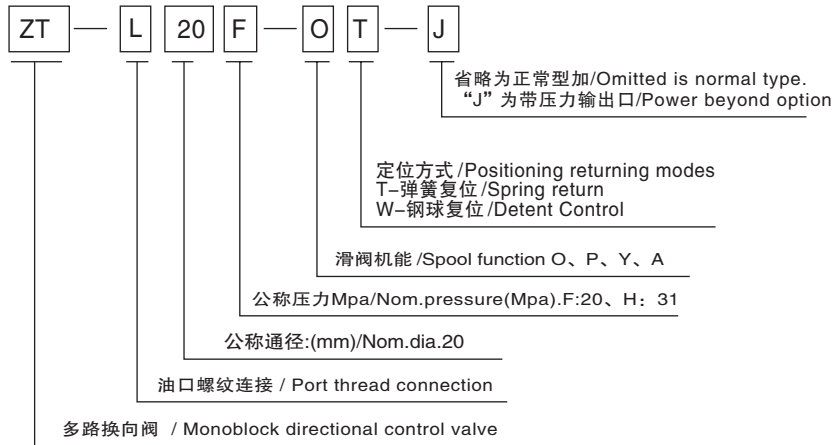

注：订货有特殊要求者，请与销售顾问联系。

Note: Special features not listed can often be made to your specifications. Please consult your sales representative.

### ZT-L20 外形安装连接尺寸/MODEL ZT-L20 DIMENSIONAL DATA

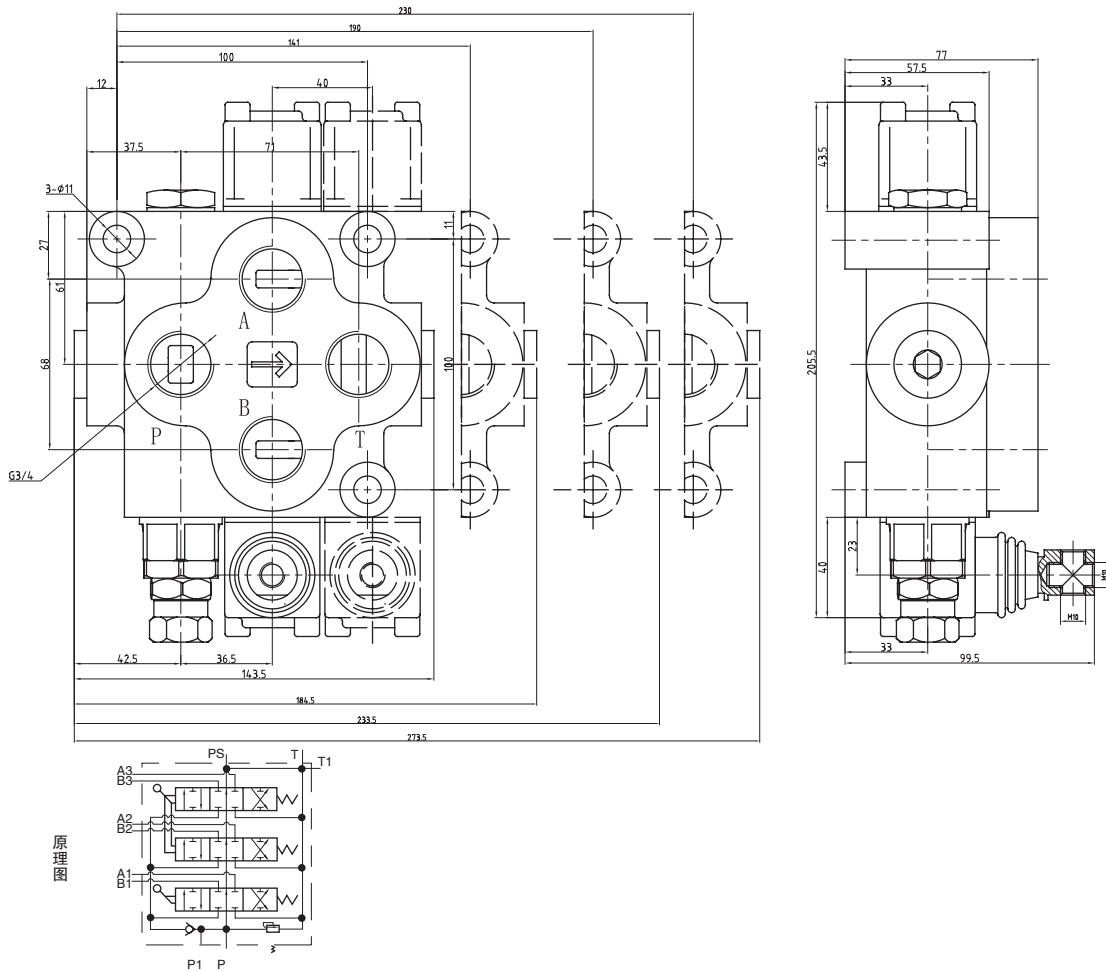

# ZT-L20气控系列多路阀

## ZT-L20 Pneumatic Control Valve

### 用途与特征/APPLICATIONS&FEATURES

ZT-L20气控系列多路阀是在ZT-L20手动控制系列的基础上改进而来。它主要是改变了手动换向阀的操纵机构，在手动的基础上增加了气动控制，能够更好地实现远程控制。ZT-L20系列多路阀的回油端设置了压力输出口，可与其他液压元件串联使用。该阀为整体式，具有结构紧凑，工作压力高，性能好，工作可靠，可实现多个执行机构的近、远程控制的优点。根据用户需要，换向阀的操纵机构可以和普通手动控制进行任意组合。该阀广泛应用于工程机械、环卫机械、矿山机械和其他机械的液压系统。



ZT-L20 series pneumatic control valves are developed on ZT-L20 manual control valves. It changed the control way of these valves, especially, it can be controlled by remote control with the pneumatic control way. The power beyond function is on the ZT-L20 series, it is able to be connected with other hydraulic valves in series. The features of this monoblock construction ZT-L20 pneumatic control valves are compact construction, high working pressure, better working performance, reliable working, remote controlling and etc. Besides that, the manual control can be used with the pneumatic control together. The valves are widely used on mechanical machines, sanitation machines, mining machines and other machines' hydraulic systems.

- ◆ 内置单向阀：阀体内置单向阀，防止油液倒流  
Inner check valve: The check valve inside the valve body is to insure the hydraulic oil not to be returned.
- ◆ 内置安全阀：阀体内置溢流阀，可调节控制系统压力  
Inner relief valve: The relief valve inside the valve body is able to adjust the hydraulic system working pressure.
- ◆ 油路形式：并联油路，带压力输出口  
Oil way: Parallel circuit, with power beyond.
- ◆ 控制方式：气控换向，也可手动换向  
Control Way: pneumatic control, manual control
- ◆ 阀体结构：整体结构，1-5联任意组合  
Valve construction: monoblock construction, 1-5 levers are available to assembled as you requests.
- ◆ 阀杆机能：O、A、Y等  
Spool Function: O,A,Y etc.

### 型号说明/MODEL CODE

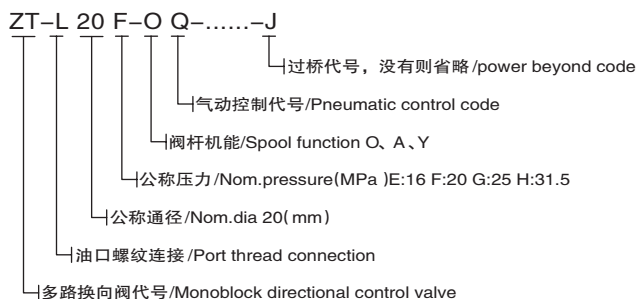

### 性能参数/SPECIFICATIONS

公称压力 (MPa) Nom. Pressure	最大压力 (MPa) Max. Pressure	公称流量 (L/min) Nom. Flow rate	最大流量 (L/min) Max. Flow rate	中位背压 (MPa) Back Pressure	工作油液hydraulic oil		
					温度范围 (℃) Tem.rang	粘度范围 (mm <sup>2</sup> /S) Visc.rang	过滤精度 (μm) filtrating accuracy
20	31.5	80	100	≤1	-20 ~ +80	10 ~ 400	≤10

# ZT-L20气控系列多路阀

## ZT-L20 Pneumatic Control Valve

### ZT-L20 外形安装连接尺寸/MODEL ZT-L20 DIMENSIONAL DATA

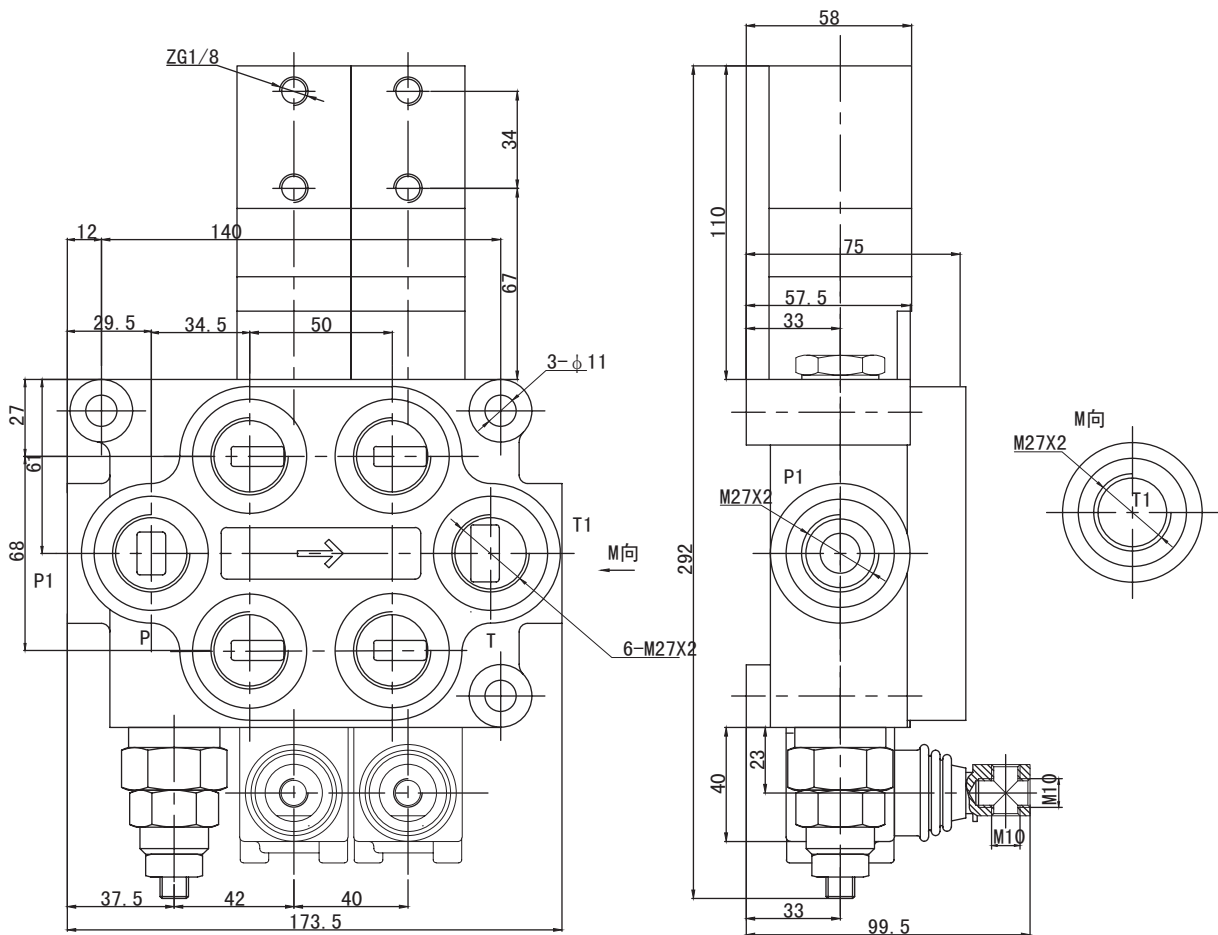

原理图

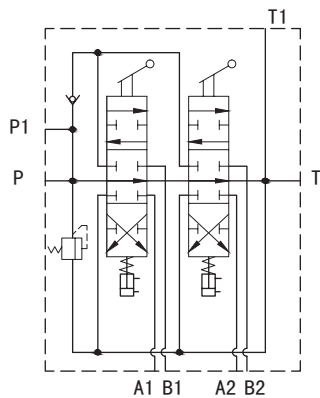

技术参数:

1. 公称压力: 16MPa,
2. 最大流量: 80L/min

注: 订货有特殊要求者, 请与销售顾问联系。

Note: Special features not listed can often be made to your specifications. Please consult your sales representative.

a61

ZT-L20气控系列多路阀 MDCV

# ZT-L20电气控系列多路阀

## ZT-L20 Electric and Pneumatic Control Valve

### 产品描述/SPECIFICATION

ZT-L20电气控制系列多路阀是在ZT-L20气控系列的基础上改进而来。它主要是改变了气控换向阀的操纵机构，在气控的基础上增加了电气控制，并且可以根据客户需求，安装无线遥控，能够更好地实现远程控制。该阀广泛应用于工程机械、环卫机械、矿山机械和其他机械的液压系统。

### 产品特点/FEATURES

- ◆ 内置单向阀：阀体内置单向阀，防止油液倒流
- ◆ 内置安全阀：阀体内置溢流阀，可调节控制系统压力
- ◆ 油路形式：并联油路，带压力输出口
- ◆ 控制方式：气控换向，也可手动换向
- ◆ 阀体结构：整体结构，1-5联任意组合
- ◆ 阀杆机能：O、A、Y等
- ◆ Inner check valve: The check valve inside the valve body to insure the hydraulic oil not to be returned.
- ◆ Inner relief valve: The relief valve inside the valve body is able to adjust the hydraulic system working pressure.
- ◆ Oil way: Parallel circuit, with power beyond.
- ◆ Control Way: electric and pneumatic control, manual control
- ◆ Valve construction: monoblock construction, 1-5 levers are available to be assembled as you requests.
- ◆ Spool Function: O,A,Y etc.

### 型号说明/MODEL CODE

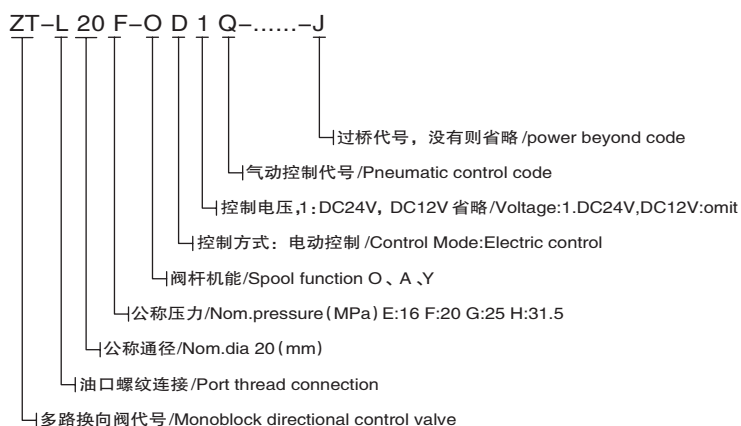

### 性能参数/SPECIFICATIONS

公称压力 (MPa) Nom. Pressure	最大压力 (MPa) Max. Pressure	公称流量 (L/min) Nom. Flow rate	最大流量 (L/min) Max. Flow rate	中位背压 (MPa) Back Pressure	工作油液hydraulic oil		
					温度范围 (°C) Tem.rang	粘度范围 (mm <sup>2</sup> /S) Visc.rang	过滤精度 (μm) filtrating accuracy
20	31.5	80	100	≤1	-20 ~ +80	10 ~ 400	≤10

# ZT-L20电气控系列多路阀

## ZT-L20 Series Electric and Pneumatic Directional Control Valves

### ZT-L20 Electric and Pneumatic Control Valve

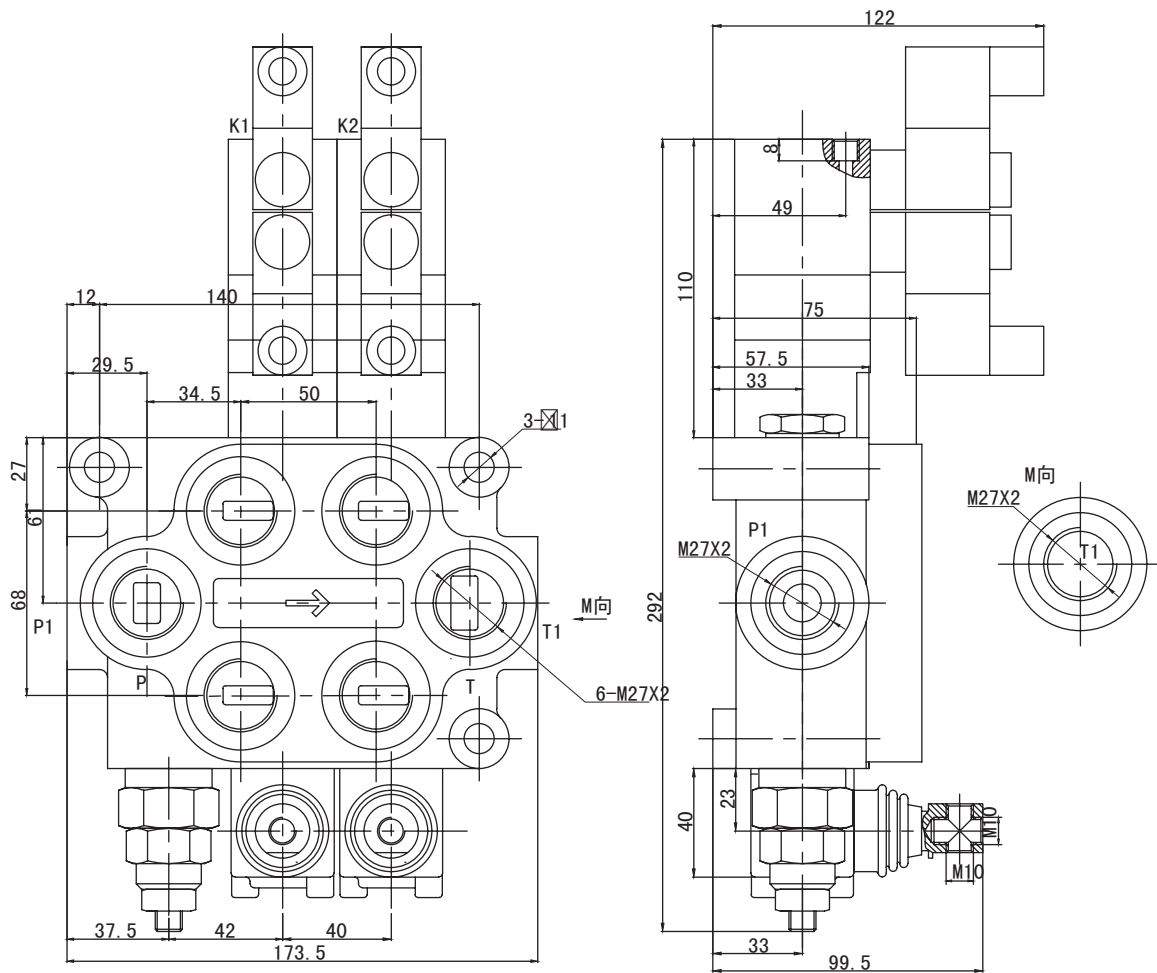

原理图

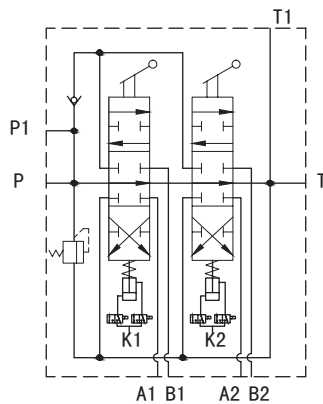

技术参数:

1. 公称压力: 16MPa,
2. 最大流量: 80L/min,
3. 控制电压DC12V/DC24V.

注: 订货有特殊要求者, 请与销售顾问联系。

Note: Special features not listed can often be made to your specifications. Please consult your sales representative.

# HS4 系列分片式多路阀

## HS4 Series Sectional Directional Control Valves

### 产品描述/SPECIFICATION

HS4系列分片式多路阀引进了欧洲先进技术，具有机构紧凑、耐高压，使用寿命长，能做1-14连，同时有中位开启和中位闭合两种液压系统。HS4每一片阀体都可以根据客户要求增加溢流阀，补油阀等。控制方式有手动、气动、电液控和软轴遥控等多种不同的控制方式，以满足客户不同的操控需求。该阀广泛应用于工程机械、环卫机械、矿山机械和其他机械的液压系统。



### 产品特点/FEATURES

- ◆ Simple, compact and heavy duty designed sectional valve from 1-14 sections for open and closed centre hydraulic systems.
- ◆ Flow rate: 90l/min, with max pressure 315bar.
- ◆ Joining port: L (screw connection)
- ◆ Spool function options: O,P, Y, A and etc.
- ◆ Nominal diameter: G1/2; G3/4, 7/8-14UNF ,SAE10, 3/4-16UNF, SAE8, M18X1.5
- ◆ Spring side control options: spring control and detent control
- ◆ Lever side control options: manual, pneumatic control, electric and pneumatic control, hydraulic and electric control, hydraulic control and remote control.

### 型号说明/MODEL CODE

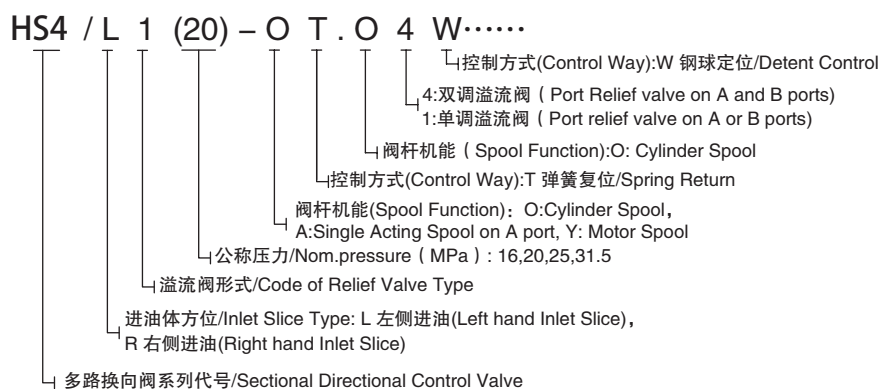

### 技术参数/PARAMETERS

公称压力 ( MPa ) Nom. Pressure	最大压力 ( MPa ) Max. Pressure	公称流量 ( L/min ) Nom. Flow rate	中位背压 ( MPa ) Back Pressure	工作油液 hydraulic oil		
				温度范围 ( °C ) Tem.rang	粘度范围 ( mm2/S ) Visc.rang	过滤精度 ( μ m ) filtrating accuracy
16	31.5	80	≤1	-20 ~ +80	10 ~ 400	≤10

# HS4系列分片式多路阀

## HS4 Series Sectional Directional Control Valves

### HS4 外形安装连接尺寸/MODEL HS4 DIMENSIONAL DATA

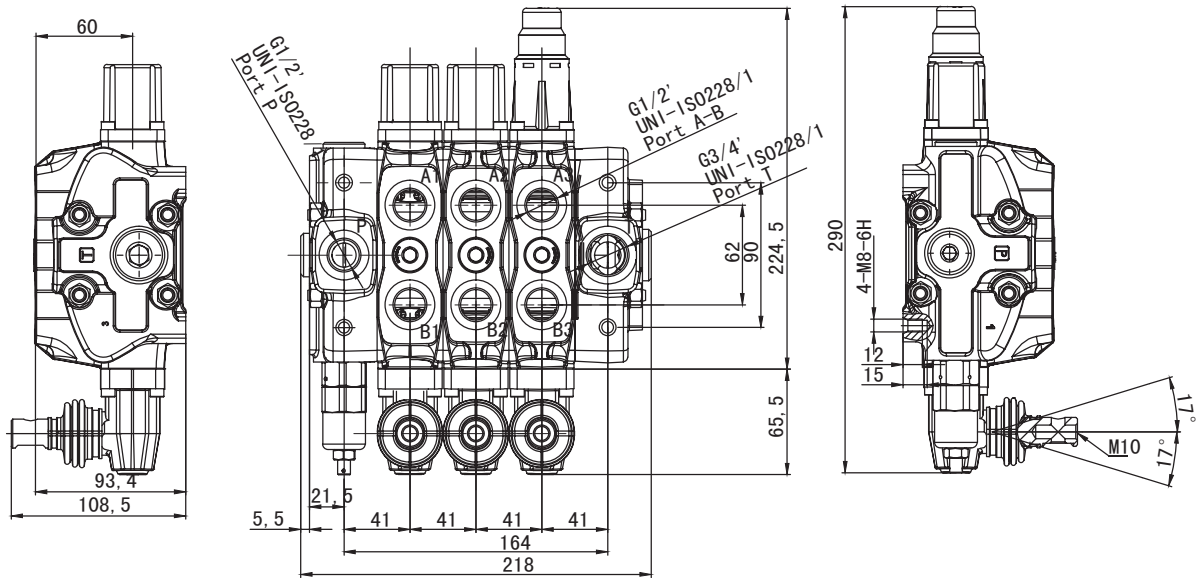

HYDRAULIC CIRCUIT

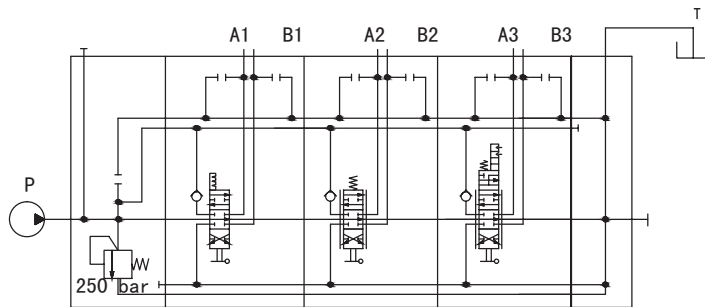

注：订货有特殊要求者，请与销售顾问联系。

Note: Special features not listed can often be made to your specifications. Please consult your sales representative.

b2

HS4系列分片式多路阀SDCV

# HS4系列液控多路阀

## HS4 Hydraulic Pilot Control Valve

### 产品描述/SPECIFICATION

HS4系列分片式多路阀引进了欧洲先进技术，具体有机构紧凑、耐高压，使用寿命长。HS4每一片阀体都可以根据客户要求增加溢流阀，补油阀等。控制方式有手动、气动、电液控和软轴遥控等多种不同的控制方式，以满足客户不同的操控需求。该阀广泛应用于工程机械、环卫机械、矿山机械和其他机械的液压系统。



### 产品特点/FEATURES

- ◆ Simple, compact and heavy duty designed sectional valve from 1 to 14 sections for open and closed center hydraulic systems.
- ◆ Fitted with a main pressure relief valve and a load check valve on every working section
- ◆ Flow rate:90LPM, with max pressure 315bar.
- ◆ Spool function options: P,T,Y,A and ect.
- ◆ Optional carry-over port.
- ◆ A wide range of anti shock+anticavitation port valves.
- ◆ Intermediate sections for several types of circuit.
- ◆ Available manual, pneumatic, electrohydraulic, proportional hydraulic, spool control kits.
- ◆ Diameter 18 mm (0.71 in) interchangeable spools.

### 型号说明/MODEL CODE

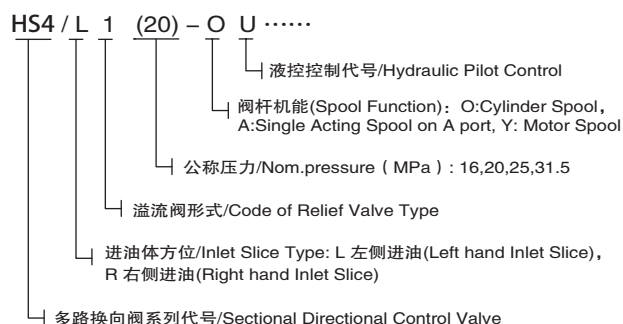

### 技术参数/PARAMETERS

公称压力 ( MPa ) Nom. Pressure	最大压力 ( MPa ) Max. Pressure	公称流量 ( L/min ) Nom. Flow rate	中位背压 ( MPa ) Back Pressure	工作油液 hydraulic oil		
				温度范围 ( °C ) Tem.rang	粘度范围 ( mm2/S ) Visc.rang	过滤精度 ( μ m ) filtrating accuracy
16	31.5	80	≤1	-20 ~ +80	10 ~ 400	≤10

# HS4系列液控多路阀

## HS4 Hydraulic Pilot Control Valve

### 技术参数/PARAMETERS

油口 MAIN PORTS	英制 BSP	美制 UN-UNF
进油口 Inlet P	G1/2	7/8-14UNF (SAE 10)
工作油口 Ports A and B	G1/2	3/4-16UNF(SAE8)
出油口 Outlet T	G3/4	7/8-14UNF (SAE 10)
高压输出口 carry-over C	G3/4	7/8-14UNF (SAE 10)
液控油口 Hydraulic pilot port	G1/4	9/16-18(SAE6)

注：订货有特殊要求者，请与销售顾问联系。

Note: Special features not listed can often be made to your specifications. Please consult your sales representative.

### HS4外形安装连接尺寸/MODELR DV HS4 DIMENSIONAL DATA

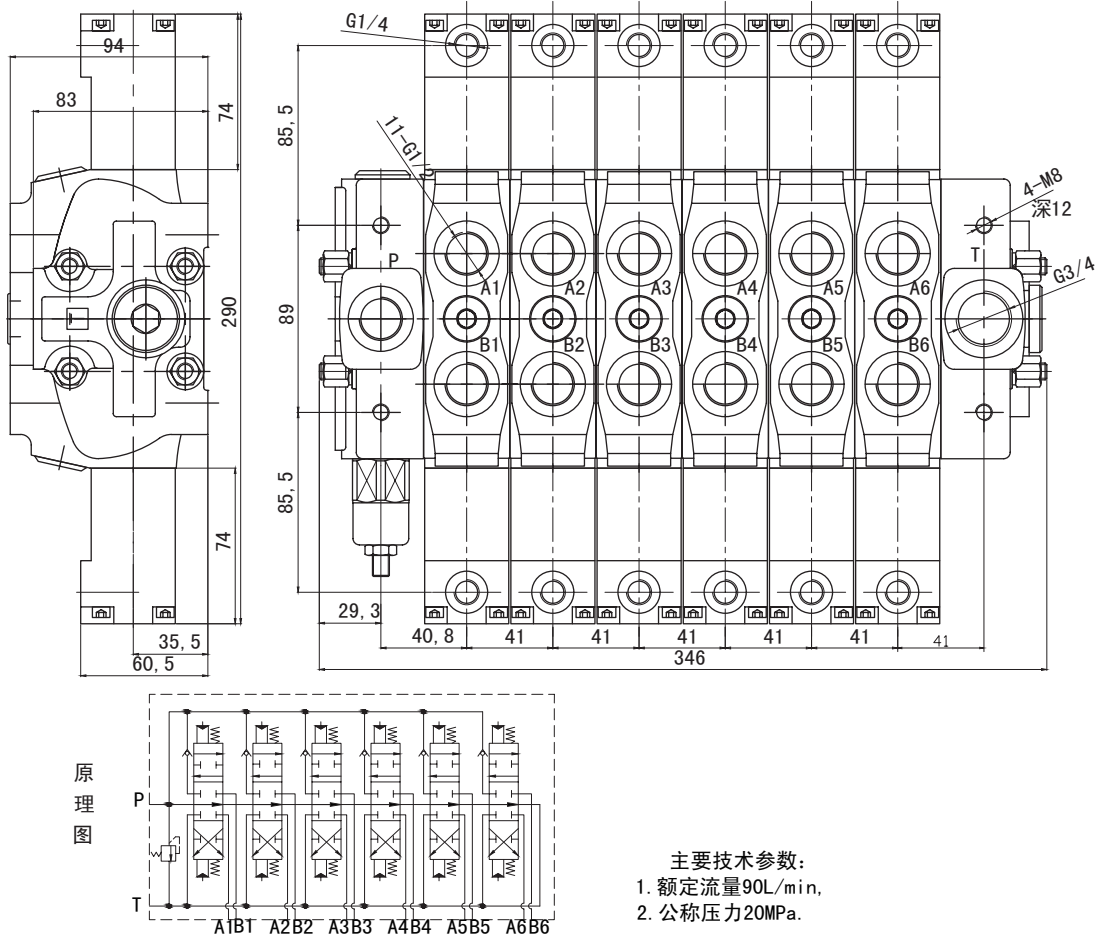

- 主要技术参数:
1. 额定流量90L/min,
  2. 公称压力20MPa.

# HS8系列分片式多路阀

## HS8 Series Sectional Directional Control Valves

### 产品描述/SPECIFICATION

HS8系列分片式多路阀引进了欧洲先进技术，具有机构紧凑、耐高压，使用寿命长。HS8每一片阀体都可以根据客户要求增加溢流阀，补油阀等。控制方式有手动、气动、电液控和软轴遥控等多种不同的控制方式，以满足客户不同的操控需求。该阀广泛应用于工程机械、环卫机械、矿山机械和其他机械的液压系统。



### 产品特点/FEATURES

- ◆ Simple, compact and heavy duty designed sectional valve from 1 to 12 sections for open and closed centre hydraulic systems.
- ◆ Fitted with a main pressure relief valve and a load check valve on every working section
- ◆ Available with parallel, tandem or series circuit.
- ◆ Optional carry-over port.
- ◆ A wide range of antishock+anticavitation port valves.
- ◆ Intermediate sections for several types of circuit.
- ◆ Available manual, pneumatic, electrohydraulic, proportional hydraulic, spool control kits.
- ◆ Diameter 20 mm (0.79 in) interchangeable spools.

### 型号说明/MODEL CODE

HS8 / L 1 (20) – A T . O 4 W.....

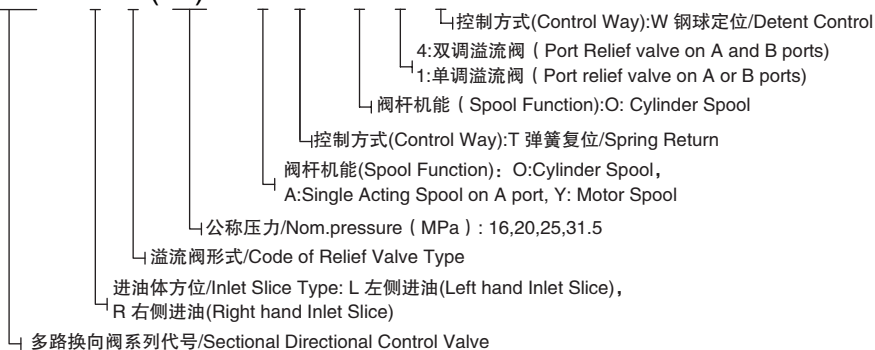

### 技术参数/PARAMETERS

公称压力 (MPa) Nom. Pressure	最大压力 (MPa) Max. Pressure	公称流量 (L/min) Nom. Flow rate	中位背压 (MPa) Back Pressure	工作油液 hydraulic oil		
				温度范围 (℃) Tem.rang	粘度范围 (mm <sup>2</sup> /S) Visc.rang	过滤精度 (μm) filtrating accuracy
16	31.5	160	≤1	-20 ~ +80	10 ~ 400	≤10

# HS8系列分片式多路阀

## HS8 Series Sectional Directional Control Valves

### HS8外形安装连接尺寸/MODEL HS8 DIMENSIONAL DATA

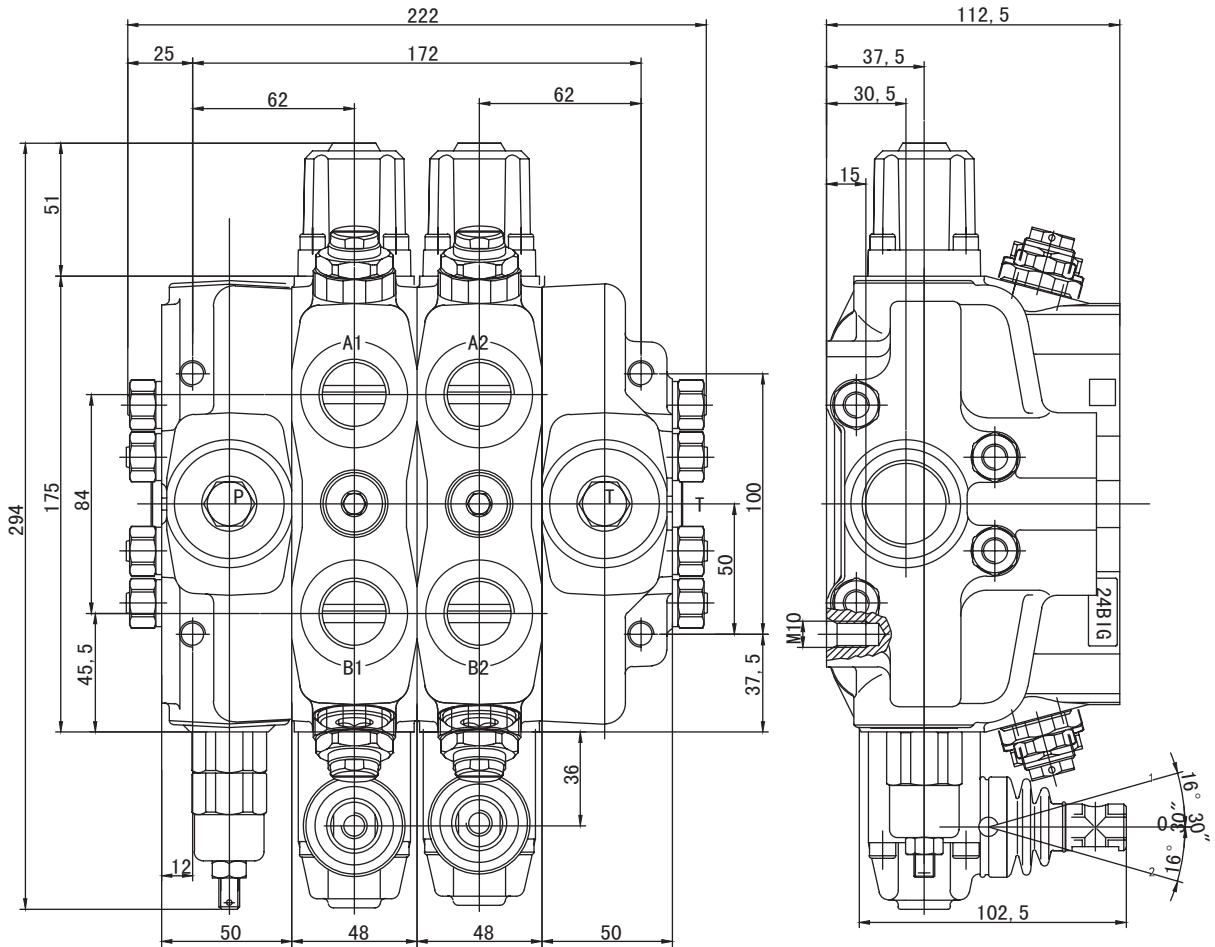

HYDRAULIC CIRCUIT

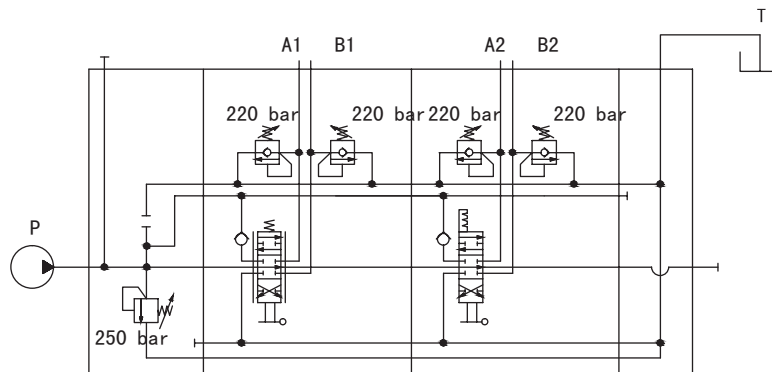

注：订货有特殊要求者，请与销售顾问联系。

Note: Special features not listed can often be made to your specifications. Please consult your sales representative.

b6

HS8系列分片式多路阀SDCV

# HS8系列液控分片式多路阀

## HS8 Hydraulic Pilot Control Valve

### 用途与特征/APPLICATIONS&FEATURES

HS8系列分片式多路阀引进了欧洲先进技术，具体有机构紧凑、耐高压，使用寿命长。HS8每一片阀体都可以根据客户要求增加溢流阀，补油阀等。控制方式有手动、气动、电液控和软轴遥控等多种不同的控制方式，以满足客户不同的操控需求。该阀广泛应用于工程机械、环卫机械、矿山机械和其他机械的液压系统。



### 产品特点/FEATURES

Simple, compact and heavy duty designed sectional valve from 1 to 12 sections for open and closed center hydraulic systems.

- ◆ Fitted with a main pressure relief valve and a load check valve on every working section
- ◆ Available with parallel, tandem or series circuit.
- ◆ Optional carry-over port.
- ◆ A wide range of antishock+anticavitation port valves.
- ◆ Intermediate sections for several types of circuit.
- ◆ Available manual, pneumatic, electrohydraulic, proportional hydraulic, spool control kits.
- ◆ Diameter 20 mm (0.79 in) interchangeable spools.

### 型号说明/MODEL CODE

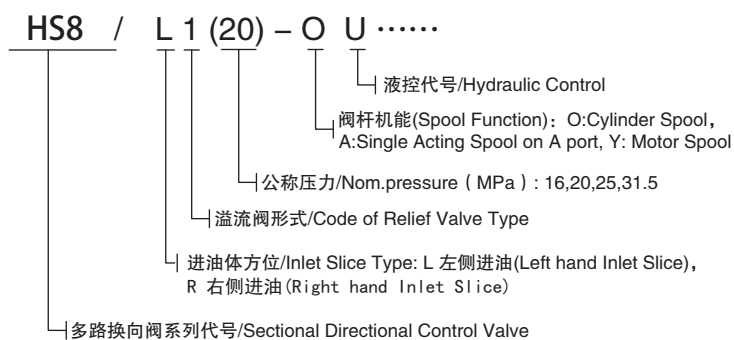

### 技术参数/PARAMETERS

公称压力 (MPa) Nom. Pressure	最大压力 (MPa) Max. Pressure	公称流量 (L/min) Nom. Flow rate	中位背压 (MPa) Back Pressure	工作油液hydraulic oil		
				温度范围 (℃) Tem.rang	粘度范围 (mm <sup>2</sup> /S) Visc.rang	过滤精度 (μm) filtrating accuracy
16	31.5	160	≤1	-20 ~ +80	10 ~ 400	≤10

# HS8系列液控分片式多路阀

## HS8 Hydraulic Pilot Control Valve

### 油口尺寸/PORT SIZE

油口 MAIN PORTS	英制 BSP	美制 UN-UNF
进油口 Inlet P	G3/4	1 5/16-12 UN-2B (SAE 16)
工作油口 Ports A and B	G3/4	1 1/16-12 UN-2B (SAE 12)
出油口 Outlet T	G1	1 5/16-12 UN-2B (SAE 16)
高压输出口 carry-over C	G1	1 5/16-12 UN-2B (SAE 16)
液控油口 Hydraulic pilot port	G1/4	9/16-18(SAE6)

注：订货有特殊要求者，请与销售顾问联系。

Note: Special features not listed can often be made to your specifications. Please consult your sales representative.

### HS8外形安装连接尺寸/MODEL HS8 DIMENSIONAL DATA

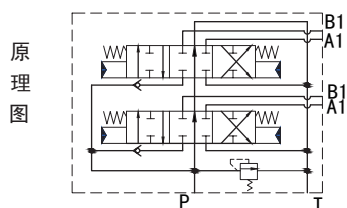
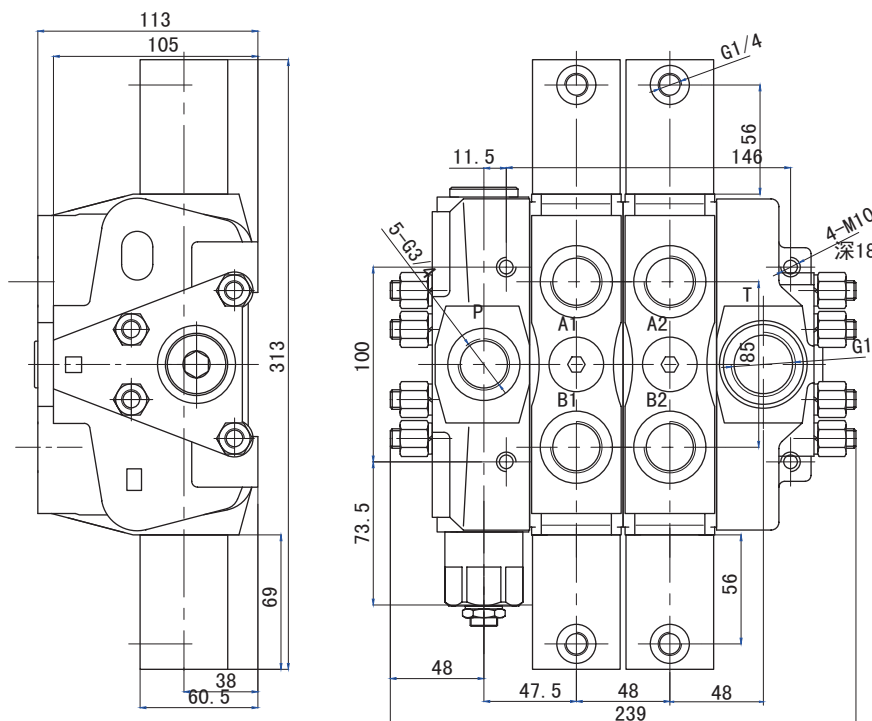

#### 主要技术参数:

1. 额定流量160L/min
2. 公称压力20MPa.

b8

HS8系列液控分片式多路阀 SDCV

# HS9系列分片式多路阀

## HS9 Series Sectional Directional Control Valves

### 产品描述/SPECIFICATION

HS9系列分片式多路阀引进了欧洲先进技术，具有机构紧凑、耐高压，使用寿命长。同时HS9片阀的流量高达240l/min，能满足大型工程机械的设计流量要求。HS9每一片阀体都可以根据客户要求增加溢流阀，补油阀等。控制方式有手动、气动、电液控和软轴遥控等多种不同的控制方式，以满足客户不同的操控需求。该阀广泛应用于工程机械、环卫机械、矿山机械和其他机械的液压系统。



### 产品特点/FEATURES

- ◆ Simple, compact and heavy duty designed sectional valve from 1 to 12 sections for open and closed centre hydraulic systems.
- ◆ Fitted with a main pressure relief valve and a load check valve on every working section
- ◆ Available with parallel or series circuit.
- ◆ Optional carry-over port.
- ◆ A wide variety of service ports and circuit valves.
- ◆ Available manual, pneumatic, hydraulic, electro-hydraulic, and remote with flexible cables spool control kits.
- ◆ Diameter 25 mm (0.98 in) interchangeable spools.

### 型号说明/MODEL CODE

HS9 / L 1 (20) - A T . O 4 W.....

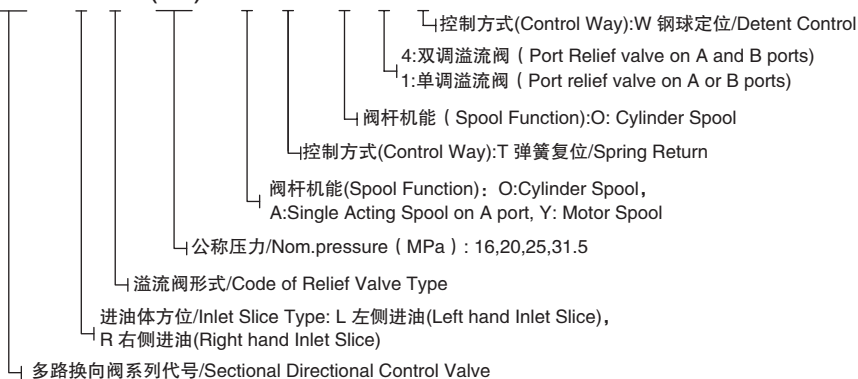

### 技术参数/PARAMETERS

公称压力 (MPa) Nom. Pressure	最大压力 (MPa) Max. Pressure	公称流量 (L/min) Nom. Flow rate	中位背压 (MPa) Back Pressure	工作油液 hydraulic oil		
				温度范围 (℃) Tem.rang	粘度范围 (mm <sup>2</sup> /S) Visc.rang	过滤精度 (μm) filtrating accuracy
16	31.5	240	≤1	-20 ~ +80	10 ~ 400	≤10

# HS9系列分片式多路阀

## HS9 Series Sectional Directional Control Valves

### HS9 外形安装连接尺寸/MODEL HS9 DIMENSIONAL DATA

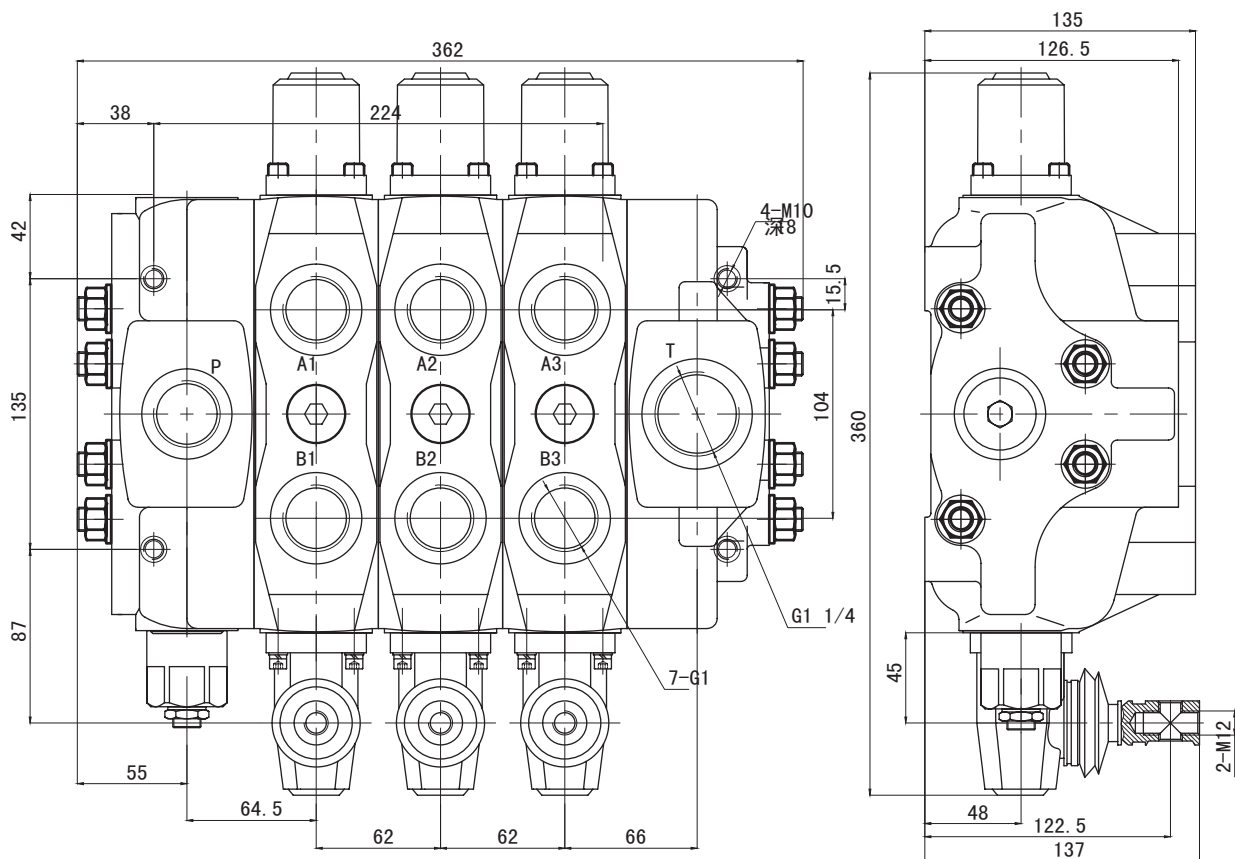

原理图

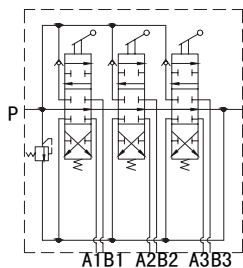

主要技术参数:

1. 额定流量240L/min,
2. 公称压力20MPa.

注: 订货有特殊要求者, 请与销售顾问联系。

Note: Special features not listed can often be made to your specifications. Please consult your sales representative.

b10

HS9系列分片式多路阀SDCV

# HS9系列液控多路阀

## HS9 Hydraulic Pilot Control Valve

### 用途与特征/APPLICATIONS&FEATURES

HS9系列分片式多路阀引进了欧洲先进技术，具体有机构紧凑、耐高压，使用寿命长。同时HS9片阀的流量高达240l/min，能满足大型工程机械的设计流量要求。HS9每一片阀体都可以根据客户要求增加溢流阀，补油阀等。控制方式有手动、气动、电液控和软轴遥控等多种不同的控制方式，以满足客户不同的操控需求。该阀广泛应用于工程机械、环卫机械、矿山机械和其他机械的液压系统。

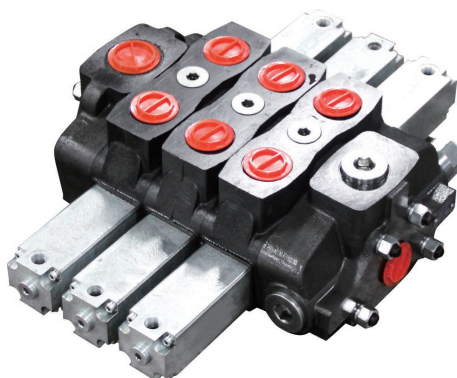

### 产品特点/FEATURES

- ◆ Simple, compact and heavy duty designed sectional valve from 1 to 12 sections for open and closed center hydraulic systems.
- ◆ Fitted with a main pressure relief valve and a load check valve on every working section
- ◆ Available with parallel or series circuit.
- ◆ Optional carry--over port.
- ◆ A wide variety of service ports and circuit valves.
- ◆ Available manual, pneumatic, hydraulic, electro--hydraulic, and remote with flexible cables spool control kits.
- ◆ Diameter 25 mm (0.98 in) interchangeable spools.

### 型号说明/MODEL CODE

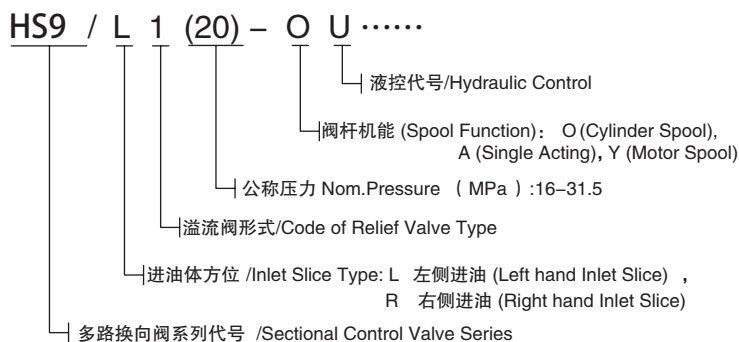

### 技术参数/PARAMETERS

公称压力 ( MPa ) Nom. Pressure	最大压力 ( MPa ) Max. Pressure	公称流量 ( L/min ) Nom. Flow rate	中位背压 ( MPa ) Back Pressure	工作油液hydraulic oil		
				温度范围 ( °C ) Tem.rang	粘度范围 ( mm2/S ) Visc.rang	过滤精度 ( μ m ) filtrating accuracy
16	31.5	240	≤1	-20 ~ +80	10 ~ 400	≤10

# HS9系列液控多路阀

## HS9 Hydraulic Pilot Control Valve

### 油口尺寸/PORT SIZE

油口 MAIN PORTS	英制 BSP	美制 UN-UNF
进油口 Inlet P	G1	1 5/8-12 UN-2B (SAE 20)
工作油口 Ports A and B	G1	1 5/16-12 UN-2B (SAE 16)
出油口 Outlet T	G1 1/4	1 5/8-12 UN-2B (SAE 20)
高压输出口 carry-over C	G1 1/4	1 5/8-12 UN-2B (SAE 20)
液控油口 Hydraulic Pilot Port	G 1/4	9/16-18 UNF-2B (SAE 6)

### HS9外形安装连接尺寸/MODEL HS9 DIMENSIONAL DATA

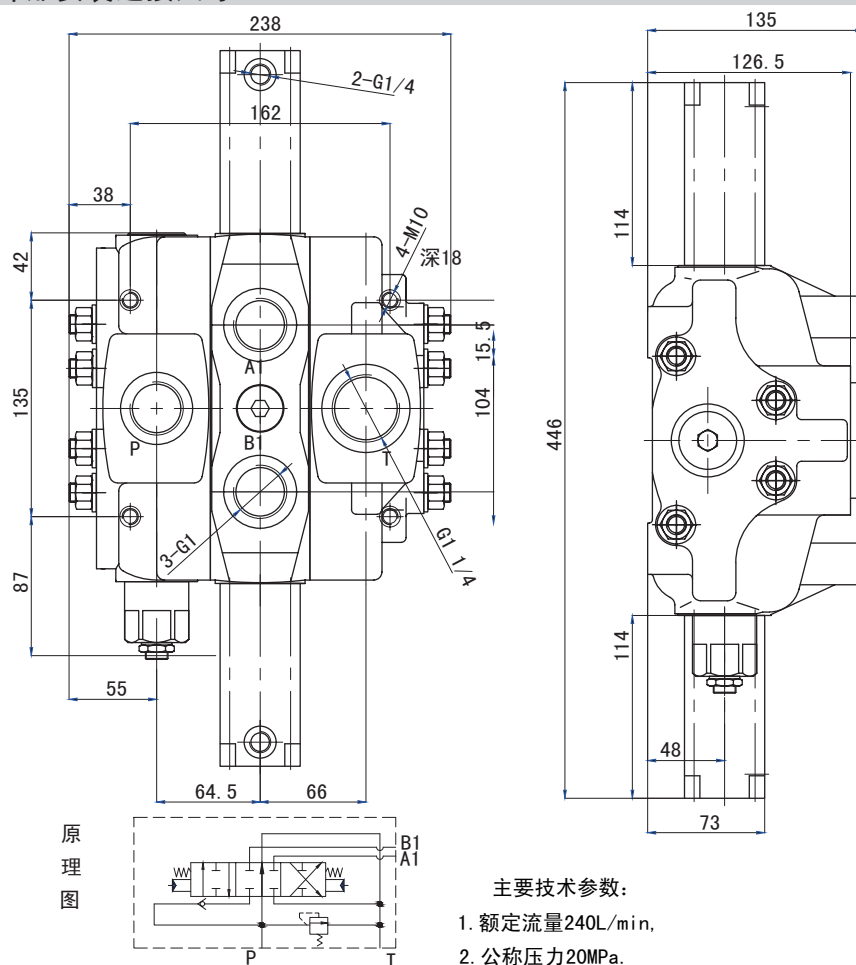

#### 主要技术参数:

1. 额定流量240L/min,
2. 公称压力20MPa.

注: 订货有特殊要求者, 请与销售顾问联系。

Note: Special features not listed can often be made to your specifications. Please consult your sales representative.

b12

HS9系列液控多路阀SDCV

# HS10系列分片式多路阀

## HS10Series Sectional Directional Control Valves

### 产品描述/SPECIFICATION

HS10系列分片式多路阀引进了欧洲先进技术，具有机构紧凑、耐高压，使用寿命长。流量高达400l/min，填补了国内大流量多路阀的空白。HS10每一片阀体都可以根据客户要求增加溢流阀，补油阀等。控制方式有手动、气动、电液控和软轴遥控等多种不同的控制方式，以满足客户不同的操控需求。该阀广泛应用于工程机械、环卫机械、矿山机械和其他机械的液压系统。

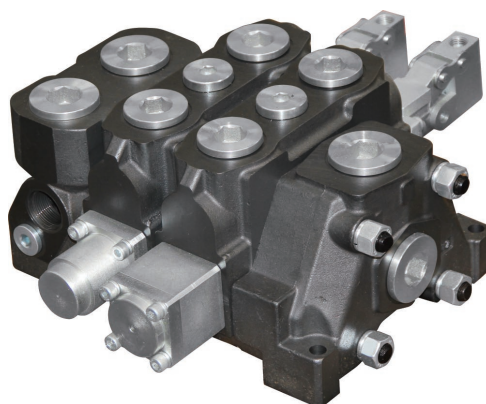

### 产品特点/FEATURES

- ◆ Sectional directional control valve for high flow, available for fixed displacements hydraulic pumps.
- ◆ From 1 to 10 work sections
- ◆ Open centre
- ◆ Optional carry-over port
- ◆ Main pilot relief valve on inlet cover and load check valve on every section
- ◆ Available wide range of port valves Available manual and hydraulic control kits
- ◆ Diameter 30 mm (1.18 in) interchangeable spools

### 型号说明/MODEL CODE

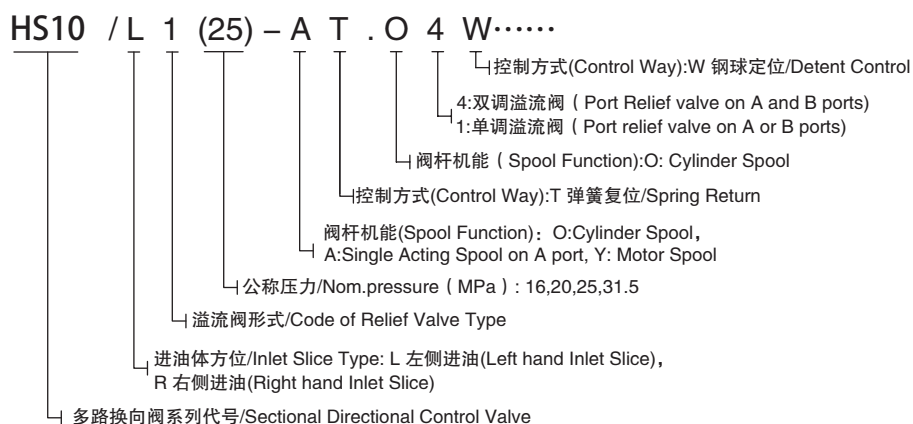

### 技术参数/PARAMETERS

公称压力 (MPa) Nom. Pressure	最大压力 (MPa) Max. Pressure	公称流量 (L/min) Nom. Flow rate	中位背压 (MPa) Back Pressure	工作油液hydraulic oil		
				温度范围 (℃) Tem.rang	粘度范围 (mm <sup>2</sup> /S) Visc.rang	过滤精度 (μm) filtrating accuracy
16	31.5	400	≤1	-20 ~ +80	10 ~ 400	≤10

# HS10系列分片式多路阀

## HS10 Series Sectional Directional Control Valves

### HS10 外形安装连接尺寸/MODEL HS10 DIMENSIONAL DATA

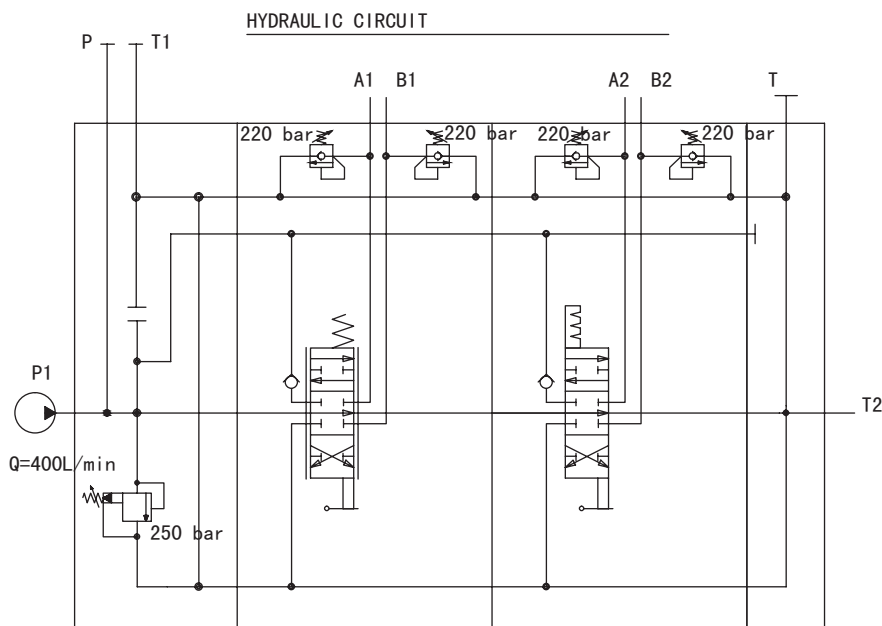
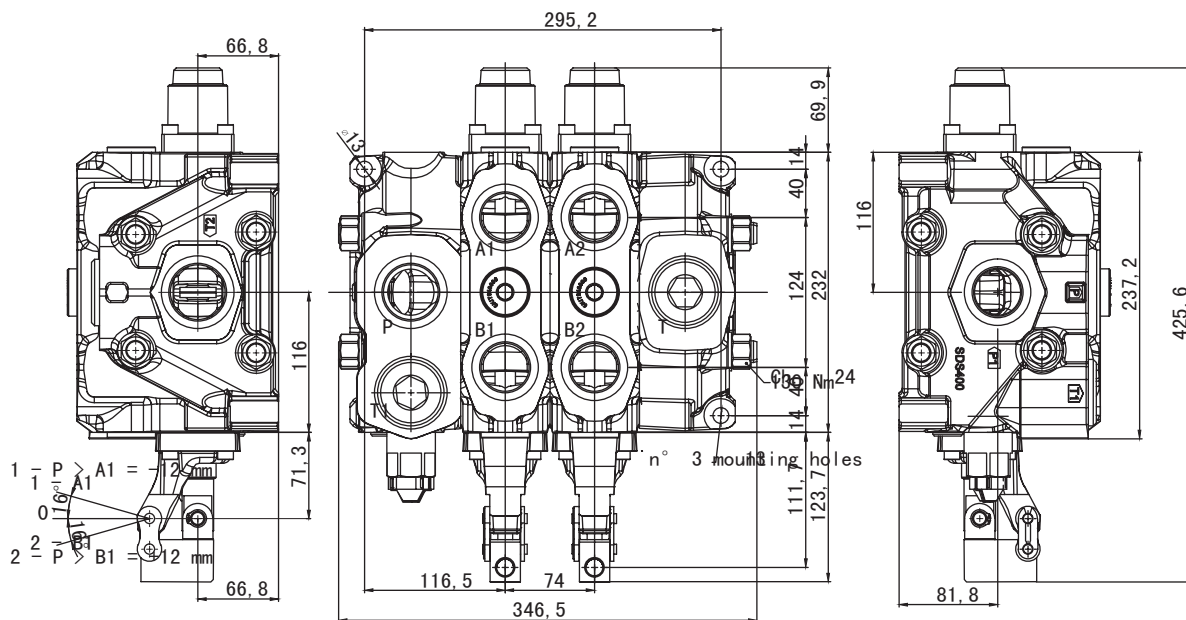

注：订货有特殊要求者，请与销售顾问联系。

Note: Special features not listed can often be made to your specifications. Please consult your sales representative.

b14

HS10系列分片式多路阀SDCV

# HS10系列液控片式多路阀

## HS10 Hydraulic Pilot Control Valve

### 用途与特征/APPLICATIONS&FEATURES

HS10系列分片式多路阀引进了欧洲先进技术，具体有机构紧凑、耐高压，使用寿命长。流量高达400l/min，填补了国内大流量多路阀的空白。HS10每一片阀体都可以根据客户要求增加溢流阀，补油阀等。控制方式有手动、气动、电液控和软轴遥控等多种不同的控制方式，以满足客户不同的操控需求。该阀广泛应用于工程机械、环卫机械、矿山机械和其他机械的液压系统。

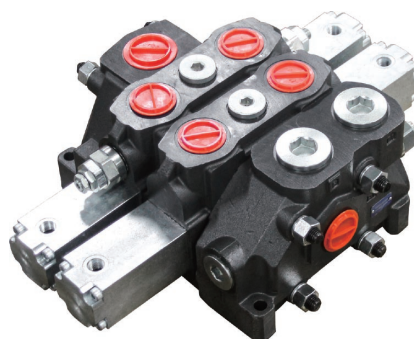

### 产品特点/FEATURES

- ◆ Sectional directional control valve for high flow, available for fixed displacements hydraulic pumps.
- ◆ From 1 to 10 work sections
- ◆ Open center
- ◆ Optional carry-over port
- ◆ Main pilot relief valve on inlet cover and load check valve on every section
- ◆ Available wide range of port valves Available manual and hydraulic control kits
- ◆ Diameter 30 mm (1.18 in) interchangeable spools

### 型号说明/MODEL CODE

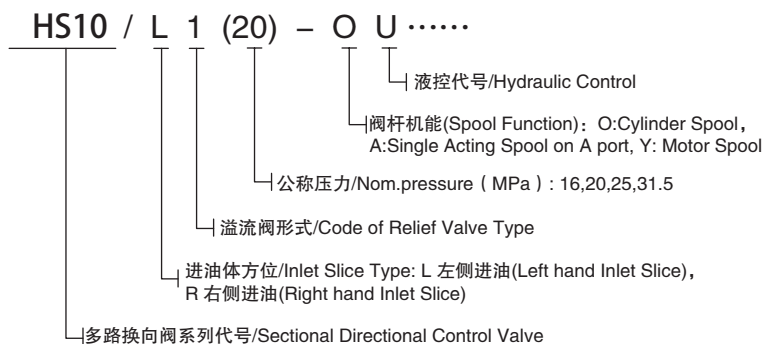

### 技术参数/PARAMETERS

公称压力 (MPa) Nom. Pressure	最大压力 (MPa) Max. Pressure	公称流量 (L/min) Nom. Flow rate	中位背压 (MPa) Back Pressure	工作油液hydraulic oil		
				温度范围 (℃) Tem.rang	粘度范围 (mm <sup>2</sup> /S) Visc.rang	过滤精度 (μm) filtrating accuracy
16	31.5	400	≤1	-20 ~ +80	10 ~ 400	≤10

# HS10系列液控片式多路阀

## HS10 Hydraulic Pilot Control Valve

### 油口尺寸/PORT SIZE

油口 MAIN PORTS	英制 BSP	美制 UN-UNF
进油口 Inlet P/P1	G1 1/2 / G1 1/4	1 7/8-12 (SAE 24) 1 5/8-12 (SAE 20)
工作油口 Ports A and B	G1 1/4	1 5/8-12 (SAE 20)
出油口 Outlet T	G1 1/4	1 7/8-12 (SAE 24)
高压输出口 carry-over C	G1 1/2	1 7/8-12 (SAE 24)
液控油口 Hydraulic pilot port	G3/8	9/16-18 (SAE8)

注：订货有特殊要求者，请与销售顾问联系。

Note: Special features not listed can often be made to your specifications. Please consult your sales representative.

### HS10 外形安装连接尺寸/MODEL HS10 DIMENSIONAL DATA

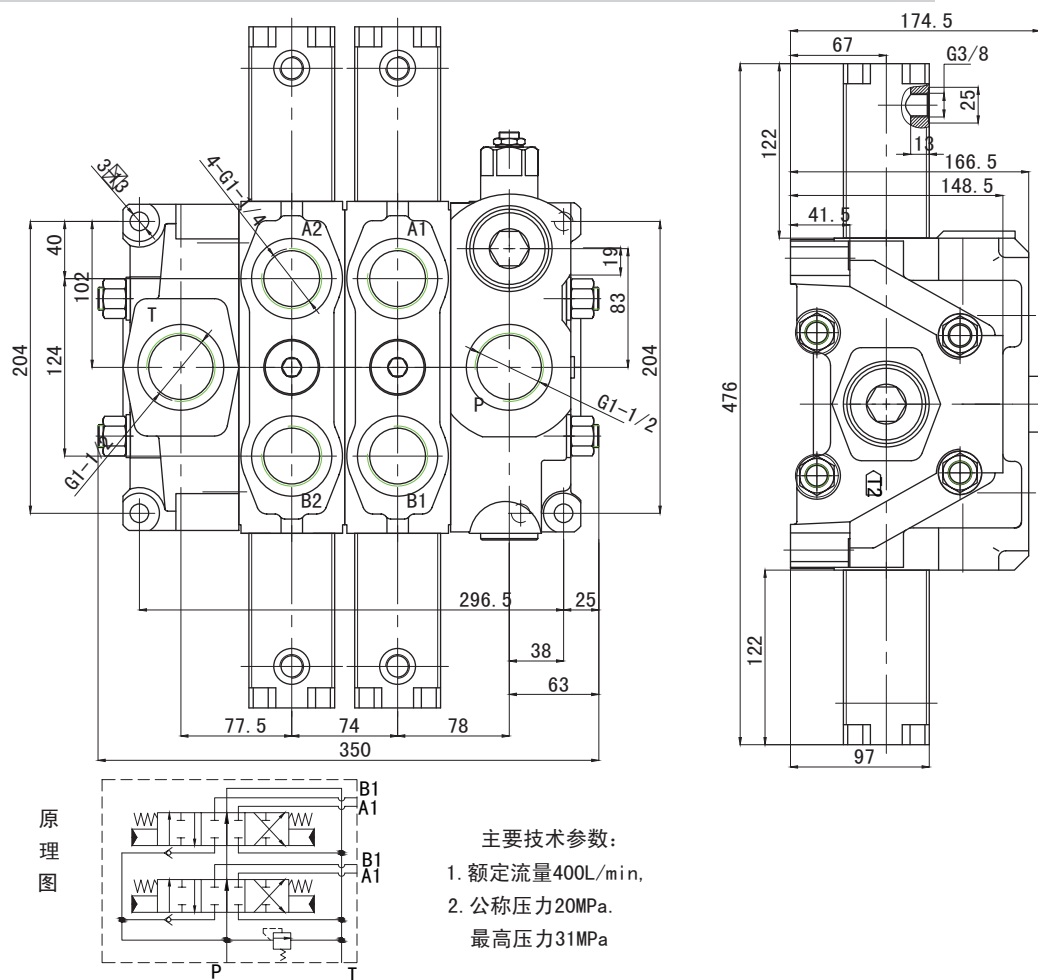

- 主要技术参数:
1. 额定流量400L/min.
  2. 公称压力20MPa.  
最高压力31MPa

b16

HS10系列液控片式多路阀SDCV

# DCV分体式多路阀如何订货 HOW TO ORDER IN DVC SECTION VALVE

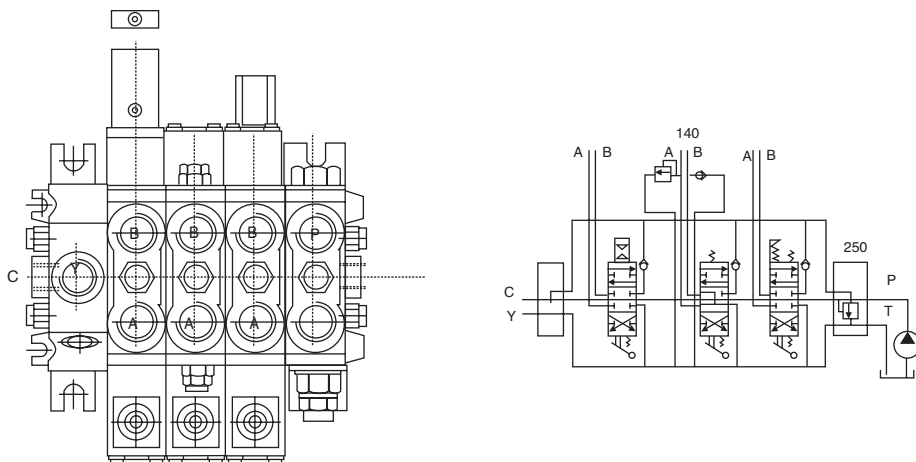

订货编号：  
Order Code Number:

DCV \*\*/\*-\*\*\*\*/\*\*\*\*\*

DCV35、DVC60  
DCV60A、DVC100  
DCV140、DVC160  
DCV200、DVC250

订货号，由胜杰公司提供专用号  
Ordering Code Number,  
offered by QTFLUID

工作片数量：1-12  
Number of wording  
sections:1-12

功能详细介绍：  
Function Presentation:

NO. 1 WORKING SECTION    NO. 2 WORKING SECTION  
第一个工作片                      第2个工作片

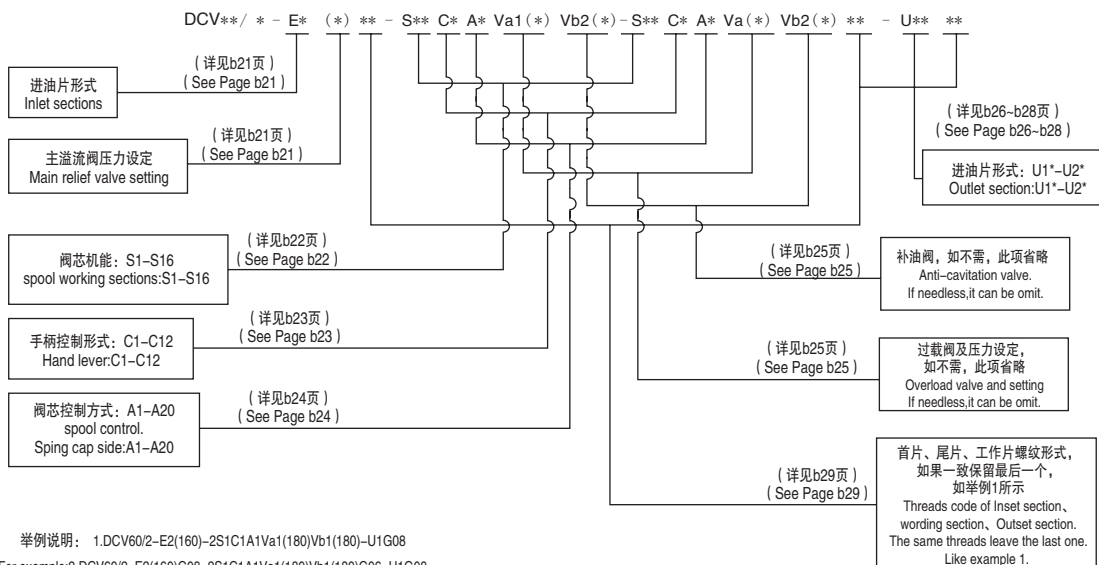

举例说明: 1.DCV60/2-E2(160)-2S1C1A1Va1(180)Vb1(180)-U1G08  
For example:2.DCV60/2-E2(160)G08-2S1C1A1Va1(180)Vb1(180)G06-U1G08

## DCV 分体式多路阀选型——进油片

## THE CHOICES OF THE DCV SECTION VALVE--INLET SECTION

DCV*/*	E**	(*)	**	S**	C*	A*	Va*	Vb*	**	U**	**
--------	-----	-----	----	-----	----	----	-----	-----	----	-----	----

### 进油片 INLET SECTION

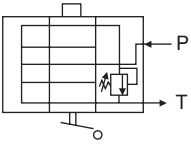
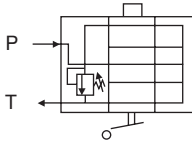
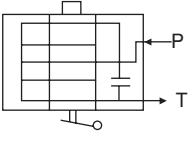
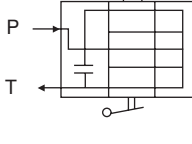
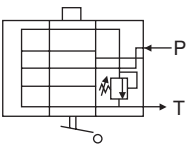
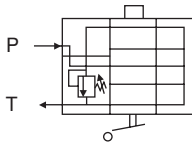
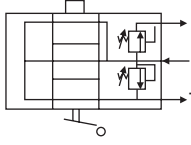
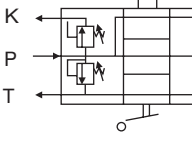
	右侧进油 (标准的) 进油口P在顶部 Right inlet section.(Standard) With top p port.	E2		左侧进油 (标准的) 进油口P在顶部 Left inlet section.(Standard) With top p port.	E7						
	右侧进油 进油口P在顶部不带主溢流阀 Right inlet section.(Standard) With top p port.Inlet section without main relief valve.	E23		左侧进油 进油口P在顶部不带主溢流阀 Left inlet section.(Standard) With top p port.Inlet section without main relief valve.	E73						
	右侧进油 进油口P在侧部 Right inlet section.(Standard) With side p port.	E24		左侧进油 进油口P在侧部 Left inlet section.(Standard) With side p port.	E74						
	右侧进油 带减压阀 进油口P在顶部 Right inlet section. With reduce valve	E25		左侧进油 带减压阀 进油口P在顶部 Left inlet section. With reduce valve	E75						
DCV*/*	E**	(*)	**	S*	C*	A*	Va*	Vb*	**	U*	**

### 主溢流阀调节压力 (单位:Bar) MAIN RELIFE VALVE SETTING (Units:Bar)

型号示例:所选阀最大流量60L/Min,进油方式为标准的右侧进油,选择主溢流阀压力210Bar,则型号为DCV60/\*-E7 (210)-……,如无特殊要求,请按照右表中出厂设定压力来选择所需压力。

ORDER CODE:DCV60/\*-E7 (210) -……

1).DCV60:DCV60 series,MAX FLOW:60L/MIN

2).E7:Inlet section(standard)

3).210:Main relief valves setting pressure

If you don't have any special requiriements, Choose setting pressure as we list in the table.

产品型号 Code	DCV60、100、140、160、200			
调压等级 Pressure Grade	A	B	C	D
调压范围 Pressure Range	30~180	100~240	125~265	175~320
出厂设定压力 Standard Setting Pressure	160	200	240	300

b18

DCV系列分体式多路阀如何订货及相关说明

# DCV 分体式多路阀选型——阀芯机能

## THE CHOICES OF THE DCV SECTION VALVE--WORKINGSECTION SPOOLS

DCV*/*	E**	(*)	**	S**	C*	A*	Va*	Vb*	**	U**	**
				S1							
				S2							
				S3							
				S4							
				S5							
				S6							
				S7							
				S8							
				S9							

b19

DCV系列分体式多路阀如何订货及相关说明

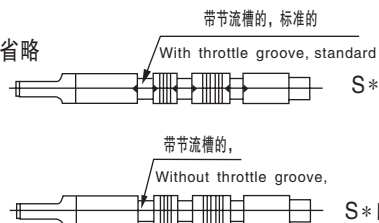

S \* H

"H"代表阀芯不带节流槽，为非标供货形式，否则省略  
Spools without throttle groove, write "H". this one is nonstandard, if not you should write nothing here  
阀芯机能，见上表  
Working section spools, see the table above

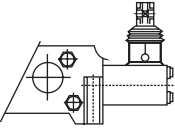
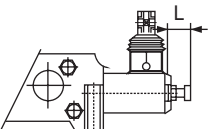
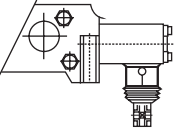
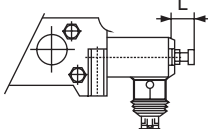
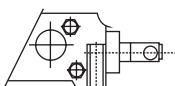

## DCV 分体式多路阀选型——阀芯前端操纵选择

## THE CHOICES OF THE DCV SECTION VALVE--SPOOL CONTROL HANDLE SIDE

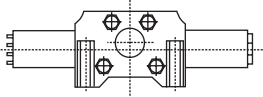
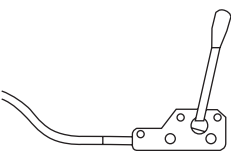
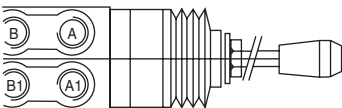
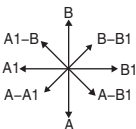
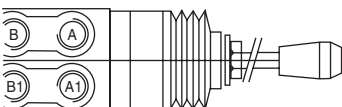
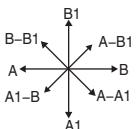
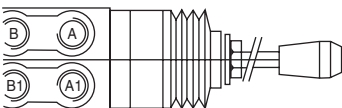
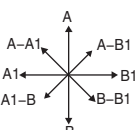
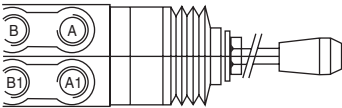
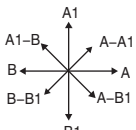
DCV*/*	E**	(*)	**	S**	C*	A*	Va*	Vb*	**	U**	**	
			标准 Standard	C1							阀芯行程调节 Spool stroke adjustment. DCV35:L=26 DCV60:L=27 DCV100、140:L=31 DCV200:L=33	C5
			手柄旋转180° 安装 Handle at 180°	C2							阀芯行程可调, 手柄旋转180° 安装 Spool stroke adjustment. Handle at 180° DCV35:L=26 DCV60:L=27 DCV100、140:L=31 DCV200:L=33	C6
			无控制杆 Without handle.	C3							安全手柄锁在中位 Safety handle locked in neutral position. 安全手柄锁在A位 Safety handle locked in position A. 安全手柄锁在B位 Safety handle locked in position B. 安全手柄锁在A和B位 Safety handle locked in position A and B. 安全手柄锁在第四位 Safety handle locked in 4th position.	C7/a C7/b C7/c C7/d C7/e
			液控 Hydraulic control	C4							软管遥控 Flexible cable control-Contact our comm.dep.	C8
											90° 操纵支点在下游片 Cloche control at 90° with fulcrum on the downstream section.	C9
											90° 操纵支点在上游片 Cloche control at 90° with fulcrum on the upstream section.	C10
											90° 操纵支点在下游片, 手柄旋转180° 安装 Cloche control at 90° with fulcrum on the downstream section.handle at 180°	C11
											90° 操纵支点在上游片, 手柄旋转180° 安装 Cloche control at 90° with fulcrum on the upstream section.handle at 180°	C12

b20

DCV系列分体式多路阀如何订货及相关说明

## DCV 分体式多路阀选型——阀芯后端控制选择

### THE CHOICES OF THE DCV SECTION VALVE--SPOOL CONTROL SPRING CAP SIDE

DCV*/*	E**	(*)	* *	S**	C*	A*	Va*	Vb*	* *	U**	* *
	三个位置, 弹簧对中 3 positions.spring centred spool.				A1			预留的, 双侧操纵, 外螺纹连接 Prearranged for double control.			A13
	三个位置, 弹簧对中,AB定位 3 positions.spring centred spool.detent in A and B.				A2			预留的, 双侧操纵, 内螺纹连接 Prearranged for double control.			A13N
	三个位置, 弹簧对中,A定位 3 positions.spring centred spool.detent in A.				A3			三个位置, A,B,O定位,无弹簧复位。 带外螺纹连接双侧操纵。 3 positions.detent in A,B and O.Prearranged for double control.Without spring centred			A713
	三个位置, 弹簧对中,B定位 3 positions.spring centred spool.detent in B.				A4			三个位置, A,B,O定位,无弹簧复位。 带内螺纹连接双侧操纵。 3 positions.detent in A,B and O.Prearranged for double control.Without spring centred			A713N
	四个位置, 弹簧对中,第四个位置定位 4 positions.spring centred spool.detent in 4th position.				A5			气缸控制 ON-OFF pneumatic control.			A14
	四个位置, 弹簧对中,第四位置浮动 4 positions.spring centred spool.sensitive 4th position without detent.				A6			12V 电液控 Electrohydraulic control ON-OFF.Voltage 12 Volt c.c			A15
	三个位置, 弹簧对中,A,B,O定位 3 positions.spring centred spool.detent in A,Band O.				A7			24V 电液控 Electrohydraulic control ON-OFF.Voltage 24 Volt c.c			A16
	三个位置, A,B,O定位,无弹簧复位 3 positions.detent in A,B and O.Without spring centred				A7			12V 电气控制 ON-OFF eletropneumatic, 12 Volt.			A171
	两个位置 (O和B), 弹簧复位 2 positions ( O and B ),spring centred spool.				A8			24V 电气控制 ON-OFF eletropneumatic, 24 Volt.			A172
	两个位置 (O和A), 弹簧复位 2 positions ( O and A ),spring centred spool.				A9			三个位置, 弹簧对中,带各种微动开关 3 positions.spring centredspool. Several microswith applications are available.			A18
	二个位置 (O和B), 弹簧复位, B定位 2 positions ( O and B ),spring centred spool, detent in B.				A10			阀芯行程可调 Spool stroke adjustment.			A20
	二个位置, 弹簧对中,A定位 2 positions ( O and A ),spring centred spool,detent in A.				A11			油缸控制 ON-OFF hydraulic control.			A24

b21

DCV系列分体式多路阀如何订货及相关说明

## DCV 分体式多路阀选型——油口选择阀 THE CHOICES OF THE DCV SECTION VALVE

DCV*/*	E**	(*)	* *	S**	C*	A*	Va*	Vb*	* *	U**	* *
--------	-----	-----	-----	-----	----	----	-----	-----	-----	-----	-----

### 油口选择阀 SERVICE PORT VALVES

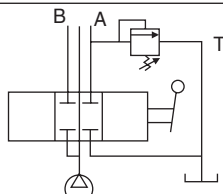
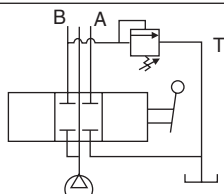
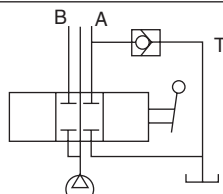
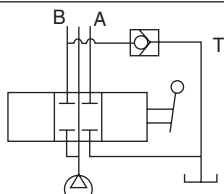
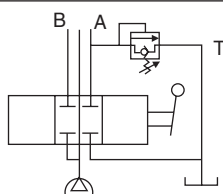
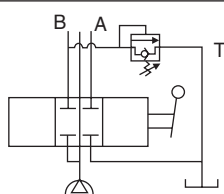
	过载阀用于A口 Overload valve in position A	Va1		过载阀用于B口 Overload valve in position B	Vb1
	补油阀用于A口 Anti-cavitation valve in position A	Va2		补油阀用于B口 Anti-cavitation valve in position B	Vb2
	复合阀用于A口 Combined valve in position A	Va3		复合阀用于B口 Combined valve in position B	Vb3

过载阀调节压力 (单位:Bar) MAIN OVERLOAD VALVE(Units:Bar)

型号示例:所选阀最大流量60L/Min,阀中第一联工作片的A、B油口均安装过载阀,压力均为180Bar,则型号为DCV60/\*-E\*(\*)-S\*C\*A\*Va1(180)Vb1(180).....如无特殊要求,请按照下表中出厂设定压力来选择所需压力。

ORDER CODE:DCV60/\*-E\*(\*)-S\*C\*A\*Va1(180)Vb1(180).....  
 1). DCV60:DCV60 series, MAX FLOW: 60L/MIN  
 2). Double 180:Overload valve in position A&B Both of the pressure are 180 Bar  
 If you don't have any special requirements, Choose setting pressure as we list in the table.

产品型号 Code	DCV60、100、140、160				DCV200			
	A	B	C	D	A	B	C	D
调压等级 Pressure Grade	A	B	C	D	A	B	C	D
调压范围 Pressure Range	30~100	80~160	140~220	200~300	30~100	90~150	140~220	200~300
出厂设定压力 Standard Pressure	80	140	200	280	60	120	200	250

b22

DCV系列分体式多路阀如何订货及相关说明

# DCV 分体式多路阀选型——出油口形式

## THE CHOICES OF THE DCV SECTION VALVE——OUTLET SECTION

DCV*//*	E**	(*)	* *	S**	C*	A*	Va*	Vb*	* *	U**	* *
---------	-----	-----	-----	-----	----	----	-----	-----	-----	-----	-----

### DCV35/60/60A/100出油片OUTLET SECTION

	出油片在左侧,T口(在首片顶部)为出油口 Left outlet section,T is the exit port, on top of inset section	出油片在右侧,T口(在首片顶部)为出油口 Right outlet section,T is the exit port, on top of inset section	U1	D口没有, C口堵塞
	出油片在左侧,C口(在尾片侧面)为出油口 Left outlet section,C is the exit port, and on side of outset section	出油片在右侧,C口(在尾片侧面)为出油口 Right outlet section,C is the exit port, and on side of outset section	U12	T口没有, D口堵塞
	出油片在左侧,D口(在尾片顶部)为出油口 Left outlet section,D is the exit port, and on top of outset section	出油片在右侧,D口(在尾片顶部)为出油口 Right outlet section,D is the exit port, and on top of outset section	U13	T、C口堵塞
	出油片在左侧,两个出油口, T口和C口 Left outlet section,with two exit port T&C	出油片在右侧,两个出油口, T口和C口 Right outlet section,with two exit port T&C	U2	C口过桥, D口没有
	出油片在左侧,两个出油口, T口和D口 Left outlet section,with two exit port T&D	出油片在右侧,两个出油口, T口和D口 Right outlet section,with two exit port T&D	U23	D口过桥, C口堵塞

U1\*尾片内部结构(下图按三视图关系放置)  
尾片为U1\*形式时,过桥口内部堵头不装,此时T口、C口、D口相连通,可使用其中任一出口。

U1 outlet section material structure:  
The small port inside beyond port without plug, T port、C port and D port are connected,oil can flow out in anyone of them.

DCV35/60没有D口  
DCV35/60 no port D

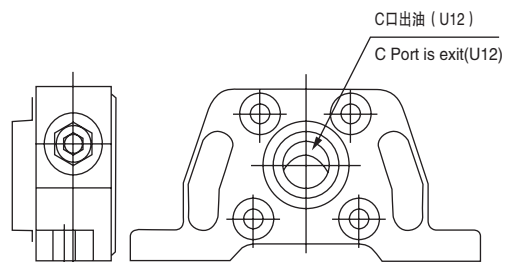
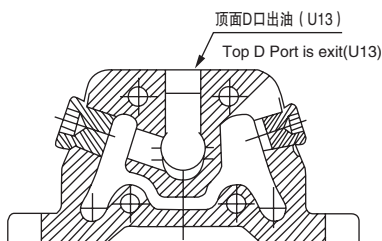

U2\*尾片内部结构(下图按三视图关系放置)  
尾片为U2\*形式时,过桥口内部装堵头,此时两个回油T口和C口 (D口)不通,此时T口回油用, C口或D口供另外油路使用。

U2outlet section material structure:  
The small port inside beyond port without plug,T port andC port (D port) are not connected,T port is used for oil return.C port(D port)is used for another oil-way.

DCV35/60没有D口  
DCV35/60 no port D

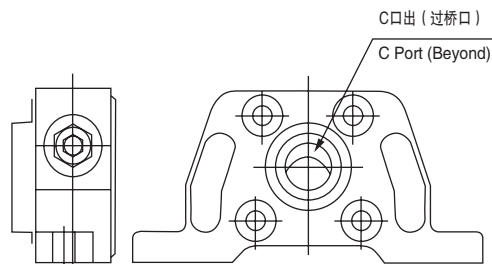
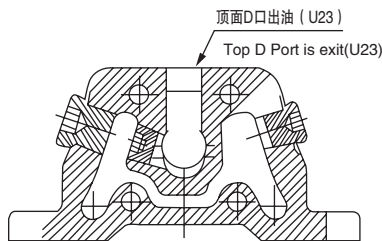

## DCV 分体式多路阀选型——出油口形式 THE CHOICES OF THE DCV SECTION VALVE——OUTLET SECTION

DCV*/*	E**	(*)	**	S**	C*	A*	Va*	Vb*	**	U**	**
--------	-----	-----	----	-----	----	----	-----	-----	----	-----	----

### DCV140/200 出油片 OUTLET SECTION

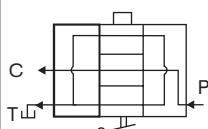
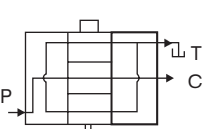
	出油片在左侧,T口(在尾片顶部)为出油口 Left outlet section,T is the exit port, on top of onset section		出油片在右侧,T口(在尾片顶部)为出油口 Right outlet section,T is the exit port, on top of onset section	U1	D口没有, C口堵塞
	出油片在左侧,C口(在尾片侧面)为出油口 Left outlet section,C is the exit port, and on side of outset section		出油片在右侧,C口(在尾片侧面)为出油口 Right outlet section,C is the exit port, and on side of outset section	U12	T口没有, D口堵塞
	出油片在左侧,两个出油口, T口和C口 Left outlet section,with two exit port T&C		出油片在右侧,两个出油口, T口和C口 Right outlet section,with two exit port T&C	U2	T、C口堵塞

U1\*尾片内部结构(下图按三视图关系放置)  
尾片为U1\*形式时,过桥口内部堵头不装,此时T口、C口、D口相连通,可使用其中任一出油口。

U1 outlet section material structure:  
The small port inside beyond port without plug,T port、C port and D port are connected,oil can flow out in anyone of them.

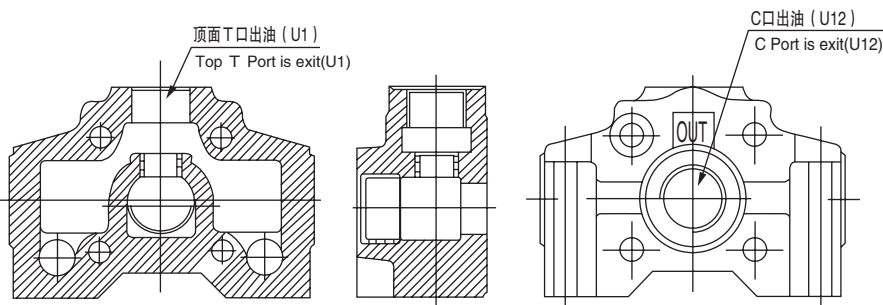

U2\*尾片内部结构(下图按三视图关系放置)  
尾片为U2\*形式时,过桥口内部装堵头,此时两个回油T口和C口(D口)不通,此时T口回油用,C口或D口供另外油路使用。

U2outlet section material structure:  
The small port inside beyond port without plug,T port and C port (D port) are not connected,T port is used for oil return.C port(D port)is used for another oil-way.

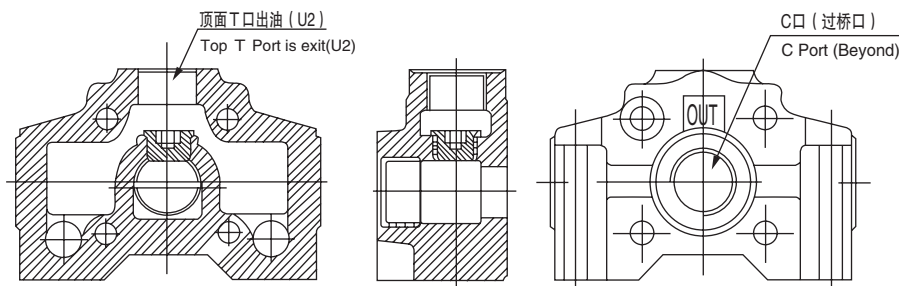

# DCV 分体式多路阀选型——出油口形式 THE CHOICES OF THE DCV SECTION VALVE——OUTLET SECTION

DCV*/*	E**	(*)	* *	S**	C*	A*	Va*	Vb*	* *	U**	* *
--------	-----	-----	-----	-----	----	----	-----	-----	-----	-----	-----

## DCV160/250 出油片 OUTLET SECTION

	出油片在左侧,T口(在尾片顶部)为出油口 Left outlet section,T is the exit port, on top of onset section	出油片在右侧,T口(在尾片顶部)为出油口 Right outlet section,T is the exit port, on top of onset section	U1	C口、D口堵塞 Y口没有
	出油片在左侧,C口(在尾片顶部)为出油口 Left outlet section,C is the exit port, on top of onset section	出油片在右侧,C口(在尾片顶部)为出油口 Right outlet section,C is the exit port, on top of onset section	U12	T口、D口堵塞 Y口没有
	出油片在左侧,D口(在尾片顶部)为出油口 Left outlet section,D is the exit port, on top of onset section	出油片在右侧,D口(在尾片顶部)为出油口 Right outlet section,D is the exit port, on top of onset section	U13	C口、T口堵塞 Y口没有
	出油片在左侧,Y口(在尾片顶部)为出油口 Left outlet section,Y is the exit port, on top of onset section	出油片在右侧,Y口(在尾片顶部)为出油口 Right outlet section,Y is the exit port, on top of onset section	U14	C口、D口堵塞 Y口没有
	出油片在左侧,两个出油口, C口和T口 Left outlet section,with two exit port C&T	出油片在右侧,两个出油口, C口和T口 Right outlet section,with two exit port C&T	U2	C口过桥 Y口、D口堵塞
	出油片在左侧,两个出油口, C口和Y口 Left outlet section,with two exit port C&Y	出油片在右侧,两个出油口, C口和Y口 Right outlet section,with two exit port C&Y	U22	C口过桥 D口、T口堵塞
	出油片在左侧,两个出油口, D口和T口 Left outlet section,with two exit port D&T	出油片在右侧,两个出油口, D口和T口 Right outlet section,with two exit port D&T	U23	D口过桥 C口、Y口堵塞
	出油片在左侧,两个出油口, D口和Y口 Left outlet section,with two exit port D&Y	出油片在右侧,两个出油口, D口和Y口 Right outlet section,with two exit port D&Y	U24	D口过桥 C口、T口堵塞

U1\*尾片内部结构(下图按三视图关系放置)  
尾片为U1\*形式时,过桥口内部堵头不装,  
此时T口、C口、D口、Y口相连通,  
可使用其中任一出口。

U1 outlet section material structure:  
The small port inside beyond port without plug,T port、C Port Dport and Yport are connected,oil can flow out in anyone of them.

U2\*尾片内部结构(下图按三视图关系放置)  
尾片为U2\*形式时,过桥口内部装堵头,  
此时回油T口(或Y口)和C口(或D口)不通,  
此时T口、Y口中任意一个口回油用,C口或D口中任一供另外油路使用。

U2 outlet section material structure:  
The small port inside beyond port without plug,T port (or Y port) and C port (D port) are not connected,T or Yport is used for oil return.C or D port(D port)is used for another oil-way.

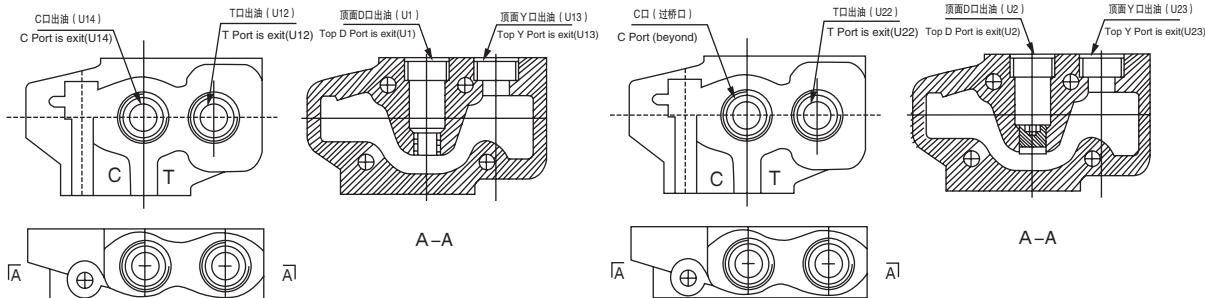

## DCV 分体式多路阀选型——油口尺寸 THE CHOICES OF THE DCV SECTION VALVE——SIZE OF THE PORTS

DCV*/*	E**	(*)	**	S**	C*	A*	Va*	Vb*	**	U**	**
产品型号 Code	DCV35										
标准油口尺寸 Standard ports Sizes	G3/8										
油口尺寸 Ports Sizes	G1/4	G3/8	M16x 1.5	NPT1/4	NPT3/8	1/2-20UNF	5/8-18UNF				
油口代号 Ports Codename	G04	G06	M16	N04	N06	N08	U10				
产品型号 Code	DCV60										
标准油口尺寸 Standard ports Sizes	G1/2										
油口尺寸 Ports Sizes	G3/8	G1/2	M20x 1.5	NPT3/8	NPT1/2	5/8-18UNF	3/4-18UNF				
油口代号 Ports Codename	G06	G08	M20	N06	N08	N10	U12				
产品型号 Code	DCV100										
标准油口尺寸 Standard ports Sizes	G3/4										
油口尺寸 Ports Sizes	G1/2	G3/4	M27x 2	NPT1/2	NPT3/4	3/4-16UNF	1-12UNF				
油口代号 Ports Codename	G08	G12	M27	N08	N12	N12	U16				
产品型号 Code	DCV140										
标准油口尺寸 Standard ports Sizes	G3/4										
油口尺寸 Ports Sizes	G3/4	G1	M33x 2	NPT3/4	NPT1	1-12UNF	11/8-12UNF				
油口代号 Ports Codename	G12	G16	M33	N12	N16	N16	U22				
产品型号 Code	DCV160首片			DCV160工作片				DCV160尾片			
标准油口尺寸 Standard ports Sizes	G1			G3/4				G1			
油口尺寸 Ports Sizes	G3/4	G1	M33x 2	NPT3/4	NPT1	1-12UNF	11/8-12UNF				
油口代号 Ports Codename	G12	G16	M33	N12	N16	N16	U22				
产品型号 Code	DCV200										
标准油口尺寸 Standard ports Sizes	G1										
油口尺寸 Ports Sizes	G3/4	G1	M33x 2	NPT3/4	NPT1	1-12UNF	11/8-12UNF				
油口代号 Ports Codename	G12	G16	M33	N12	N16	N16	U22				
产品型号 Code	DCV250										
标准油口尺寸 Standard ports Sizes	G1										
油口尺寸 Ports Sizes	G3/4	G1	M33x 2	NPT3/4	NPT1	1-12UNF	11/8-12UNF				
油口代号 Ports Codename	G12	G16	M33	N12	N16	N16	U22				

注：阴影部分为标准油口代码，其他为非标油口。

Notes: The shaded areas in the table is standard sizes, the others is nonstandard.

## DCV 分体式多路阀手柄尺寸 SIZE OF THE HANDLE IN THE DCV SECTION VALVE

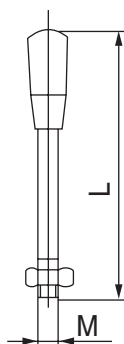

	M	L
DCV35	M8	170
DCV60	M10	210
DCV100	M10	210
DCV140	M10	210
DCV200	M12	260

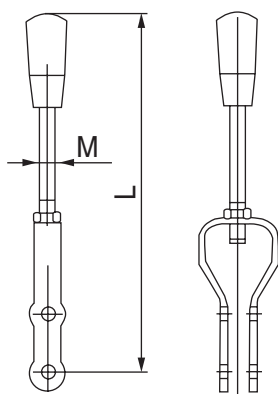

	M	L
DCV160	M10	222
DCV250	M12	230

材料说明:

- 1.手柄材料为尼龙;
- 2.手柄杆为45#钢, 表面防锈处理, 特殊的尺寸或形式可定制。

MATERIAL:

1. Handle:Nylon.
  2. Handle lever:Steel(45#) , it has been rreated against rust.
- We can produce exceptional size according to customers ' requirements.

# DCV 分体式多路阀 密封件 SEALS COMPONENT FOR DCV SECTION VALVE

## 维修密封件信息

### Information maintain seals

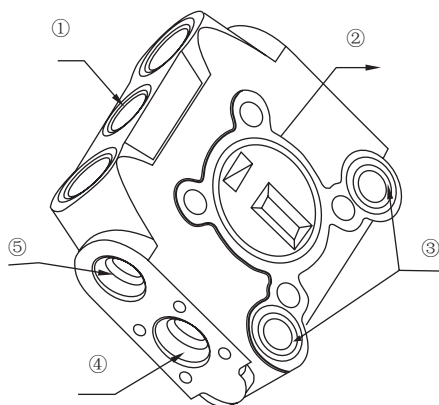

标\*处密封件:

Sign " \* " seals:

\*\*\*\* / \*\*\*\*

表示新结构密封件尺寸

Size of seals in new structure

表示旧结构密封件尺寸

Size of seals in old structure

型号 Type Of Valve	①		②		③
	O形圈或ED圈* O-Ring or Captive	密封挡圈 Back-Up Rings	O形圈或方形圈* O-Ring or Square-Ring		O形圈 O-Ring
DCV 35	9.19×2.62 (1pcs) / —	—	—/—		—
DCV 60	12.7×2.62 (1pcs) / —	13.08×2.18×1.35 (1pcs)	45.69×2.62 (1pcs) / 36.17×2.62		17.13×2.62 (2pcs)
DCV 100	19.3×2.2 (1pcs) / 19.6×24.3×1.5 (1pcs)	—	48.9×2.62 (1pcs) / 44.12×2.62		18.72×2.62 (2pcs)
DCV 140	19.3×2.2 (1pcs) / 19.6×24.3×1.5 (1pcs)	—	53.65×2.62 (1pcs) / —		21.89×2.62 (2pcs)
DCV 160	23.47×2.62 (1pcs) / —	—	33×2.62 (3pcs)	39.34×2.62 (1pcs) / —	—
DCV 200	23.47×2.62 (1pcs) / 23.9×29.2×1.5 (1pcs)	—	58.42×2.62 (1pcs) / 48.9×2.62		21.89×2.62 (2pcs)
DCV 250	23.47×2.62 (1pcs) / —	—	39.34×2.62 (3pcs)	45.69×2.62 (1pcs) / —	—
型号 Type Of Valve	④	⑤			
	O形圈 O-Ring	O形圈或ED圈* O-Ring or Captive	O形圈 O-Ring		密封挡圈 Back-Up Rings
DCV 35	11.7×2.62 (2pcs)	—/15.7×20.9×1.5 (2pcs)	11.8×1.8 (2pcs) 10.82×1.78 (2pcs)		—
DCV 60	17.13×2.62 (2pcs)	17.8×1.9 (2pcs) / 17.8×22.9×1.5 (2pcs)	14.8×1.9 (2pcs) 14×1.78 (2pcs)		14.4×1.3×1.24 (2pcs)
DCV 100	18.72×2.62 (2pcs)	19.8×1.9 (2pcs) / 19.6×24.3×1.5 (2pcs)	16×1.8 (2pcs) 13.95×2.62 (2pcs)		14.66×2.18×1.35 (2pcs)
DCV 140	18.72×2.62 (2pcs)	23.47×2.62 (2pcs) / 23.9×22.9×1.5 (2pcs)	16×1.8 (2pcs) 17.13×2.62 (2pcs)		17.6×2.18×1.35 (2pcs)
DCV 160	18.72×2.62 (2pcs)	23.47×2.62 (2pcs) / 23.9×22.9×1.5 (2pcs)	16×1.8 (2pcs) 17.13×2.62 (2pcs)		17.6×2.18×1.35 (2pcs)
DCV 200	21.89×2.62 (2pcs)	23.47×2.62 (2pcs) / 23.9×22.9×1.5 (2pcs)	19.8×1.9 (2pcs) 17.13×2.62 (2pcs)		17.6×2.18×1.35 (2pcs)
DCV 250	21.89×2.62 (2pcs)	23.47×2.62 (2pcs) / 23.9×22.9×1.5 (2pcs)	19.8×1.9 (2pcs) 17.13×2.62 (2pcs)		17.6×2.18×1.35 (2pcs)

# DCV60系列多路阀 SECTION VALVE DCV60

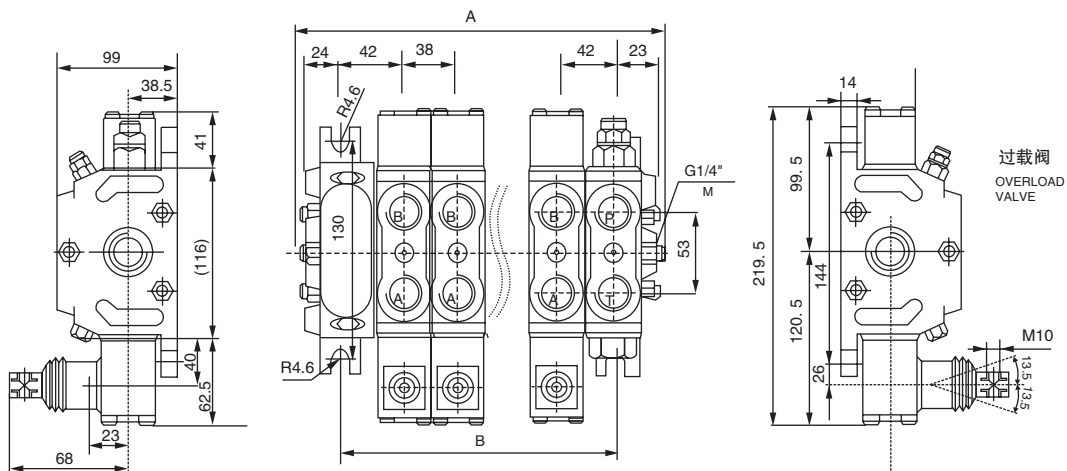

压力损失曲线  
Pressure Drop Flow Curves

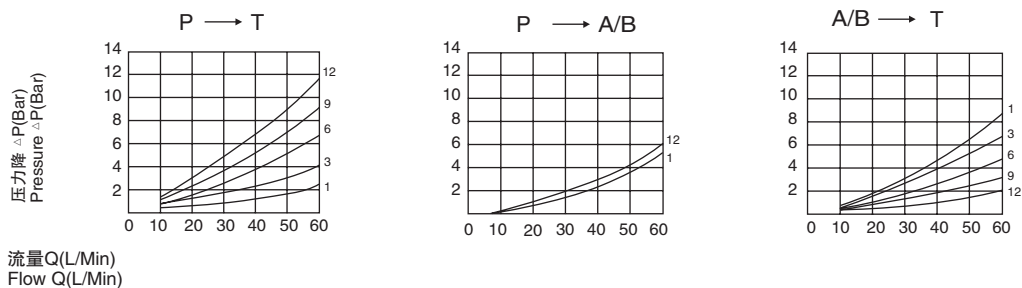

流量Q(L/Min)  
Flow Q(L/Min)

阀型号 TYPE OF VALVE	尺寸 DIMENSIONS			标准重量(公斤) WEIGHT(Kg)	
	A	B			
DCV 60/1	121	70		4.7	
DCV 60/2	153	102		6.4	
DCV 60/3	185	134		8.1	
DCV 60/4	217	166		9.8	
DCV 60/5	249	198		11.5	
DCV 60/6	281	230		13.2	
DCV 60/7	313	262		14.9	
DCV 60/8	345	294		16.6	
DCV 60/9	377	326		18.3	
DCV 60/10	409	358		20	
DCV 60/11	441	390		21.7	
DCV 60/12	473	422		23.4	
额定流量: 50升/分钟 Nominal Flow: 50L/Min	最大流量: 60升/分钟 Max. Flow: 60L/Min	最大压力: 315Bar Max. Working Pressure: 315Bar	标准螺纹: G1/2" Threads(standard):G1/2"	拉杆拧紧力矩: 55 ± 3N.m Tie-rod tightening torque: 55 ± 3N.m	阀芯行程: +5--5 Spool stroke: +5--5

# DCV60系列多路阀 SECTION VALVE DCV60

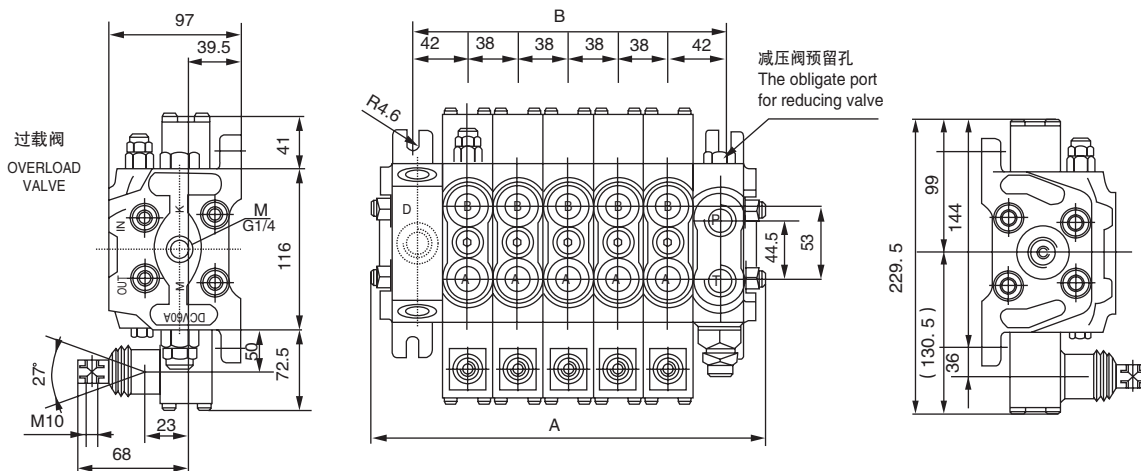

注：标准供货时D口没有  
Standard valves  
without D port



E2或E7  
带测压口G1/4 (标准结构)  
with testing port G1/4 (standard)



E24或E74  
带测面进口油口的首片  
with side P port



E25或E75  
用于带减压阀的首片结构中  
M测压口G1/4K供油口G1/4  
with reducing valve

压力损失曲线  
Pressure Drop Flow Curves

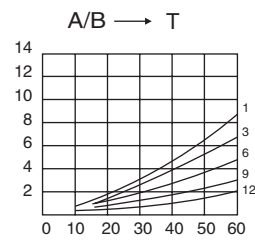
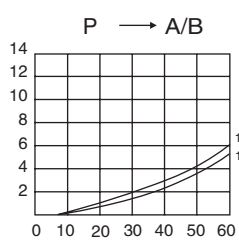
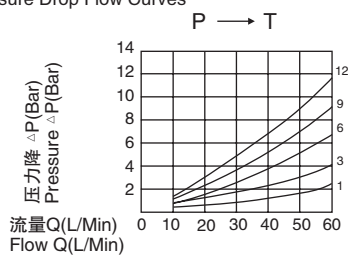

阀型号 TYPE OF VALVE	尺寸 DIMENSIONS		
	A	B	标准重量(公斤) WEIGHT(Kg)
DCV60/1	144	84	7.5
DCV60/2	182	122	10.1
DCV60/3	220	160	12.7
DCV60/4	258	198	15.3
DCV60/5	296	236	17.9
DCV60/6	334	274	20.5
DCV60/7	370	312	23.1
DCV60/8	410	350	25.7
DCV60/9	450	388	28.3
DCV60/10	486	426	30.9
DCV60/11	524	464	33.5
DCV60/12	562	502	36.1

额定流量: 50升/分钟 Nominal Flow: 50L/Min	最大流量: 60升/分钟 Max. Flow: 60L/Min	最大压力: 315Bar Max. Working Pressure: 315Bar	标准螺纹: G1/2" Threads(standard): G1/2"	拉杆拧紧力矩: 55 ± 3N.m Tie-rod tightening torque: 55 ± 3N.m	阀芯行程: +5~-5 Spool stroke: +5~-5
---------------------------------------	------------------------------------	--	---	--	------------------------------------

b30

DCV60系列多路阀

## DCV60系列多路阀 ( 定位控制 ) SECTION VALVE DCV60(DETENT)

定位结构分为带弹簧复位和不带弹簧复位两种。带弹簧复位结构分别有一个槽A定位、一槽B定位、二槽定位、三槽定位等多种，可以使阀体分别定在A位、B位、AB位、AOB位。不带弹簧复位结构仅提供AOB定位机能。可根据客户要求定制。机能控制代号见A71页。

The detent structures include two forms: spring centred spool & without spring centred spool. Spring centred spool have those several structures: detent in A, detent in B, detent in A and B, detent in A, B and O. Without spring centred spool only have one structure: detent in A, B and O. We can made the products in accordance with particular instructions or requirements of the customers. The code of detent see page A71.

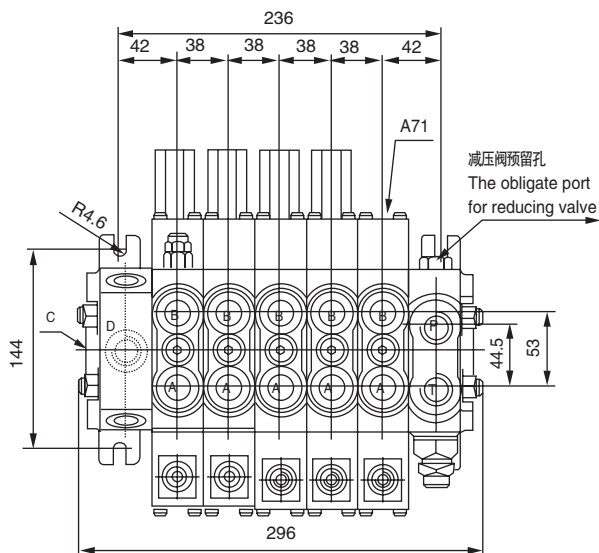
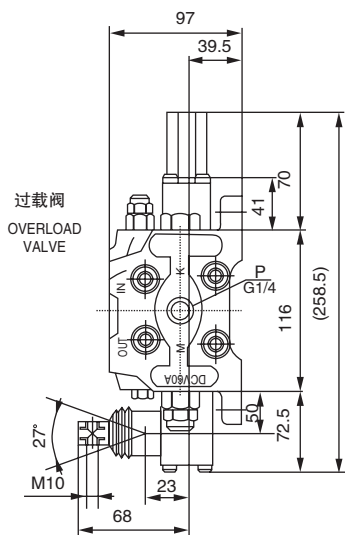
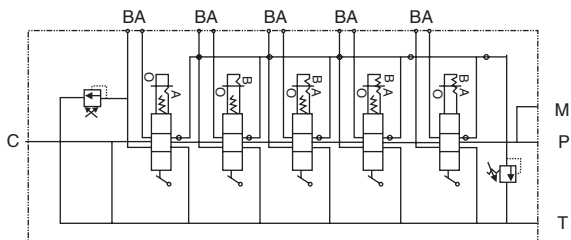

注: 标准供货时D口没有  
Standard valves  
without D port

额定流量: 50升/分钟 Nominal Flow: 50L/Min	最大流量: 60升/分钟 Max. Flow: 60L/Min	最大压力: 315Bar Max. Working Pressure: 315Bar	标准螺纹: G1/2" Threads (standard): G1/2"	拉杆拧紧力矩: 55 ± 3N.m Tie-rod tightening torque: 55 ± 3N.m	阀芯行程: +5~-5 Spool stroke: +5~-5
---------------------------------------	------------------------------------	--	--	--	------------------------------------

# DCV60系列多路阀 SECTION VALVE DCV60

气缸控制多路换向阀，控制压力5~10bar,油缸控制  
多路换向阀，控制压力10~13bar

ON-OFF pneumatic control, Pilot pressure 5 ~10bar

ON-OFF hydraulic control, Pilot pressure 10 ~13bar

控制方式 Control Mode	控制口尺寸 Control port Size	控制机能代号 Order Code
气缸控制 Pneumatic control	G1/8	A14
油缸控制 Hydraulic control	G1/4	A24

气缸控制  
Pneumatic control

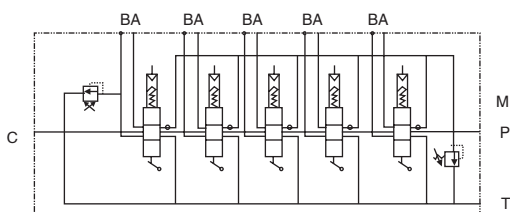

油缸控制  
Hydraulic control

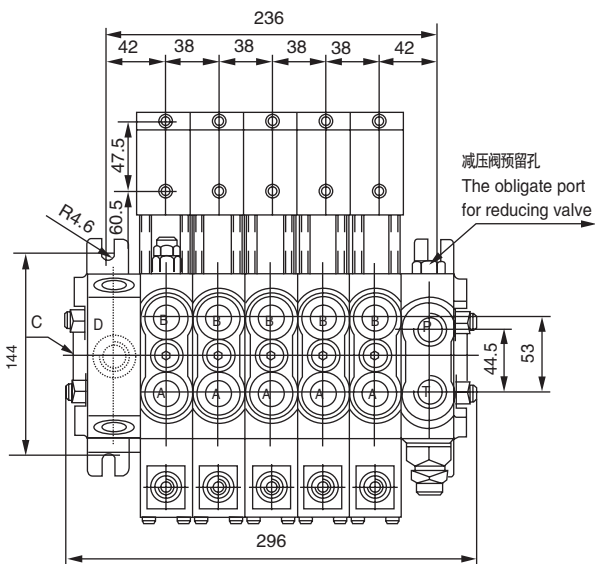
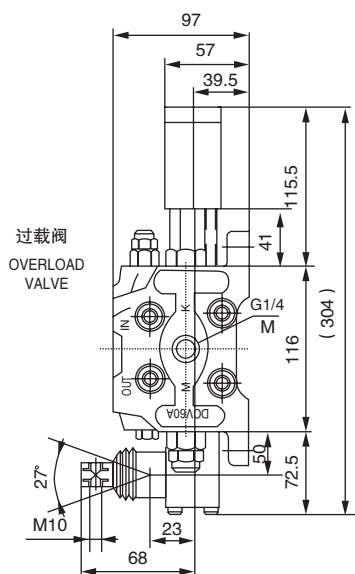
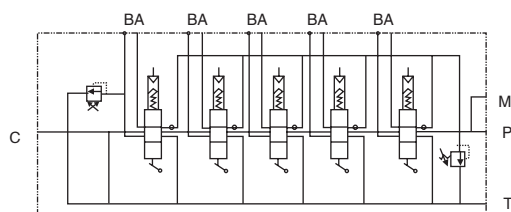

注：标准供货时D口没有  
Standard valves  
without D port

额定流量：50升/分钟 Nominal Flow: 50L/Min	最大流量：60升/分钟 Max. Flow: 60L/Min	最大压力：315Bar Max. Working Pressure: 315Bar	标准螺纹：G1/2" Threads (standard): G1/2"	拉杆拧紧力矩：55 ± 3N.m Tie-rod tightening torque: 55 ± 3N.m	阀芯行程：+5~-5 Spool stroke: +5~-5
--------------------------------------	-----------------------------------	---	---	---	-----------------------------------

b32

DCV60系列多路阀

## DCV60系列多路阀 ( 电液控换向阀 ) SECTION VALVE DCV60(ELECTROHYDRAULIC CONTROL)

此电液/手动控制应用有许多变化组合,本样本仅举一例,更多具体应用要求,我们可根据客户要求定制,例如右侧进油,12V或24V等要求。

使用电液控制需提供实际使用工况,使用压力、使用流量等参数。产品出厂前根据用户工况调试好。建议选用产品前咨询我们销售或技术部门。机能控制代号: A15、A16。

The application of electrohydraulic control and handle control have a lot of combination. In the catalogue, we give you only one example of them. We can made the products in accordance with particular instructions or requirements of the customers. For example: right inlet section. 12V or 24V. etc.

You should present the status pressure and flow before the order. For us to debug the valves before the consignment. We suggest that when you choose the valve please refer to our seller or technical adviser. The code is A15 or A16.

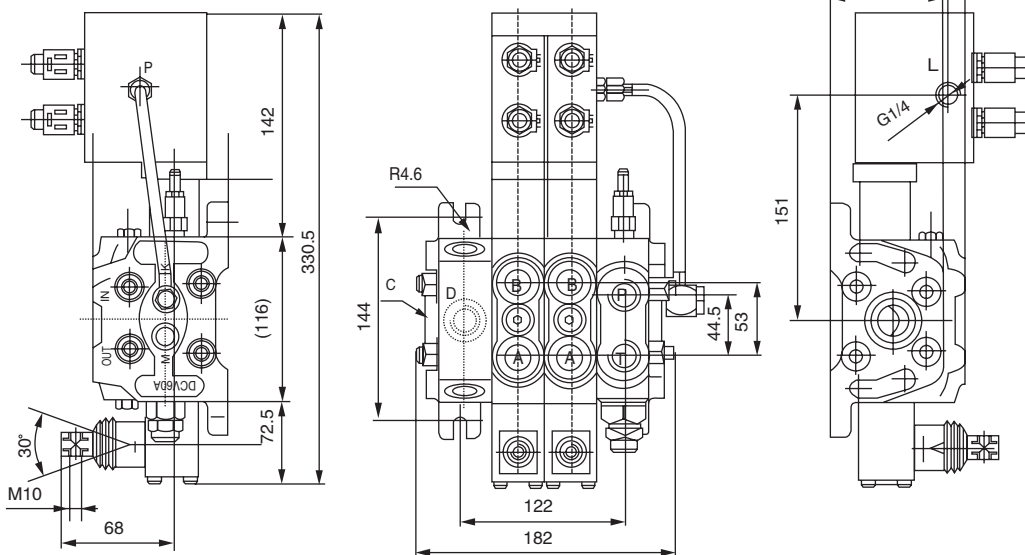
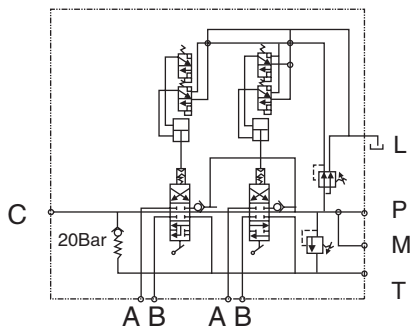

注:1.此型号电液控产品首片形式为E25或E75  
2.标准供货时D口没有。  
1. The form of inlet section is E25 or E75  
2. Standard valves without D port.

额定流量: 50升/分钟 Nominal Flow: 50L/Min	最大流量: 60升/分钟 Max. Flow: 60L/Min	最大压力: 315Bar Max. Working Pressure: 315Bar	标准螺纹: G1/2" Threads (standard): G1/2"	拉杆拧紧力矩: 55 ± 3N.m Tie-rod tightening torque: 55 ± 3N.m	阀芯行程: +5--5 Spool stroke: +5--5
---------------------------------------	------------------------------------	---	--	---	------------------------------------

## DCV60系列多路阀 (液控) SECTION VALVE DCV60(HYDRAULIC CONTROL)

订货时请告知配套先导阀参数。标准产品设计满足5~30bar的先导控制压力范围。特殊要求请咨询我们技术部门。机能操纵代号:C4

Please tell us the data of the hydraulic remote control when you order it. The normal pilot pressure is 5~30 bar. When you have special requirement please tell our technical adviser. The code is C4.

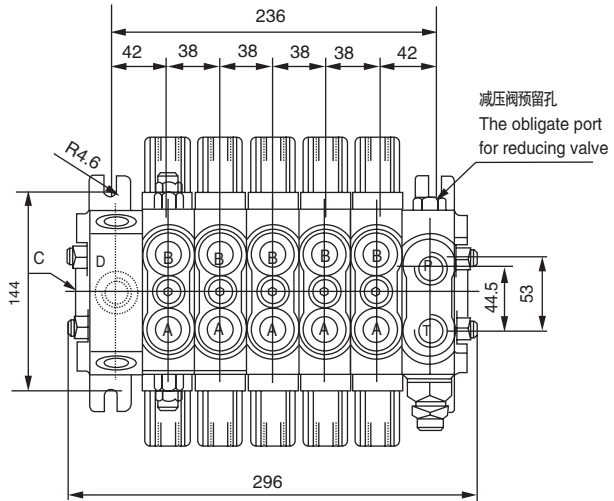
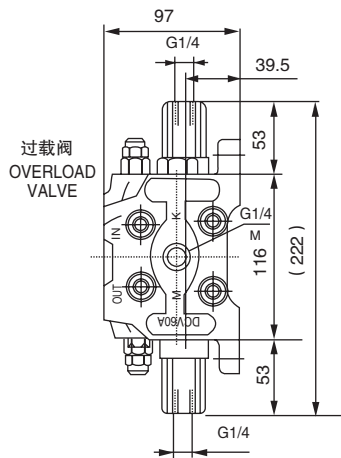
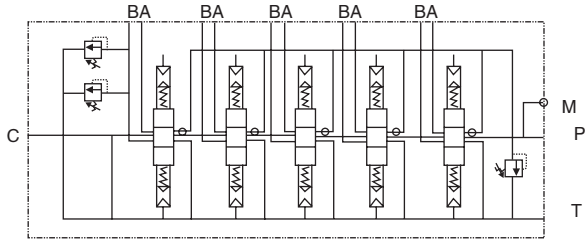

注: 标准供货时D口没有  
Standard valves  
without D port

额定流量: 50升/分钟 Nominal Flow: 50L/Min	最大流量: 60升/分钟 Max. Flow: 60L/Min	最大压力: 315Bar Max. Working Pressure: 315Bar	标准螺纹: G1/2" Threads (standard): G1/2"	拉杆拧紧力矩: 55 ± 3N.m Tie-rod tightening torque: 55 ± 3N.m	阀芯行程: +5~-5 Spool stroke: +5~-5
---------------------------------------	------------------------------------	---	--	---	------------------------------------

b34

DCV60系列多路阀

## DCV60系列多路阀 ( 双控操纵 ) SECTION VALVE DCV60( DOUBLE CONTROL)

预留的,双控操纵(N表示内螺纹连接),机能控制代号A13、A13N。

Prearranged for double control(N means the screw thread is inside).The code is A13 or A13N.

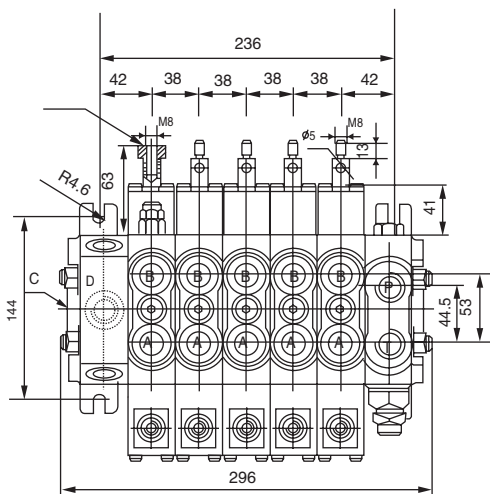
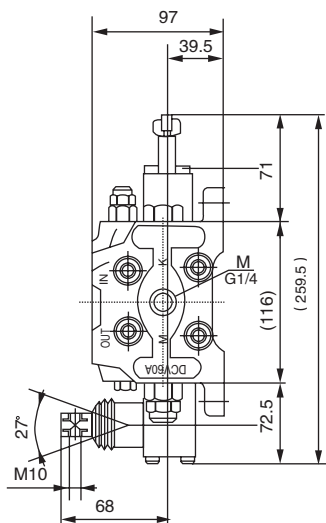
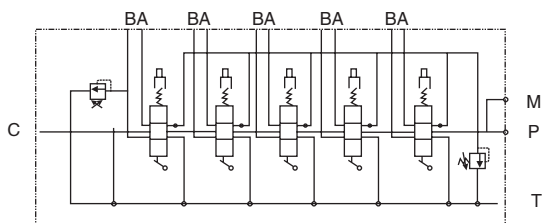

注: 标准供货时D口没有  
Standard valves  
without D port

额定流量: 50升/分钟 Nominal Flow: 50L/Min	最大流量: 60升/分钟 Max. Flow: 60L/Min	最大压力: 315Bar Max. Working Pressure: 315Bar	标准螺纹: G1/2" Threads(standard): G1/2"	拉杆拧紧力矩: 55 ± 3N.m Tie-rod tightening torque: 55 ± 3N.m	阀芯行程: +5--5 Spool stroke: +5--5
---------------------------------------	------------------------------------	--	---	--	------------------------------------

b35

DCV60系列多路阀

# DCV100系列多路阀 SECTION VALVE DCV100

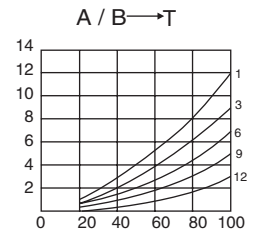
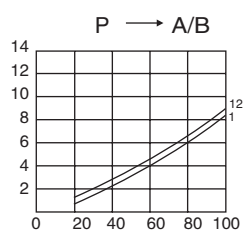
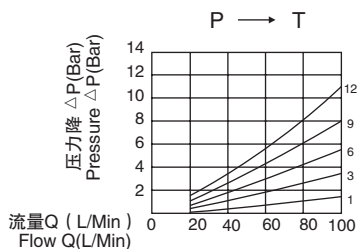
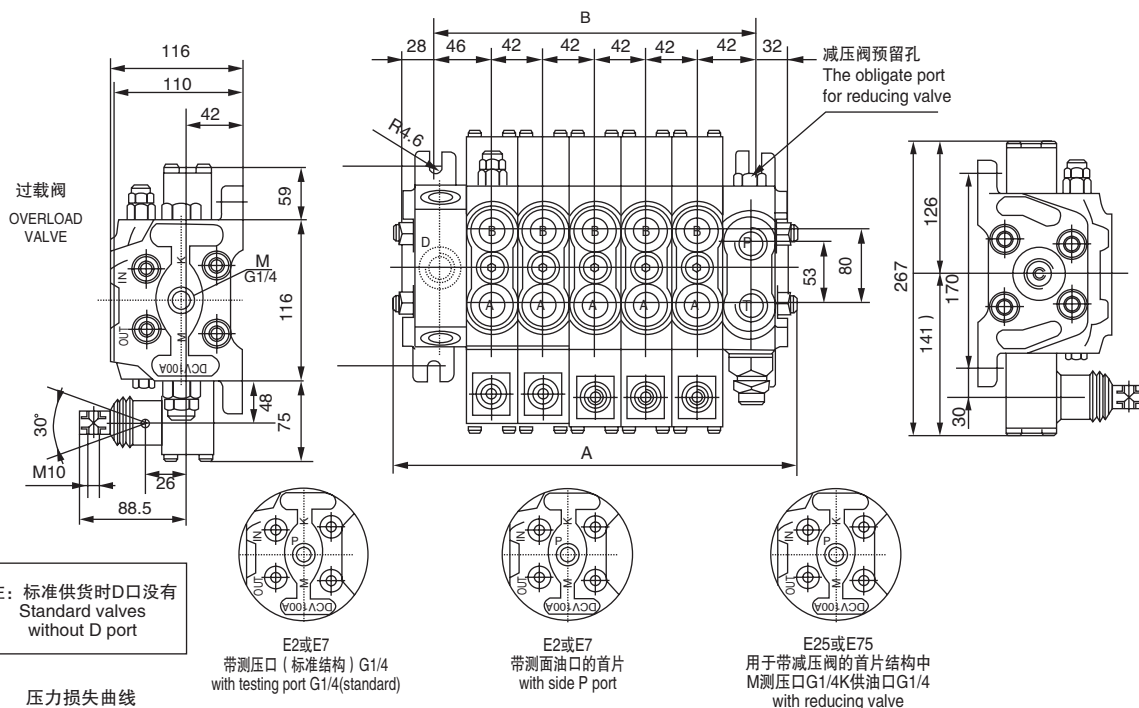

阀型号 TYPE OF VALVE	尺寸 DIMENSIONS		
	A	B	标准重量(公斤) WEIGHT(Kg)
DCV 100/1	158	88	9.8
DCV 100/2	200	130	13.7
DCV 100/3	242	172	17.6
DCV 100/4	284	214	21.5
DCV 100/5	326	256	25.4
DCV 100/6	370	298	29.3
DCV 100/7	410	340	32.2
DCV 100/8	450	382	37.1
DCV 100/9	497	424	41
DCV 100/10	536	466	44.9
DCV 100/11	578	508	48.8
DCV 100/12	620	550	52.7

额定流量: 80升/分钟 Nominal Flow: 80L/Min	最大流量: 100升/分钟 Max. Flow: 100L/Min	最大压力: 315Bar Max. Working Pressure: 315Bar	标准螺纹: G3/4" Threads (standard): G3/4"	拉杆拧紧力矩: 55 ± 3N.m Tie-rod tightening torque: 55 ± 3N.m	阀芯行程: +7--7 Spool stroke: +7--7
---------------------------------------	--------------------------------------	--	--	--	------------------------------------

b36  
DCV100系列多路阀

## DCV100系列多路阀 ( 定位控制 ) SECTION VALVE DCV100(DETENT)

定位结构分为带弹簧复位和不带弹簧复位两种。带弹簧复位结构分别有一槽A定位、一槽B定位、二槽定位、三槽定位等多种，可以使阀体分别定在A位、B位、AB位、AOB位。不带弹簧复位结构仅提供AOB定位功能。可根据客户要求定制。机能控制代号见A71页。

The detent structures include two forms: spring centred spool & without spring centred spool. Spring centred spool have those several structures: detent in A、detent in B、detent in A and B、detent in A、B and O. Without spring centred spool only have one structure: detent in A、B and O. We can made the products in accordance with particular instructions or requirements of the customers. The code of detent see page A71.

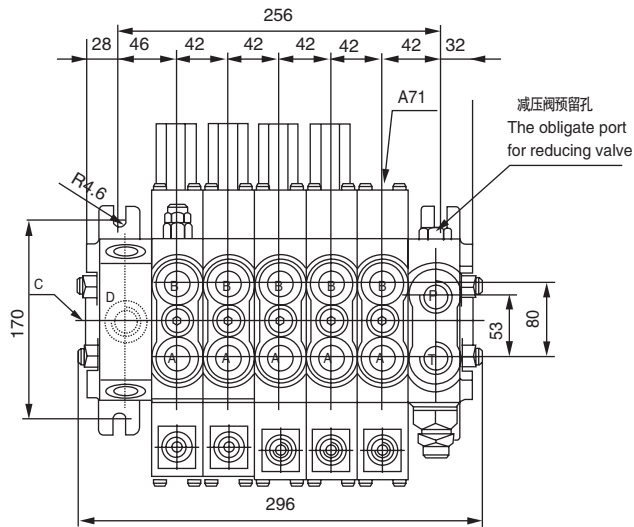
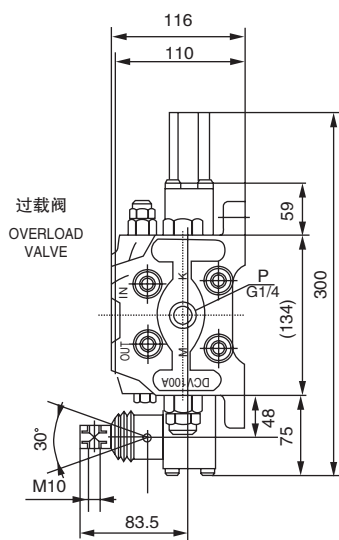
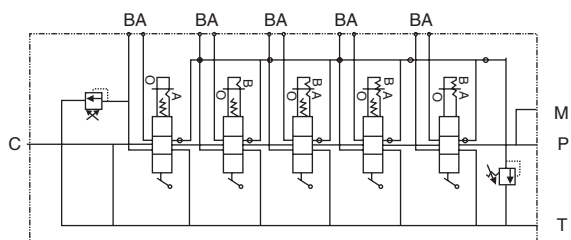

注：标准供货时D口没有  
Standard valves  
without D port

额定流量：80升/分钟 Nominal Flow: 80L/Min	最大流量：100升/分钟 Max. Flow: 100L/Min	最大压力：315Bar Max. Working Pressure: 315Bar	标准螺纹：G3/4" Threads (standard): G3/4"	拉杆拧紧力矩：55 ± 3N.m Tie-rod tightening torque: 55 ± 3N.m	阀芯行程：+7--7 Spool stroke: +7--7
--------------------------------------	-------------------------------------	---	---	---	-----------------------------------

# DCV100系列多路阀 ( 气缸控制/油缸控制 ) SECTION VALVE DCV100(PNEUMATIC/HYDRAULIC CONTROL)

气缸控制多路换向阀, 控制压力5 ~10bar,油缸控制  
多路换向阀, 控制压力10 ~13bar  
ON-OFF pneumatic control, Pilot pressure 5 ~10bar  
ON-OFF hydraulic control, Pilot pressure 10 ~13bar

控制方式 Control Mode	控制口尺寸 Control port Size	控制机能代号 Order Code
气缸控制 Pneumatic control	G1/8	A14
油缸控制 Hydraulic control	G1/4	A24

气缸控制  
Pneumatic Control

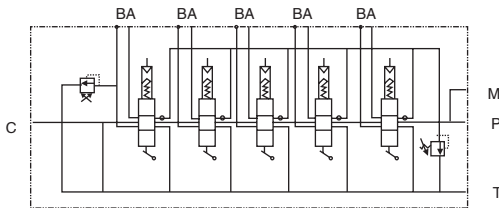

油缸控制  
Hydraulic control

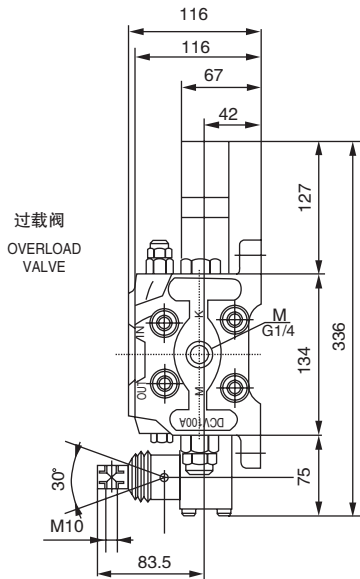
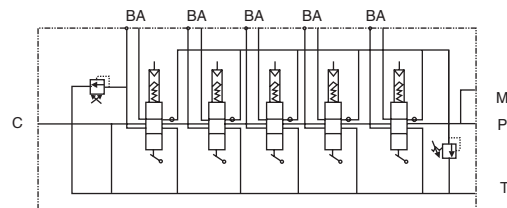

注: 标准供货时D口没有  
Standard valves  
without D port

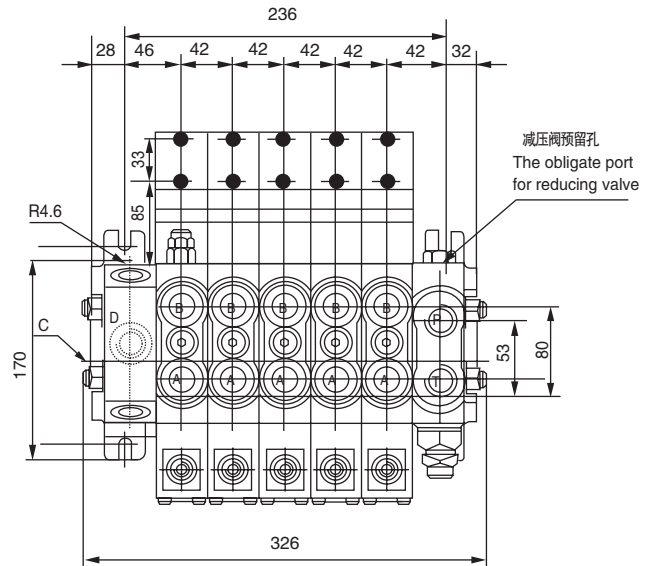

额定流量: 80升/分钟 Nominal Flow: 80L/Min	最大流量: 100升/分钟 Max. Flow: 100L/Min	最大压力: 315Bar Max. Working Pressure: 315Bar	标准螺纹: G3/4" Threads(standard): G3/4"	拉杆拧紧力矩: 55 ± 3N.m Tie-rod tightening torque: 55 ± 3N.m	阀芯行程: +7~-7 Spool stroke: +7~-7
---------------------------------------	--------------------------------------	--	---	--	------------------------------------

## DCV100系列多路阀 ( 电液控换向阀 ) SECTION VALVE DCV100(ELECTROHYDRAULIC CONTROL)

此电液/手动控制应用有许多变化组合,本样本仅举一例,更多具体应用要求,我们可根据客户要求定制,例如右侧进油,12V或24V等要求。

使用电液控制时需提供实际使用工况,使用压力、使用流量等参数。产品出厂前根据用户工况调试好。建议选用产品前咨询我们销售或技术部门。机能控制代号: A15、A16。

The application of electrohydraulic control and handle control have a lot of combination. In the catalogue, we give you only one example of them. We can made the products in accordance with particular instructions or requirements of the customers. For example: right inlet section. 12V or 24V. etc.

You should present the status pressure and flow before the order. For us to debug the valves before the consignment. We suggest that when you choose the valve please refer to our seller or technical adviser. The code is A15 or A16.

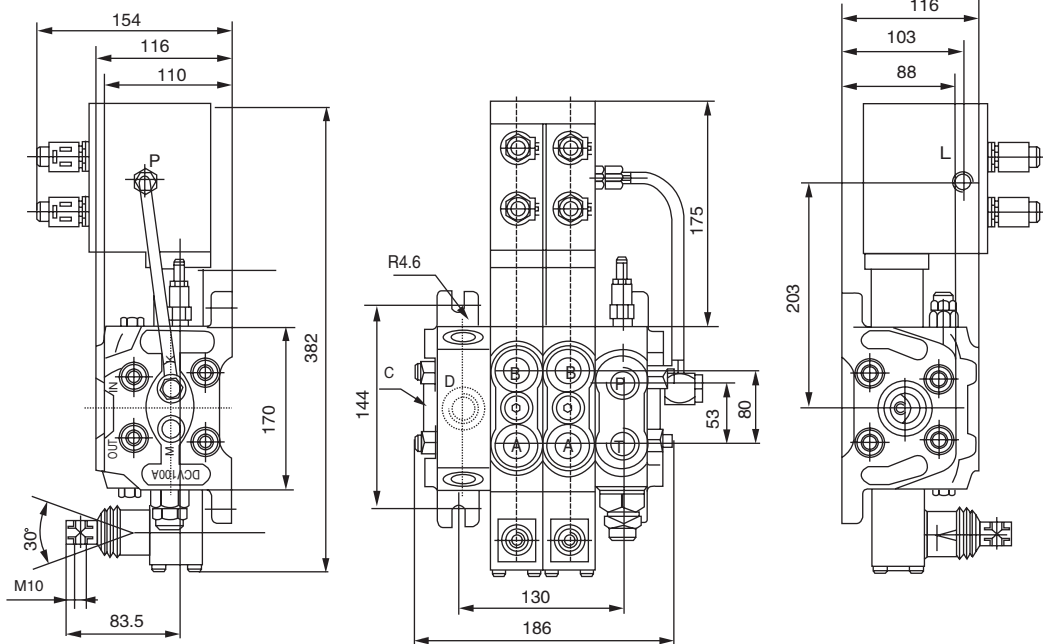
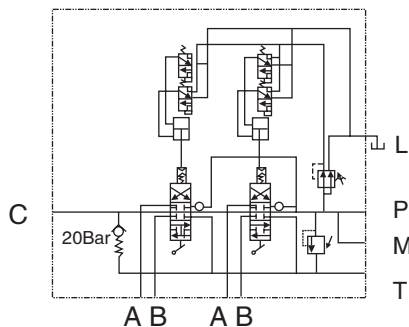

- 注:1.此型号电液控产品首片形式为E25或E75  
2.标准供货时D口没有。  
1.The form of inlet section is E25 or E75  
2.Standard valves without D port.

额定流量: 80升/分钟 Nominal Flow: 80L/Min	最大流量: 100升/分钟 Max. Flow: 100L/Min	最大压力: 315Bar Max. Working Pressure: 315Bar	标准螺纹: G3/4" Threads (standard): G3/4"	拉杆拧紧力矩: 55 ± 3N.m Tie-rod tightening torque: 55 ± 3N.m	阀芯行程: +7~-7 Spool stroke: +7~-7
---------------------------------------	--------------------------------------	--	--	--	------------------------------------

# DCV100系列多路阀 (液控) SECTION VALVE DCV100 (HYDRAULIC CONTROL)

订货时请告知配套先导阀参数。标准产品设计满足5~30bar的先导控制压力范围。特殊要求请咨询我们技术部门。机能操纵代号:C4

Please tell us the data of the hydraulic remote control when you order it. The normal pilot pressure is 5~30 bar. When you have special requirement please tell our technical adviser. The code is C4.

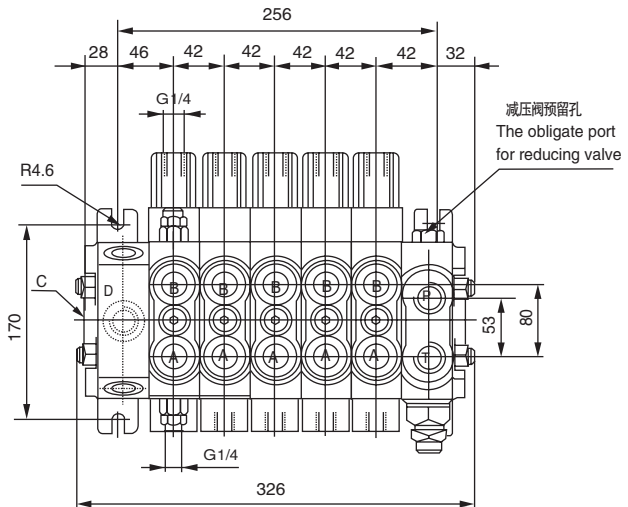
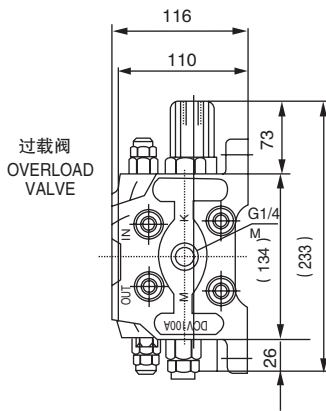
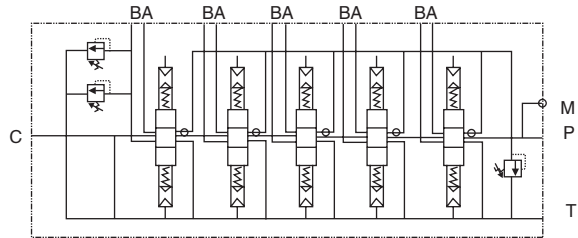

注: 标准供货时D口没有  
Standard valves  
without D port

额定流量: 80升/分钟 Nominal Flow: 80L/Min	最大流量: 100升/分钟 Max. Flow: 100L/Min	最大压力: 315Bar Max. Working Pressure: 315Bar	标准螺纹: G3/4" Threads (standard): G3/4"	拉杆拧紧力矩: 55 ± 3N.m Tie-rod tightening torque: 55 ± 3N.m	阀芯行程: +7--7 Spool stroke: +7--7
---------------------------------------	--------------------------------------	--	--	--	------------------------------------

# DCV100系列多路阀 (双控操纵) SECTION VALVE DCV100 (DOUBLE CONTROL)

预留的,双控操纵(N表示内螺纹连接),机能控制  
代号A13、A13N。  
Prearranged for double control(N means the screw  
thread is inside). The code is A13 or A13N.

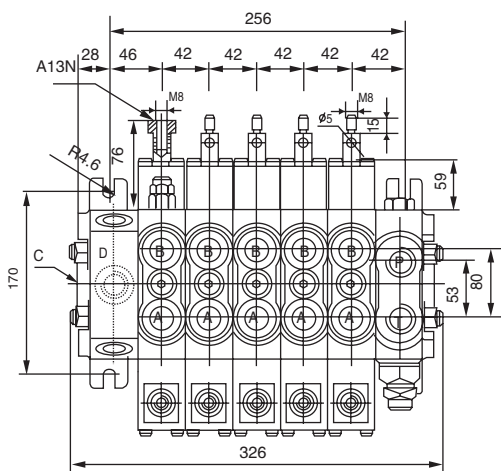
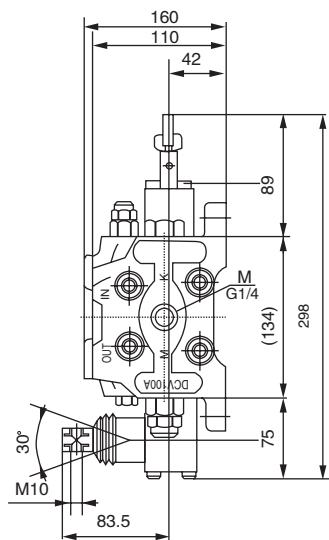
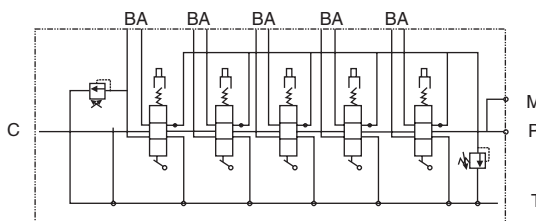

注: 标准供货时D口没有  
Standard valves  
without D port

额定流量: 80升/分钟 Nominal Flow: 80L/Min	最大流量: 100升/分钟 Max. Flow: 100L/Min	最大压力: 315Bar Max. Working Pressure: 315Bar	标准螺纹: G3/4" Threads(standard):G3/4"	拉杆拧紧力矩: 55 ± 3N.m Tie-rod tightening torque: 55 ± 3N.m	阀芯行程: +7--7 Spool stroke: +7--7
---------------------------------------	--------------------------------------	--	--	--	------------------------------------

# DCV140系列多路阀 SECTION VALVE DCV140

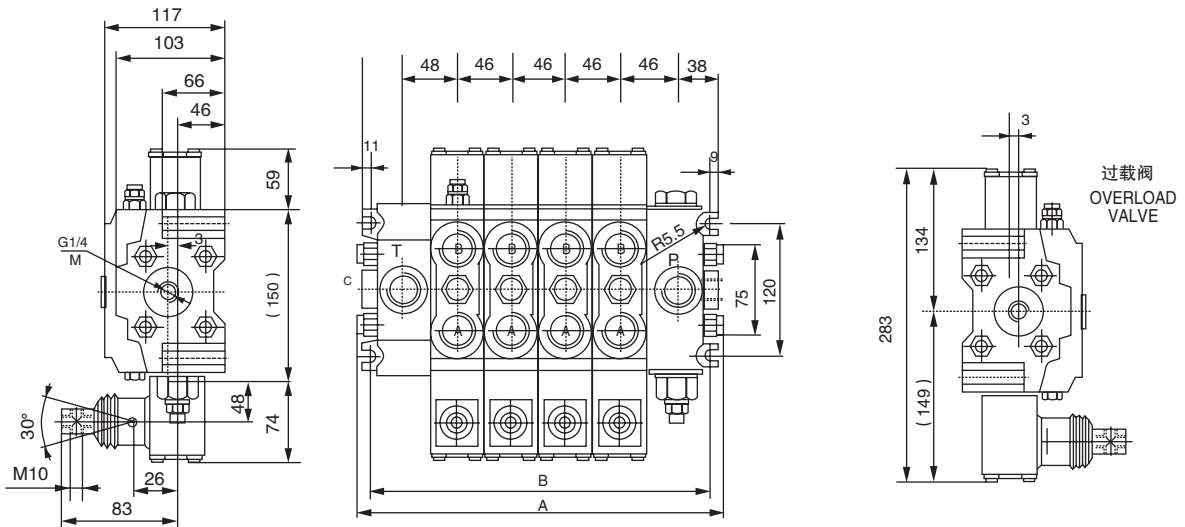

压力损失曲线  
Pressure Drop Flow Curves

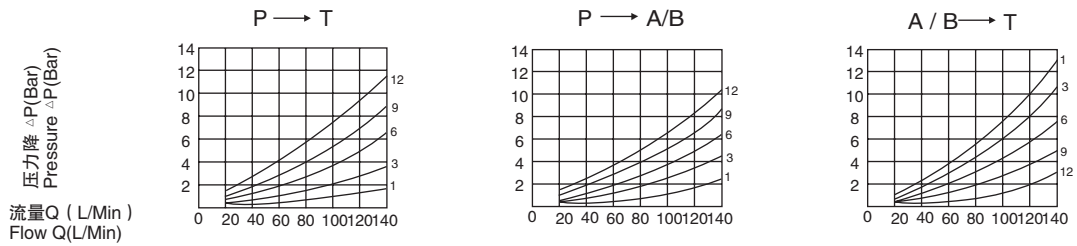

阀型号 TYPE OF VALVE	尺寸 DIMENSIONS				
	A	B	标准重量(公斤) WEIGHT(Kg)		
DCV 140/1	175	150	12.8		
DCV 140/2	221	196	18.1		
DCV 140/3	267	242	23.4		
DCV 140/4	313	288	28.6		
DCV 140/5	359	334	33.9		
DCV 140/6	405	380	39.2		
DCV 140/7	451	426	44.5		
DCV 140/8	497	472	49.8		
DCV 140/9	543	518	55		
DCV 140/10	589	564	60		
DCV 140/11	635	610	65.6		
DCV 140/12	681	656	70.9		
额定流量: 100升/分钟 Nominal Flow: 100L/Min	最大流量: 140升/分钟 Max. Flow: 140L/Min	最大压力: 315Bar Max. Working Pressure: 315Bar	标准螺纹: G3/4" Threads(standard): G3/4"	拉杆拧紧力矩: 55 ± 3N.m Tie-rod tightening torque: 55 ± 3N.m	阀芯行程: +7~-7 Spool stroke: + 7~-7

b42

DCV140系列多路阀

## DCV140系列多路阀 ( 定位控制 ) SECTION VALVE DCV140(DETENT)

定位结构分为带弹簧复位和不带弹簧复位两种。带弹簧复位结构分别有一个槽A定位、一槽B定位、二槽定位、三槽定位等多种，可以使阀体分别定在A位、B位、AB位、AOB位。不带弹簧复位结构仅提供AOB定位机能。可根据客户要求定制。机能控制代号见A71页。

The detent structures include two forms: spring centred spool & without spring centred spool. Spring centred spool have those several structures: detent in A, detent in B, detent in A and B, detent in A, B and O. Without spring centred spool only have one structure: detent in A, B and O. We can made the products in accordance with particular instructions or requirements of the customers. The code of detent see page A71.

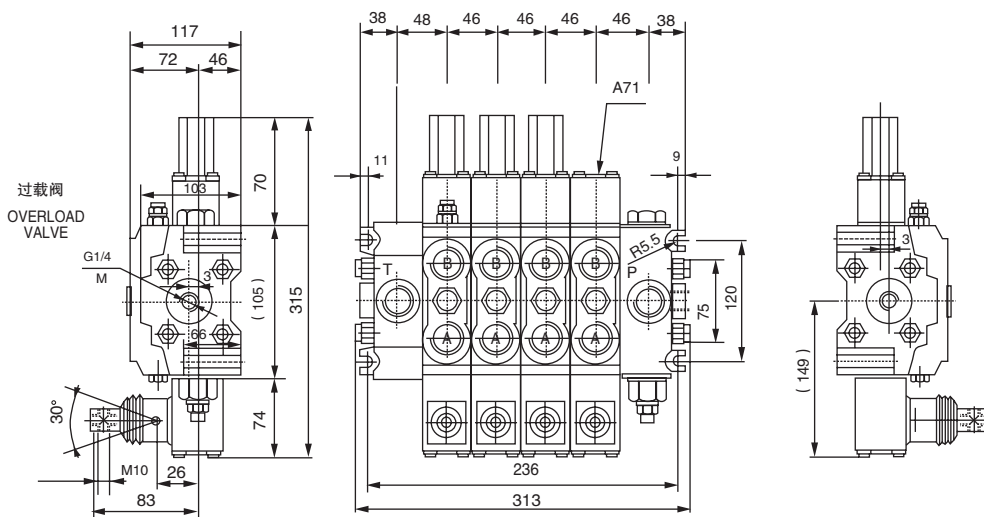
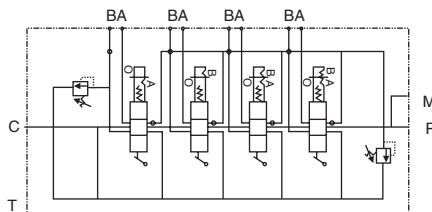

额定流量: 100升/分钟  
Nominal Flow: 100L/Min

最大流量: 140升/分钟  
Max. Flow: 140L/Min

最大压力: 315Bar  
Max. Working Pressure:  
315Bar

标准螺纹: G3/4"  
Threads (standard): G3/4"

拉杆拧紧力矩: 55 ± 3N.m  
Tie-rod tightening  
torque: 55 ± 3N.m

阀芯行程: +7--7  
Spool stroke: +7--7

# DCV140系列多路阀 ( 气缸控制/油缸控制 ) SECTION VALVE DCV140(PNEUMATIC/HYDRAULIC CONTROL)

气缸控制多路换向阀, 控制压力5~10bar,油缸控制多路换向阀, 控制压力10~13bar

ON-OFF pneumatic control, Pilot pressure 5~10bar

ON-OFF hydraulic control, Pilot pressure 10~13bar

控制方式 Control Mode	控制口尺寸 Control port Size	控制机能代号 Order Code
气缸控制 Pneumatic control	G1/8	A14
油缸控制 Hydraulic control	G1/4	A24

气缸控制  
Pneumatic control

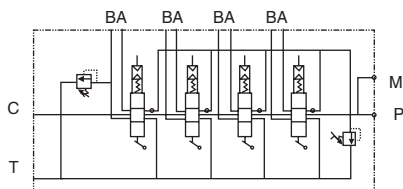

油缸控制  
Hydraulic control

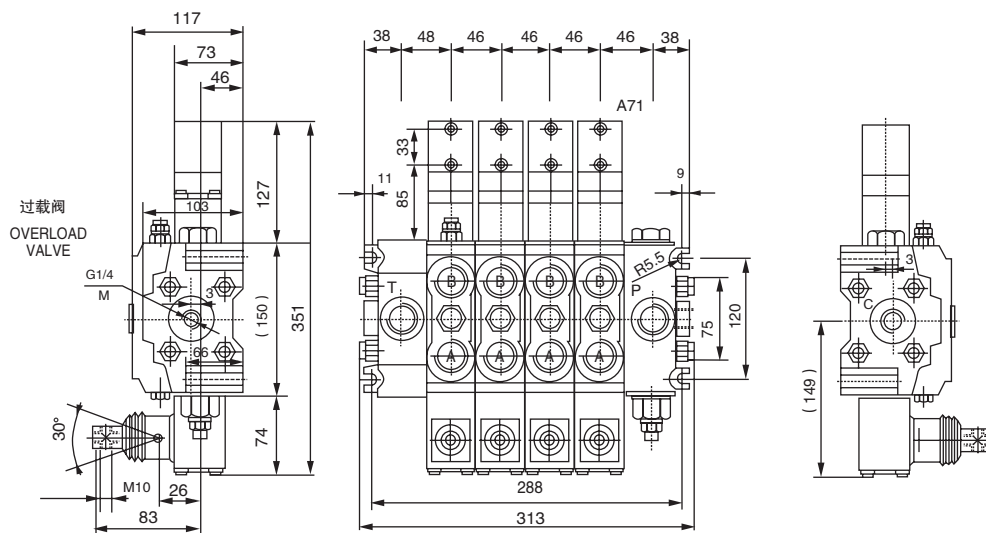
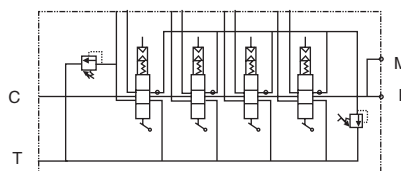

额定流量: 100升/分钟 Nominal Flow: 100L/Min	最大流量: 140升/分钟 Max. Flow: 140L/Min	最大压力: 315Bar Max. Working Pressure: 315Bar	标准螺纹: G3/4" Threads (standard): G3/4"	拉杆拧紧力矩: 55 ± 3N.m Tie-rod tightening torque: 55 ± 3N.m	阀芯行程: +7--7 Spool stroke: +7--7
---	--------------------------------------	---	--	---	------------------------------------

b44

DCV140系列多路阀

## DCV140系列多路阀 (液控) SECTION VALVE DCV140 (HYDRAULIC CONTROL)

订货时请告知配套先导阀参数。标准产品设计满足5~30bar的先导控制压力范围。特殊要求请咨询我们技术部门。机能操纵代号:C4

Please tell us the data of the hydraulic remote control when you order it. The normal pilot pressure is 5~30 bar. When you have special requirement please tell our technical adviser. The code is C4.

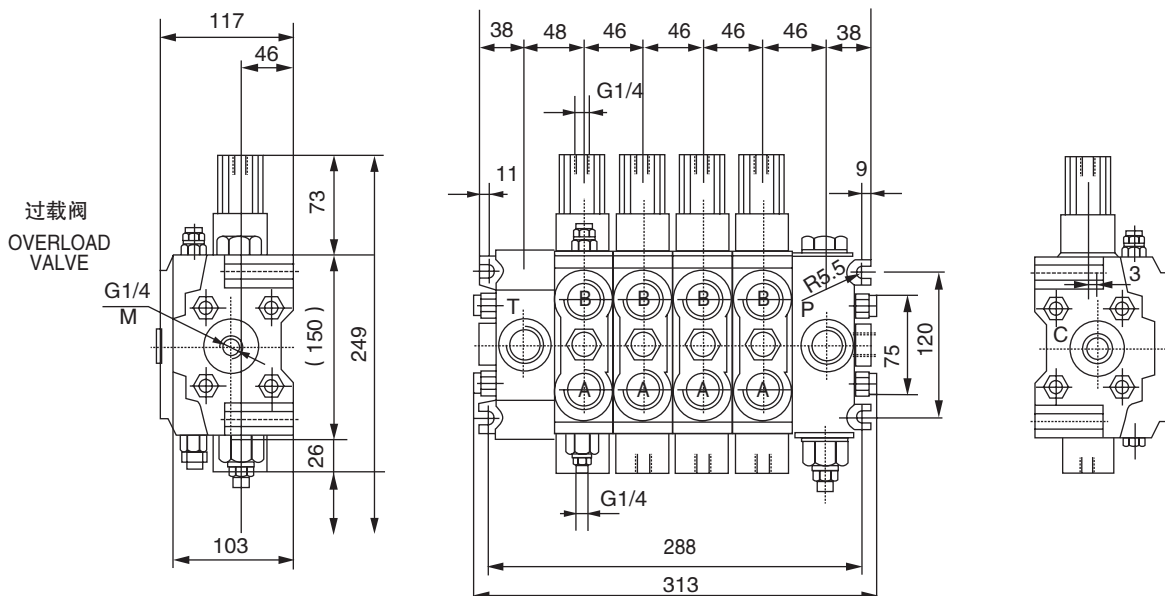
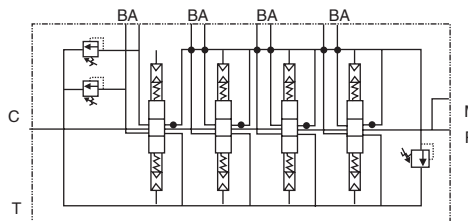

额定流量: 100升/分钟 Nominal Flow: 100L/Min	最大流量: 140升/分钟 Max. Flow: 140L/Min	最大压力: 315Bar Max. Working Pressure: 315Bar	标准螺纹: G3/4" Threads (standard): G3/4"	拉杆拧紧力矩: 55 ± 3N.m Tie-rod tightening torque: 55 ± 3N.m	阀芯行程: +7--7 Spool stroke: +7--7
---	--------------------------------------	--	--	--	------------------------------------

# ZS系列参数

## ZS Series Sectional Directional Control Valves

### 用途与特征/APPLICATIONS&FEATURES

ZS系列多路换向阀是一种以手动换向为主体的组合阀。它主要用于工程机械、矿山机械、起重运输机械和其他机械液压系统，用于改变液流方向，实行多个执行机构的集中控制。

ZS series multiple directional control valve is a kind of combination valve based on manual control. It's mainly used in mechanical hydraulic systems such as engineering machinery, mining machinery, Crane and Carriage Machinery, etc. to change flow direction and to execute integrated control over several executive mechanism.

### 性能参数/SPECIFICATIONS

型 号 Model	公称通径/Nom. dim		公称流量 Nom. flow ( L/min )	公称压力/Nom.pressure (Mpa)	
	(mm)	(in)		E	F
ZS★_L15※	M22×1.5	1/2	63	16	20
ZS★_L20※	M27×2	3/4	100	16	20
ZS★_L25※	M33×2	1	160	16	20
工作油液 Hydranlic Oil	温度范围 Tem.range(°C)		粘度范围 Visc.range(mm <sup>2</sup> /s)	过滤精度 Filtrating accuracy(μm)	
	-20~+80		10~400	≤10	

注：油液最高污染等级：按GB/T14039之19/16。

Note: maximum permissible degree of contamination of the oil is according to GB/T14039-19/16.

★ 表示设计序号。※表示压力等级。

★ Inducates design number. ※Inducates prossure grade.

### 机能符号/SPOOLFUNCTION SYMBOLS

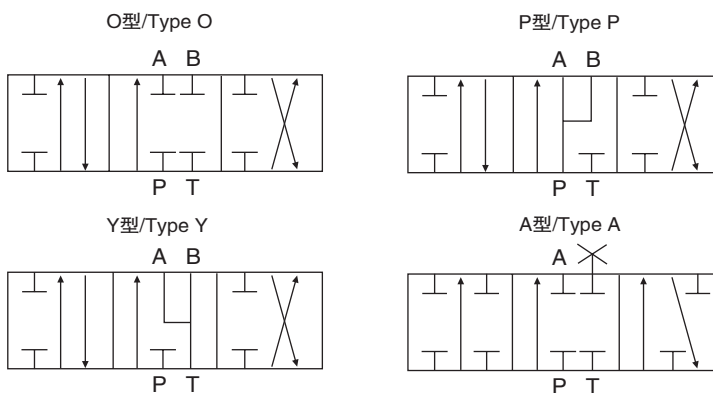

# ZS1 系列分片式多路阀

## ZS1 Series Sectional Directional Control Valve

### 用途与特征/APPLICATIONS&FEATURES

ZS1系列多路换向阀带有先导式安全阀和单向阀，油路形式为并联油路。该阀结构简单，泄露量小，安全阀启闭性好，滑阀机能有O、P、Y、A、几种形式。定位方式有弹簧复位和钢球定位两种。

ZS1 series sectional directional control valves consist of pilot operated relief valve and check valve with parallel oil circuit. Its features are simple in structure, small in leakage and good in stopping property of relief valve. The spool functions include the forms of O, P, Y and A. The positioning and returning modes include spring return and ball locking.

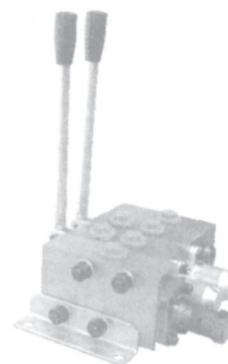

### 性能参数/SPECIFICATIONS

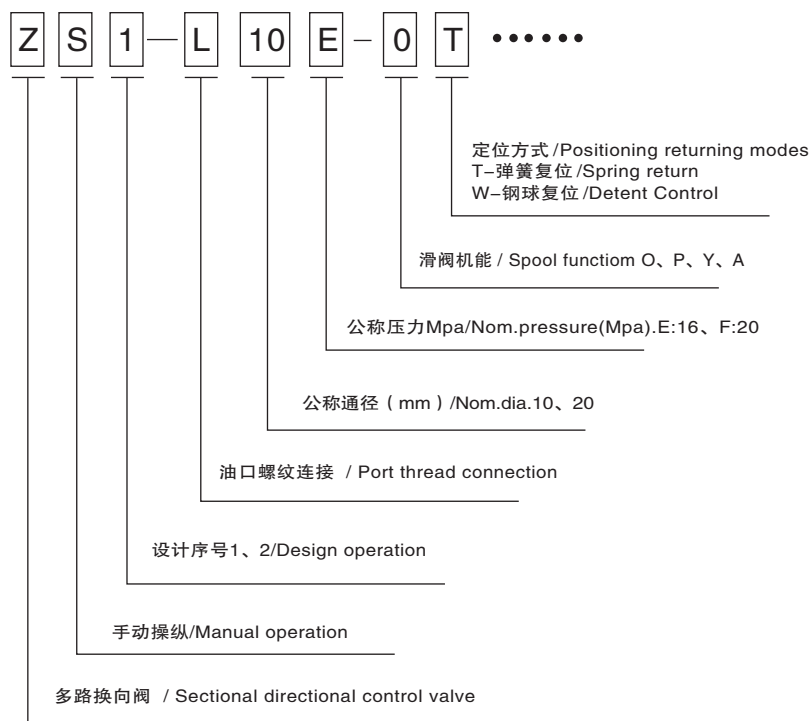

注：订货有特殊要求者，请与销售顾问联系。

Notes: Special features not listed on can often be made to your specifications. Please consult your sales representative.

# ZS1-L10系列分片式多路阀

## ZS1-L10 Series Sectional direction valve

### 型号举例/MODEL EXAMPLES

ZS1-L10※-OT.OW

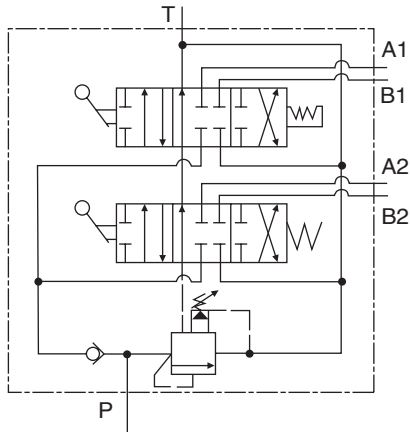

ZS1-L10※-YT.OW

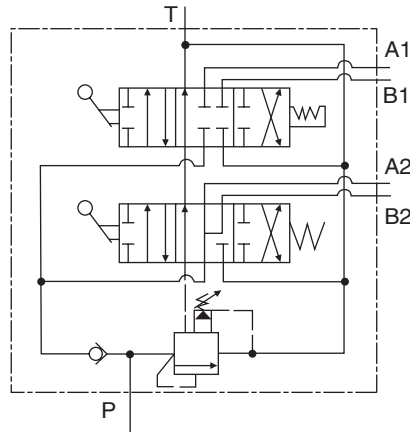

### ZS1-L10外形安装连接尺寸/MODEL ZS1-L10 DIMENSIONAL DATA

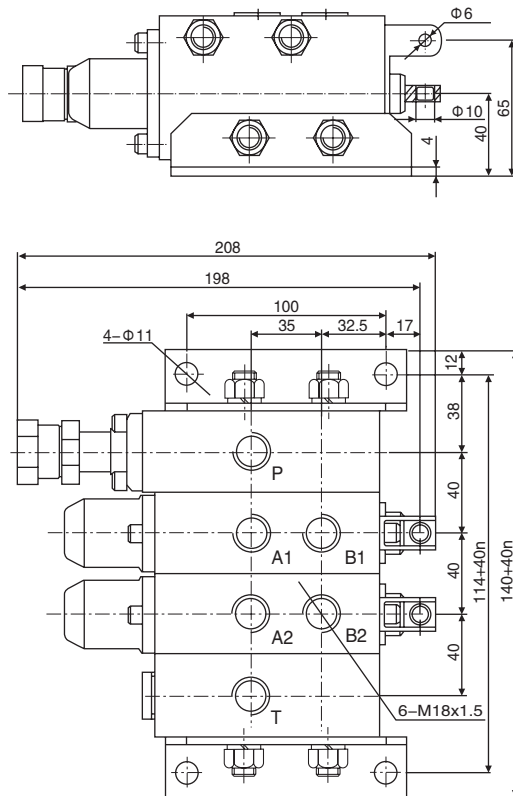

注：n表示多路换向阀连片数  
Note: n is the number of direction valve pieces.

# ZS1-L15系列分片式多路阀

## ZS1-L15 Series Sectional Directional Control Valves

### 用途与特征/APPLICATIONS&FEATURES

ZS1系列多路换向阀带有先导式安全阀和单向阀，油路形式为并油路。该阀结构简单，泄露量小，安全阀启闭性好，滑阀机能可有O、P、Y、A、几种形式。定位方式有弹簧复位和钢球定位两种。

Model ZS1 sectional valves with pilot relief valve and inner check valves are in simple construction, lower inner leakage and good quality relief valve. The spool functions is O, P, Y, A. The spring return and detent control are available for options.

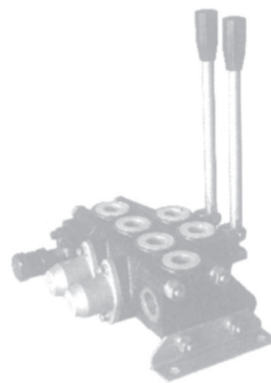

### 性能参数/SPECIFICATIONS

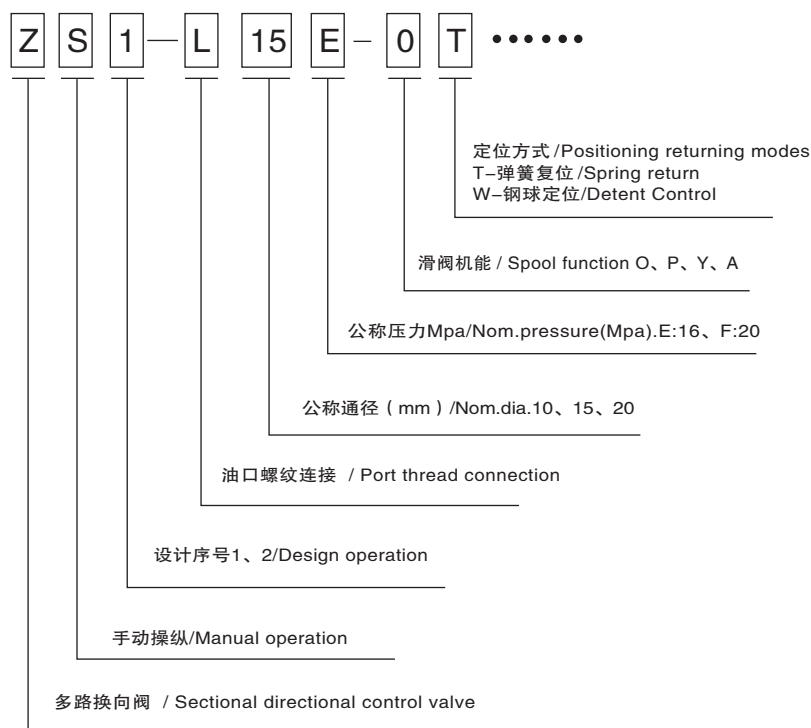

注：订货有特殊要求者，请与销售顾问联系。

Note: Special features not listed can often be made to your specifications. Please consult your sales representative.

# ZS1-L15系列分片式多路阀

## ZS1-L15 Series Sectional Directional Control Valves

### ZS1-L15外形安装连接尺寸/MODEL ZS1-L15 DIMENSIONAL DATA

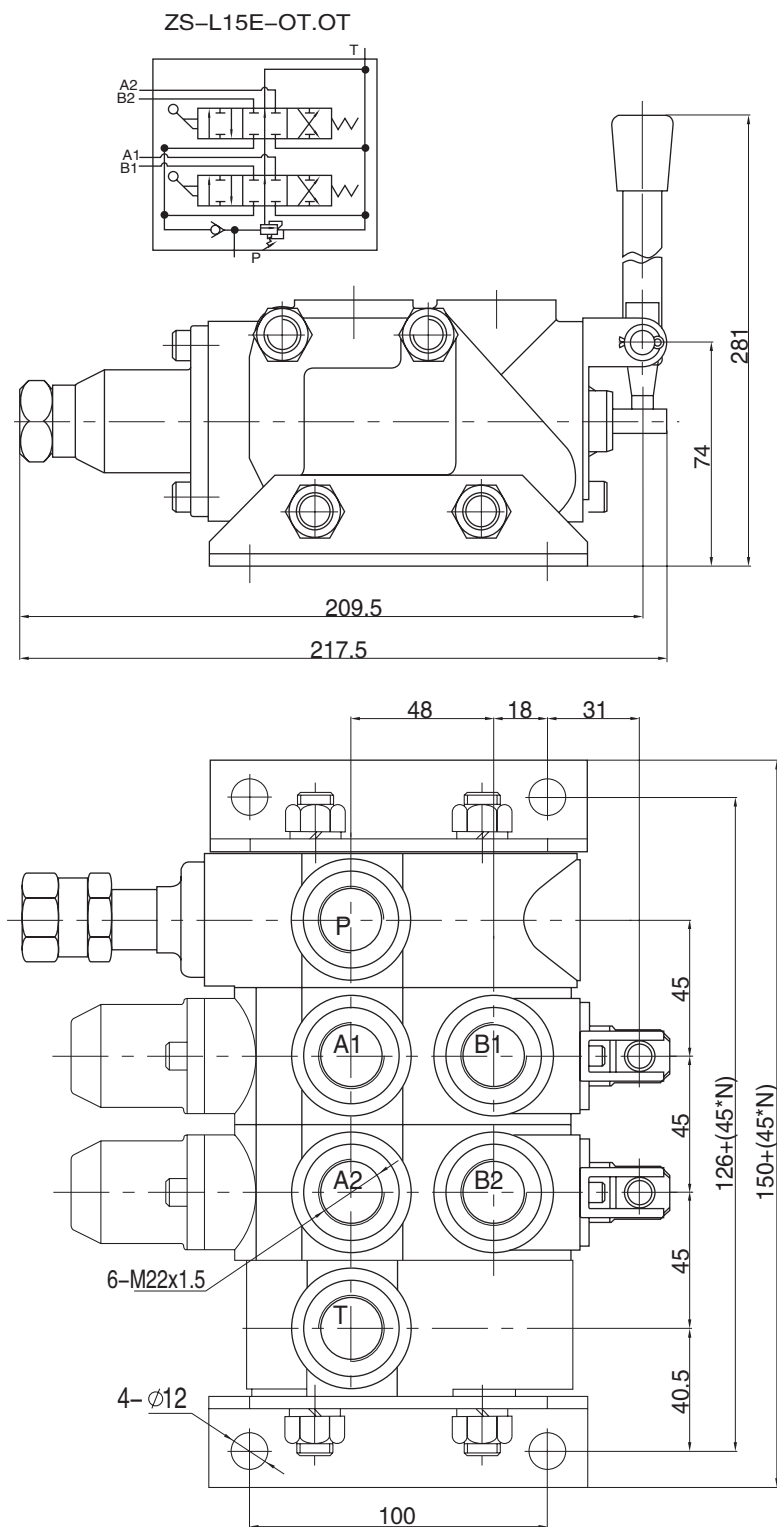

b50

ZS1-L15系列分片式多路阀SDCV

# ZS3系列分片式多路阀

## ZS3 Series Sectional Directional Control Valve.

### 用途与特征/APPLICATIONS&FEATURES

ZS3系列多路换向阀是在ZS1系列多路换向阀的基础上改进设计的。主要是对ZS3系列多路换向阀外形进行了流线设计，使阀体外形尺寸减小，阀体重量减轻，其安装尺寸、油路形式、滑阀机能、定复方式均与ZS3系列多路换向阀相同。

ZS3 series multiple directional control valves are improved on the basis of the ZS1 series valves. It's mainly changed in the streamline design of outline of figure to reduce the size and weight. Its mounting dimension, form of oil circuit, spool function, and positioning and returning modes are the same as that of the ZS3 valves.



### 型号说明/MODEL CODE

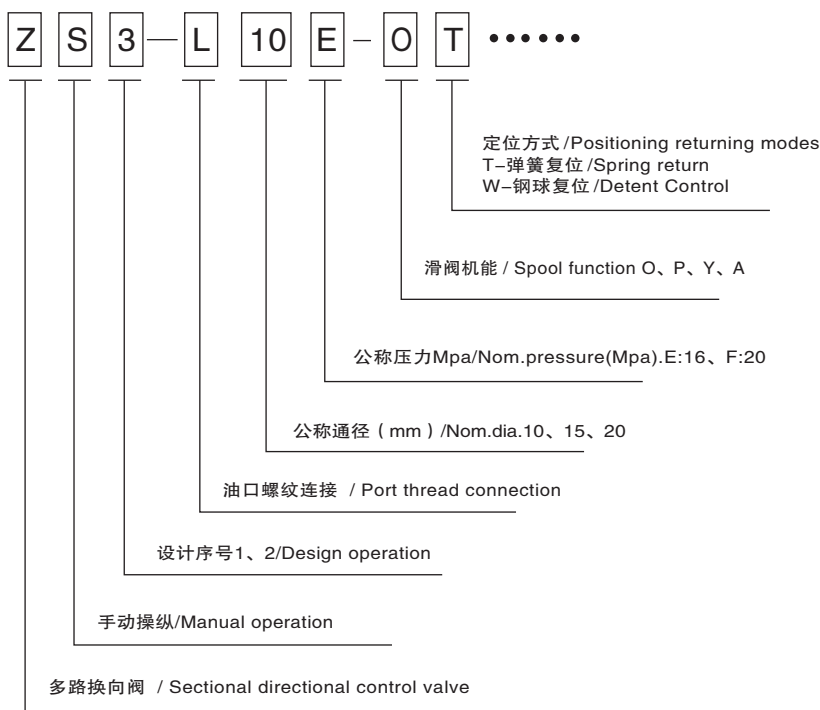

# ZS3-L10系列分片式多路阀

## ZS3-L10 Series Sectional Directional Control Valves

### 型号举例/MODEL EXAMPLES

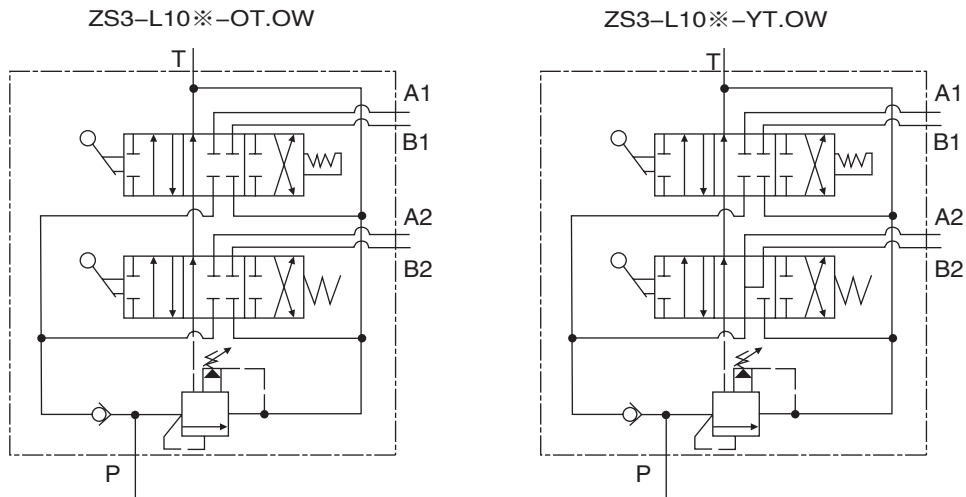

### ZS3-L10外形安装连接尺寸 / ZS3-L10 DIMENSIONAL DATA

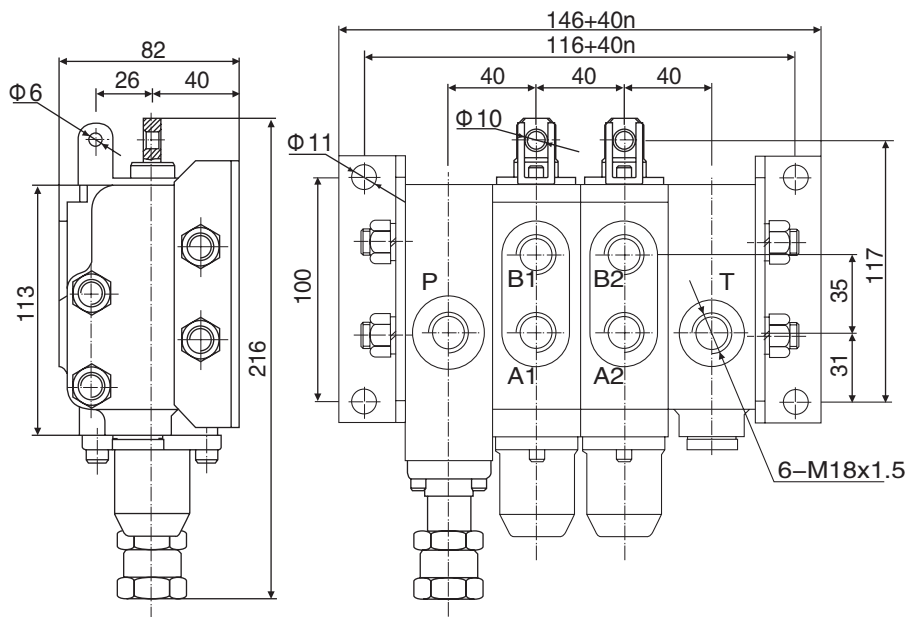

注：n表示多路换向阀连片数  
Note: n is the number of direction valve pieces.



# ZS4-L25 系列分片式多路阀

## ZS4-L25 Series Sectional Directional Control Valves

### 用途与特征/APPLICATIONS&FEATURES

ZS4-L25系列多路换向阀是由进油体、回油体和换向阀体组合而成,它具有结构紧凑、工作压力高、性能可靠等特点,此阀最大特点是该用了直动式安全阀,解决了以往先导式安全阀容易堵死的缺点,使得多路阀的抗污性大大提高。广泛用于叉车、装载机、挖掘机、起重机、压路机等工程机械及矿山、轻工、环卫、农机等行业。用以改变液流方向,实现多个执行机构的集中控制。我公司生产的该型号多路阀可安装双操作手柄,极大地方便了用户的使用操作。

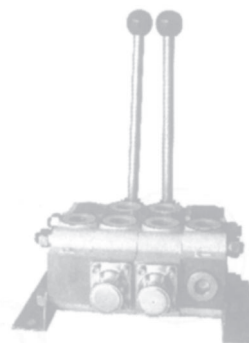

ZS4-L25 series sectional directional hydraulic control valve is assembled with slice, outlet slice and working slice. It has such characteristics as tight structure, high working pressure and reliable working performance. The main characteristic is to change pilot safety valve into direct-acting safety valve in case of blocking and to improve the resistant-contamination. This kind of valve is widely used in engineering machinery, mining, light industry, environmental and agricultural machinery, such as forklift, loading trucks, excavators, cranes and road rollers. It's used to change flow direction and to achieve the integrated control over several executive mechanism. It may be fixed with double operational hand shank, which is convenient for users.

### 性能参数/SPECIFICATIONS

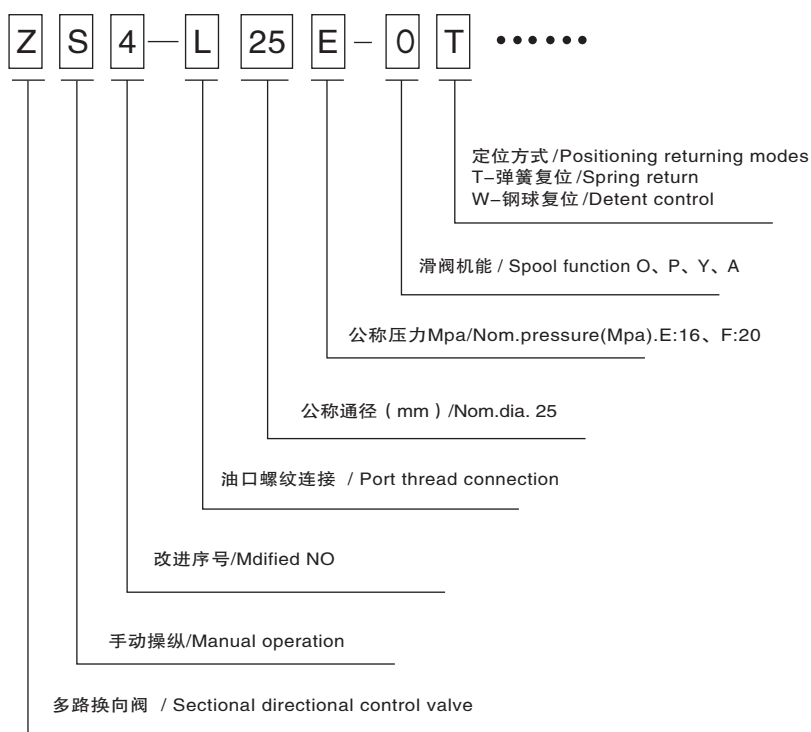

注: 订货有特殊要求者, 请与销售顾问联系。

Note: Special features not listed can often be made to your specifications. Please consult your sales representative.

b54

ZS4-L25系列分片式多路阀SDCV

# ZS4-L25 系列分片式多路阀

## ZS4-L25 Series Sectional Directional Control Valves

### ZS4-L25外形安装连接尺寸/MODEL ZS4-L25 DIMENSIONAL DATA

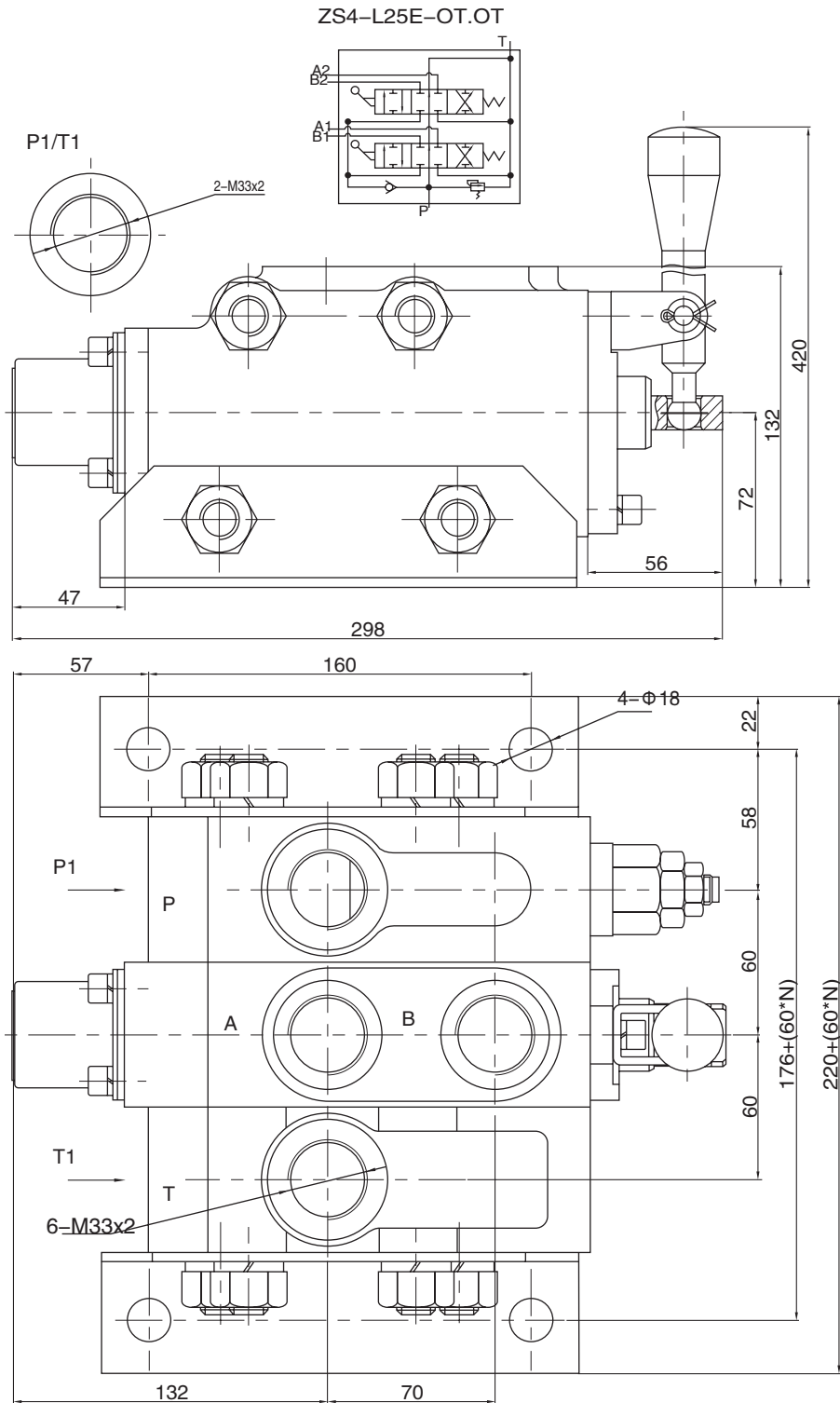

# DL系列分片式多路阀

## DL Series Sectional Directional Control Valves

### 用途与特征/APPLICATIONS&FEATURES

DL系列多路换向阀是由多个换向阀和安全阀及各种附加组合阀组合而成。它具有工作压力高、结构紧凑、安全阀性能好、可靠性高、不易外漏、通用性好等特点。它主要用于ZL40以下装载机、小型挖掘机等工程机械的液压系统中，也用于起重运输机械、矿山机械、农业机械或其他机械的液压系统中，实现多个执行机构的集中控制。

该系列多路阀每连都带单向阀。根据用户需要，可在任一工作腔和回油腔之间安装过载阀或补油阀。能够组成并联、串联或串并联复合油路，并有多种滑阀机能、定位、复位方式及控制方式，也可利用过桥阀体或外接油口向其它机构提供油源，广泛地满足了不同主机的需要。

DL series sectional directional control valve consists of several check valves, safety valves and some additional combination valves. It has such characteristics as high working pressure, compact structure, good performance of relief valve, high reliability, uneasy leakage, good commonality, etc. It's mainly used in hydraulic systems of engineering machinery such as ZL40 loaders, mini-excavators, etc. The valves can also be used in hydraulic systems of crane and carriage machinery, mining machinery, agricultural machinery and so on to execute integrated control over several executive mechanism.

The DL series sectional directional control valves have a check valve in each piece. The overload valve and or make up valve can be installed between any working cell and returning cell according to the clients' demand. The circuit can be parallel connection, serial connection or compound connection. There are several spool functions, positioning and returning modes and control modes. Oil may be also supplied to other mechanism through interim valve or external oil port, so as to meet a variety of different customers' needs.

### 性能参数/SPECIFICATIONS

型号 Model	公称通径 Nom. Dim (mm)	最大压力 Max. pressure (Mpa)	公称流量 Nom. flow (L/min)	允许背压 Allowabl Back pressure (Mps)	油液 Hydraulic Oil			计算重量 Calculated weight(Kg)		
					温度范围 Tem.rang (°C)	粘度范围 Visc.rang (mm <sup>2</sup> /s)	过滤精度 Filtrating accuracy (μm)	1 连 One piece	2 连 Two piece	n 连 n piece
DL15	15	31.5	63	≤2.5	-20~+80	10~400	≤10	12.4	17.7	7.1+ 5.3n
DL20	20		100					20	27.5	12.5+ 7.5n
DL25	25		160					29.2	42.8	15.6+ 13.6n

型号 Model	公称通径 Nom. Dim (mm)	先导液控压力 Pilot pressure (Mpa)	最小控气压力 Min.air pressure (Mpa)	安全阀及过载阀或二次压力阀的调压范围 Pressure range of relief valve, overload valve or secondary pressure valve (Mpa)				补油阀开启压力 Opening pressure of the make up valve (Mpa)
DL15	15	0.5~2.5	0.5	4~16	6~20	8~25	10~32	≤0.2
DL20	20							
DL25	25							

注：油液最高污染等级：按GB/T14039之19/16。

Note: Max. permissible degree of contamination of the oil is according to GB/T14039-19/16.

b56

DL系列分片式多路阀SDCV

# DL系列分片式多路阀

## DL Series Sectional Directional Control Valves

压力分级及进回油口位置/PRESSURE GRADE、INLET AND OUTLET POSITIONS 表1/Table 1

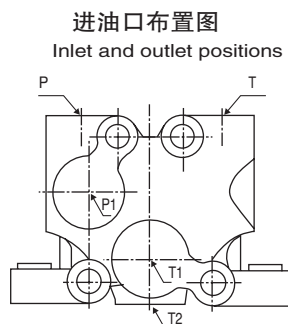

代号 Codet	压力分级 Pressure grade	安全阀压力 Safety valve pressure			
		16MPa	20MPa	25MPa	32MPa
P T		E	F	G	H
P1 T		E1	F1	G1	H1
P T1		E2	F2	G2	H2
P1 T2		E3	F3	G3	H3
P1 T1		E4	F4	G4	H4
P T2		E5	F5	G5	H5
P P1 T		E6	F6	G6	H6

注：P1为测压口时尺寸为M14X1.5  
Note:P1-measuring pressure port,dim.:M14X1.5

滑阀机能及油路形式/SPOOL FUNCTION AND OIL CIRCUIT MODE

表2/Table 2



油路形式 Oil circuit modet	阀体形式 Valve body mode	滑阀机能 S pool function	代号 Code	机能符号 Spool fuction symbols
并联 Parallel	并联 阀体 Parallel valve baady	O	O	
		Y	Y	
		A	A	
		Q	Q	
		D	D	
		P	P	
串联 Serial	串联 阀体 Serial valve body	M	M	
		K	K	
串并联 Serial & parallel combine	串并联阀体 Serial valve body	O	Q	
		Y	Y	
		A	A	
		Q	Q	
		D	D	
		P	P	

# DL系列分片式多路阀

## DL Series Sectional Directional Control Valves

A、B口带的辅助阀/AUXILIARY VALVE ON PORTS A & B

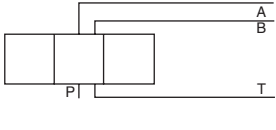
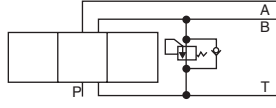
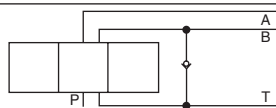
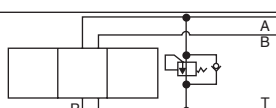
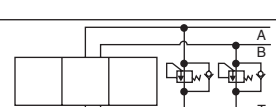
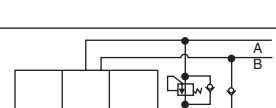
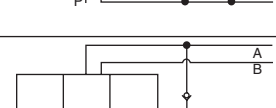
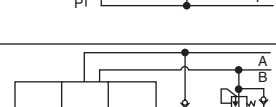
表3/Table 3

代号 Code		液压图形符号 Hydraulic graphic symbols	附带的辅助阀 Auxiliary valve	
过载阀压力与进油口安全阀压力相同 The overload valve has the same pressure as the relief valve at the inlet port	过载阀压力与进油口安全阀压力不相同 The overload valve has different pressure from the relief valve at the inlet port		A□	B□
无/No	无/No		无/No	无/No
1	1		无/No	过载阀 Overload valve
2	2		无/No	补油阀 Make up valve
3	3		过载阀 Overload valve	无/No
4	4		过载阀 Overload valve	过载阀 Overload valve
5	5		过载阀 Overload valve	补油阀 Make up valve
6	6		补油阀 Make up valve	无/No
7	7		补油阀 Make up valve	过载阀 Overload valve
8	8		补油阀 Make up valve	补油阀 Make up valve

b58

DL系列分片式多路阀SDCV

# DL系列分片式多路阀

## DL Series Sectional Directional Control Valves

控制及定位复位方式/CONTROLLING POSITIONING AND RETURNING MODES 表4/Table 4

序号 Sequential number	控制方式 Montral mode	代号 Code	定位复位方式 Positioning and returning modes	图形符号 Graphical symbols
1	手动控制 Mandual control	T	三位弹簧复位 Three positions spring returning	
2		W	三位钢珠复位 Three positions ball locking	
3		$\frac{W}{-}$	四位钢珠复位 Four positions ball locking	
4	手动气动控制	Q	三位手动控制 Three position mandnal control	
5	液压控制 Hydraulic control	U	三位弹簧复位 Three positions spring returning	

## DL-※15系列多路换向阀 DL-※15 Series Sectional Directional Control Valve

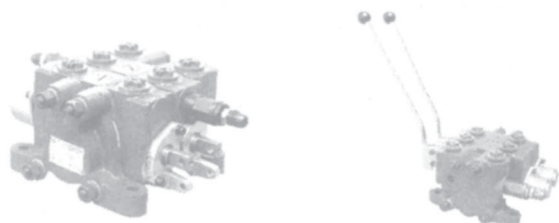

### 用途与特征/APPLICATIONS&FEATURES

DL-※15系列多路换向阀是由单向阀、安全阀、进油体、回油体和多个换向阀片组合而成的组合阀，以手动换向阀为主。它具有结构紧凑、工作压力高、性能优异、工作可靠等特点。油路采用并联油路。有多种滑阀技能供系统需要。阀杆复位方式采用手动换向到弹簧自动复位或钢珠定位。阀片内部设置单向阀，以防止油液倒流。进油阀片带有溢流阀，以控制整个系统压力。根据用户需要，换向阀片两端可装有超载阀以满足不同执行机构负载需要。该阀广泛用子叉车、环保车等工程机械的液压系统。

DL-※15 series sectional directional control valve is assembled with check valve, safety valve, inlet slice, outlet slice and working slices. It has such characteristics as compact structure, high working pressure, good performance, high reliability, etc. The circuit is parallel connection. There are many spool functions options. The positioning and returning modes of the valve handle include spring returning and detent control. There is a check valve inside the working slice in case of back flow. There is a relief valve in the inlet slic to control the whole system pressure. The overload valves are available to be assembled on A, B port to meet different requests. The valve is widely used in such hydraulic systems of engineering machinery as forklift, environmental trucks, etc.

# DL-L15 系列分片式多路阀

## DL-L15 Series Sectional Directional Control Valves

### 型号说明/MODEL CODE

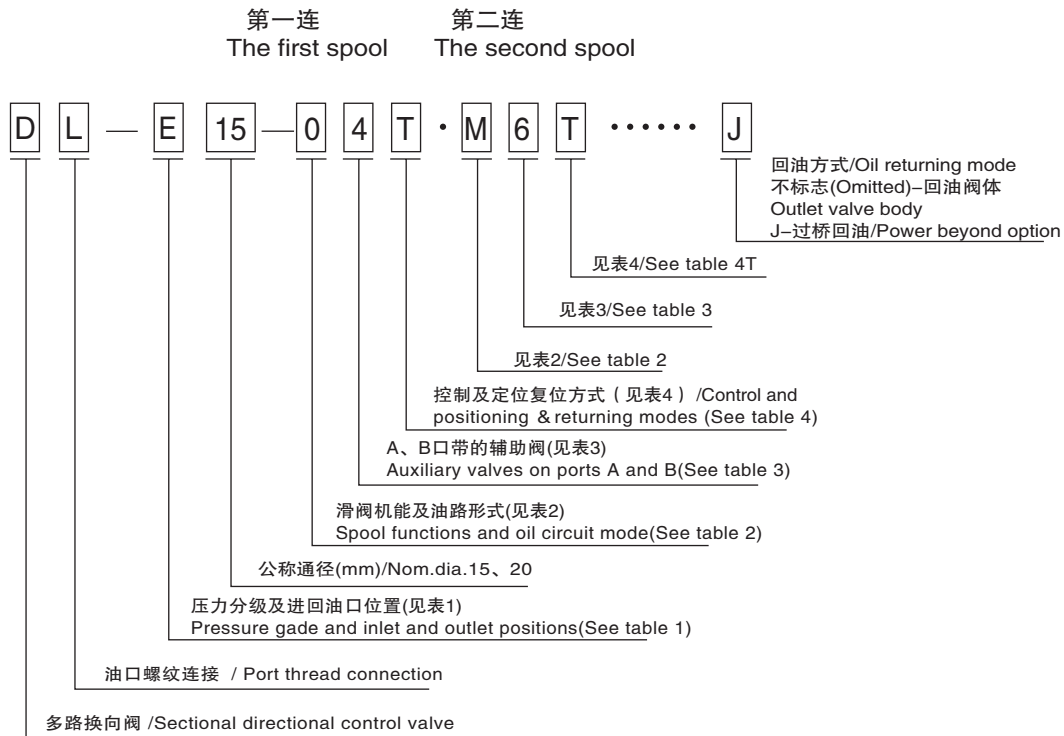

注：订货有特殊要求者，请与销售顾问联系。  
Note: Special features not listed can often be made to your specifications. Please consult your sales representative.

### 型号举例/MODEL EXAMPLES

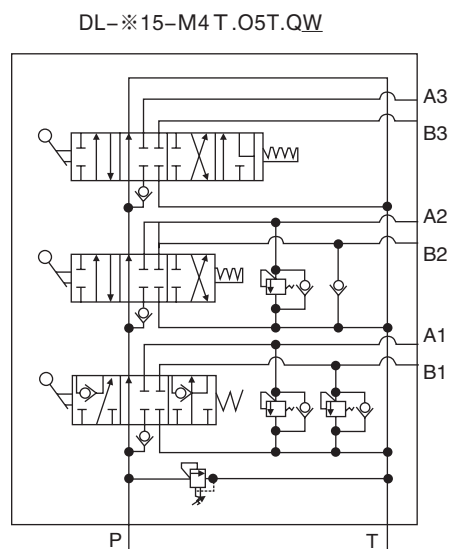
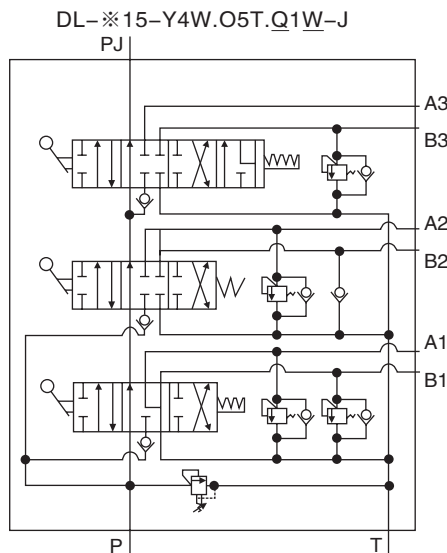

# DL-L15 系列分片式多路阀

## DL-L15 Series Sectional Directional Control Valves

### DL-L15外形安装连接尺寸/MODEL DL-L15 DIMENSIONAL DATA

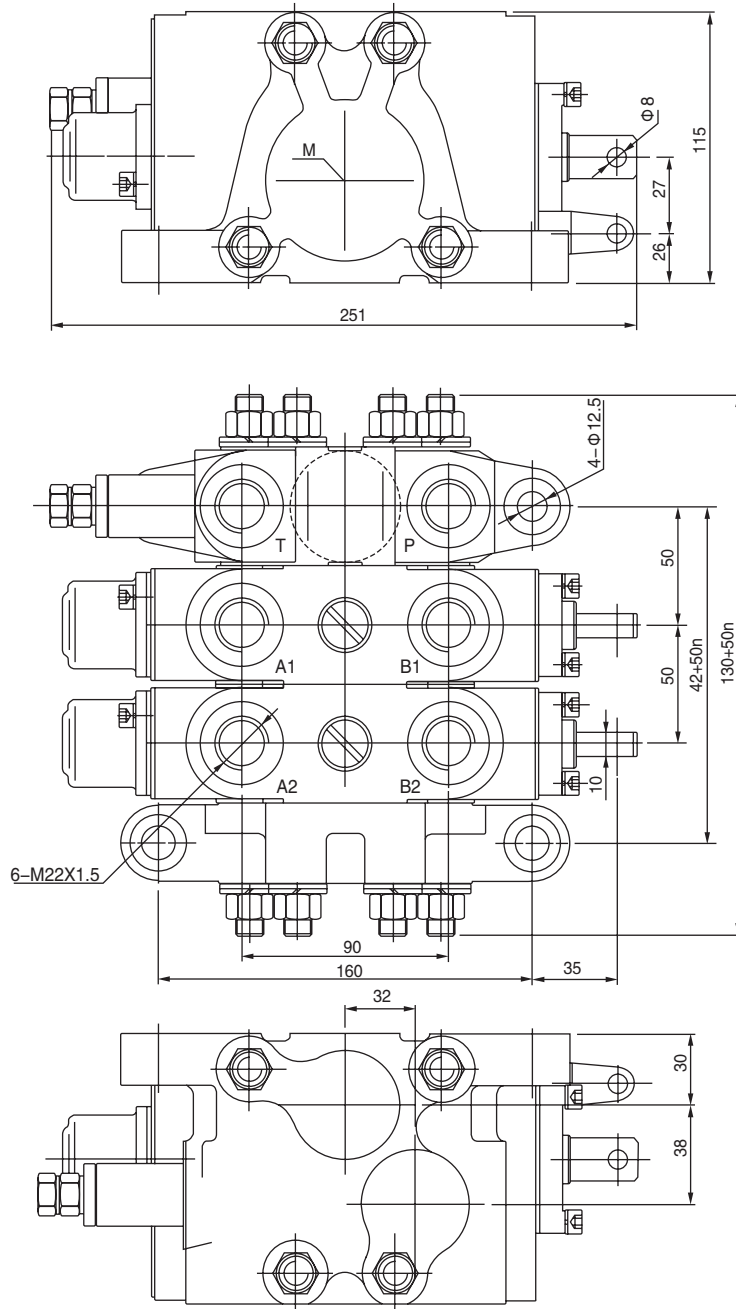

注: M为过桥油口连接尺寸,n表示多路换向阀连数片  
 Note:M indicates the connecting dimension for interim valve port and n is the number of direction valve pieces.

b61

DL-L15系列分片式多路阀SDCV

# SQDL-L15 手气控分片式多路阀

## SQDL-L15 Series Manual-Pneumatic Control Valves

### 用途与特征/APPLICATIONS&FEATURES

SQDL-L15气控系列多路阀是在DL-L15手动控制系列的基础上改进而来。它主要是改变了手动换向阀的操纵机构，在手动的基础上增加了气动控制，能够更好地实现远程控制。SQDL-L15气控系列多路阀的回油端设置了压力输出口，可与其他液压元件串联使用。该阀具有结构紧凑，工作压力高，性能好，工作可靠，可实现多个执行机构的近、远程控制的优点。根据用户需要，换向阀的操纵机构可以和普通手动控制进行任意组合。该阀广泛应用于工程机械、环卫机械、矿山机械和其他机械的液压系统。

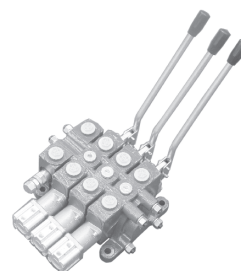

SQDL-L15 series pneumatic control valves are developed on SQDL-L15 manual control valves. It changed the control way of these valves, especially, it can be controlled by remote control with the pneumatic control way. The power beyond function is on the SQDL-L15 series, it is able to be connected with other hydraulic valves in series. The features of SQDL-L15 pneumatic control valves are compact construction, high working pressure, better functions, reliable working, remote controlling and etc. Besides that, the manual control can be used with the pneumatic control together. The valves are widely used on mechanical machines, sanitation machines, mining machines and other machines' hydraulic systems.

- ◆ 内置单向阀：阀体内置单向阀，防止油液倒流  
Inner check valve: The check valve inside the valve body is to insure the hydraulic oil not to be returned.
- ◆ 内置安全阀：阀体内置溢流阀，可调节控制系统压力  
Inner relief valve: The relief valve inside the valve body is able to adjust the hydraulic system working pressure.
- ◆ 油路形式：并联油路，带压力输出口  
Oil way: Parallel circuit, with power beyond.
- ◆ 控制方式：气控换向，也可手动换向  
Control Way: pneumatic control, manual control
- ◆ 阀体结构：分片结构，1-10联任意组合  
Valve construction: sectional construction, 1-10 levers are available to assembled as you requests.
- ◆ 阀杆机能：O、A、Y等  
Spool Function: O, A, Y etc.
- ◆ 附加阀：换向阀的两端，根据需要可增加过载阀或者补油阀  
Options of valves: The overload valves and make-up valve can be fitted on the two ends of the valve body.

### 型号说明/MODEL CODE

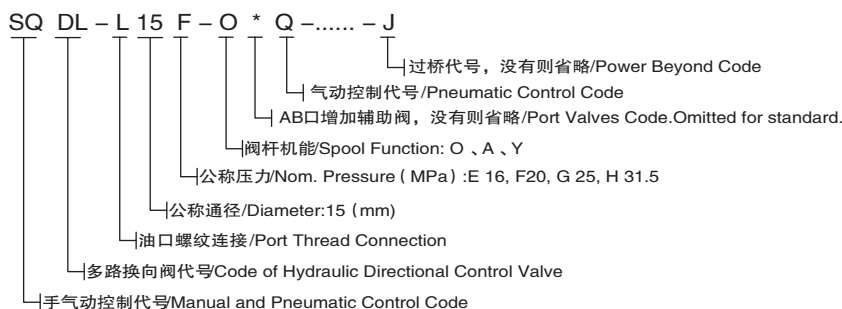

### 技术参数/PARAMETERS

公称压力 (MPa) Nom. Pressure	最大压力 (MPa) Max. Pressure	公称流量 (L/min) Nom. Flow rate	中位背压 (MPa) Back Pressure	工作油液 hydraulic oil		
				温度范围 (°C) Tem.rang	粘度范围 (mm <sup>2</sup> /S) Visc.rang	过滤精度 (μm) filtrating accuracy
20	31	63	≤1	-20 ~ +80	10 ~ 400	≤10

# SQDL-L15 手气控分片式多路阀

## SQDL-L15 Series Manual-Pneumatic Control Valves

### SQDL-L15外形安装连接尺寸/MODEL SQDL-L15 DIMENSIONAL DATA

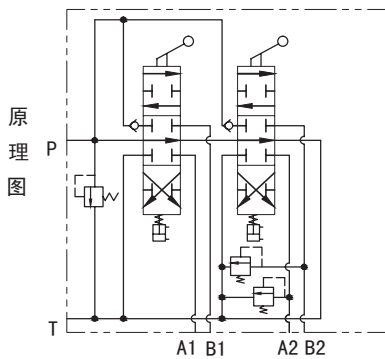
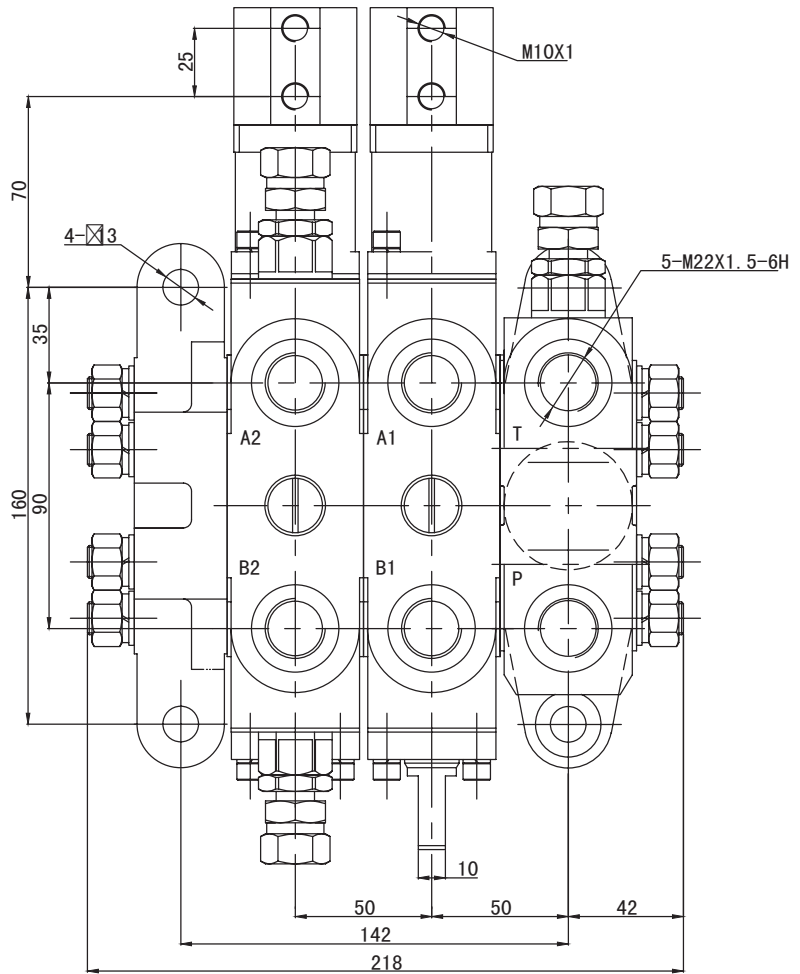
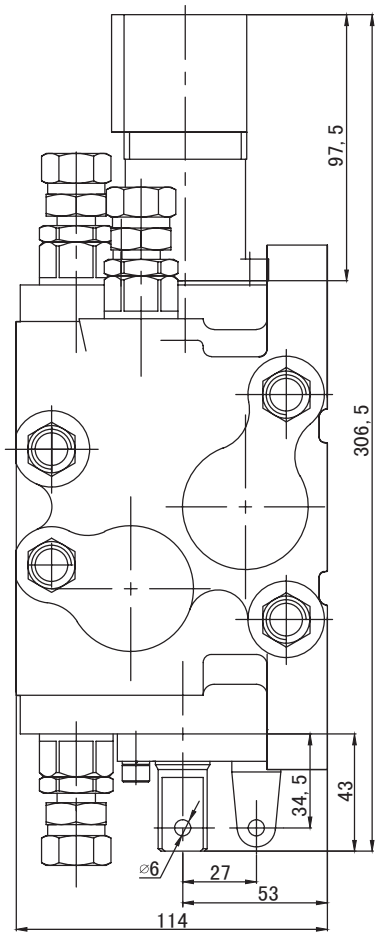

主要技术参数:

1. 公称流量63L/min,
2. 公称压力16MPa.

b63

SQDL-L15手气控分片式多路阀SDCV

# YDL-L15液控片式多路阀

## YDL-L15 Series Hydraulic Control Directional Control Valves

### 用途与特征/APPLICATIONS&FEATURES

YDL-L15先导液控系列多路阀是在DL-L15手动控制系列的基础上开发而来。它主要是由手动换向阀改进为液控先导控制，解决了手动操纵力大的缺点，并且能够地实现远程控制。YDL-L15系列多路阀的回油端设置了压力输出口，可与其他液压元件串联使用。该阀具有结构紧凑，工作压力高，性能好，工作可靠，可实现多个执行机构的远程控制的优点。该阀广泛应用于工程机械、环卫机械、矿山机械和其他机械的液压系统。

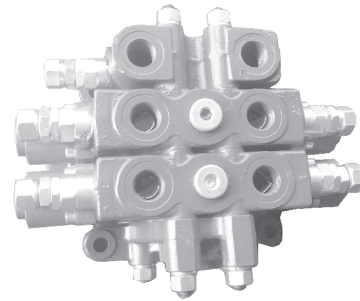

YDL-L15 series pilot hydraulic directional control valves are developed on DL-L15 manual control valves. It changed the control way from manual to pilot hydraulic which improves the heavy manual control situation. Especially, it can be controlled by remote control with the pilot hydraulic control way. The power beyond function is on the YDL-L15 series, it is able to be connected with other hydraulic valves in series. The features of YDL-L15 pilot hydraulic control valves are compact construction, high working pressure, better working performance, reliable working, remote controlling and etc. Besides that, it realize to control many working functions by remote control. The valves are widely used on mechanical machines, sanitation machines, mining machines and other machines' hydraulic systems.

- ◆ 内置单向阀：阀体内置单向阀，防止油液倒流  
Inner check valve: The check valve inside the valve body is to insure the hydraulic oil not to be returned.
- ◆ 内置安全阀：阀体内置溢流阀，可调节控制系统压力  
Inner relief valve: The relief valve inside the valve body is able to adjust the hydraulic system working pressure.
- ◆ 油路形式：可实现并联、串联或串并联复合油路，带压力输出口  
Oil way: Parallel circuit, series circuit and composite with both circuit with power beyond.
- ◆ 控制方式：气控换向，也可手动换向  
Control Way: pneumatic control, manual control
- ◆ 阀体结构：分片结构，1-10联任意组合  
Valve construction: sectional construction, 1-10 levers are available to assembled as you requests.
- ◆ 阀杆机能：O、A、Y等  
Spool Function: O,A,Y etc.
- ◆ 附加阀：换向阀的两端，根据需要可增加过载阀或者补油阀  
Options of valves: The overload valves and make-up valve can be fitted on the two ends of the valve body.

### 型号说明/MODEL CODE

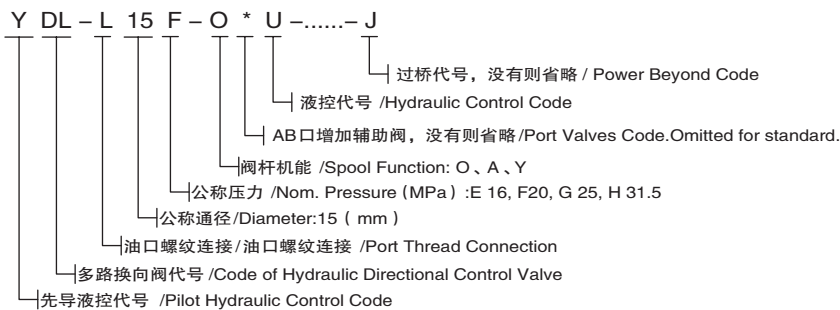

### 技术参数/PARAMETERS

公称压力 ( MPa ) Nom. Pressure	最大压力 ( MPa ) Max. Pressure	公称流量 ( L/min ) Nom. Flow rate	中位背压 ( MPa ) Back Pressure	工作油液 hydraulic oil		
				温度范围 ( °C ) Tem.rang	粘度范围 ( mm <sup>2</sup> /S ) Visc.rang	过滤精度 ( μm ) filtrating accuracy
20	31	63	≤1	-20 ~ +80	10 ~ 400	≤10

# YDL-L15液控片式多路阀

## YDL-L15 Series Hydraulic Control Directional Control Valves

### YDL-L15 外形安装连接尺寸/MODEL YDL-L15 DIMENSIONAL DATA

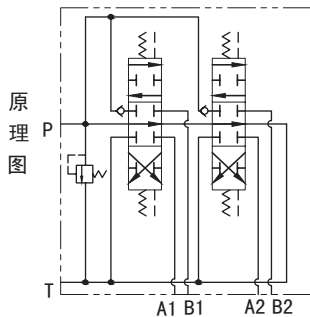
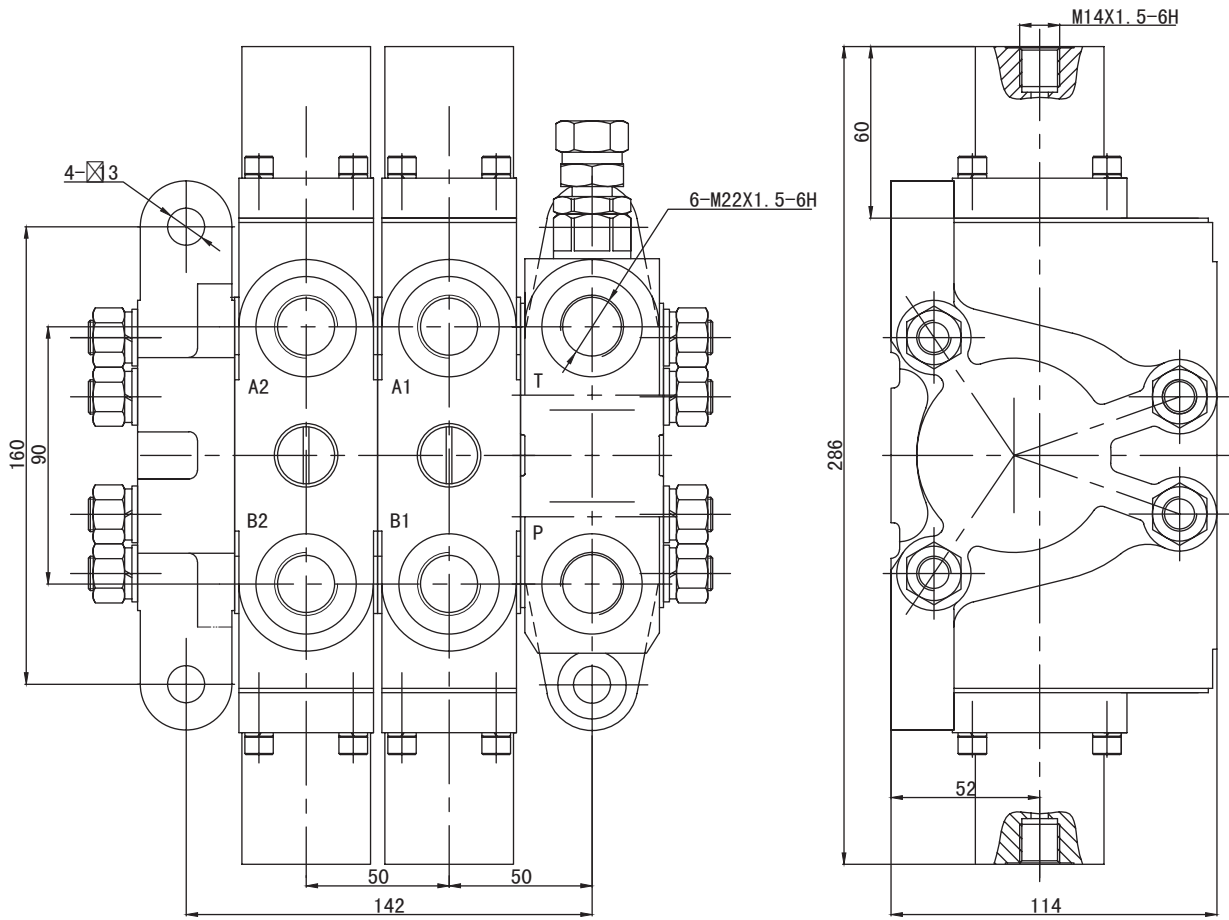

#### 主要技术参数:

1. 公称通径: 15mm,
2. 公称流量: 63L/min,
3. 额定压力: 20MPa

原理图

b65

YDL-L15液控片式多路阀SDCV

# DL-20 系列分片式多路阀

## DL-20 Series Sectional Directional Control Valves

### 用途与特征/APPLICATIONS&FEATURES

DL-20L系列多路换向阀是由单向阀、安全阀、进油体、回油体和多个换向阀组合起来的组合阀，以手动换向阀为主。它具有结构紧凑、工作压力较高、性能好、工作可靠等特点。广泛应用于叉车、装载机、挖掘机、起重机、压路机等工程机械及矿山、轻工、环卫、农机等行业。用以改变液流方向，实现多个执行机构的集中控制。

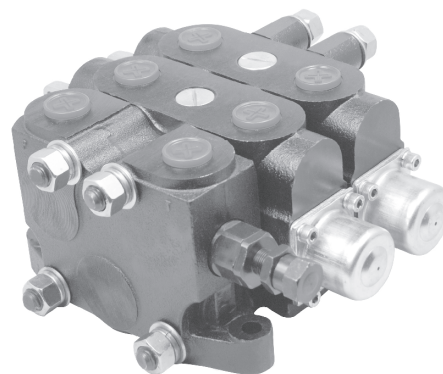

Model DL-L20 sectional directional control valves with mainly manual control are assembled with check valves, relief valves, inlet slice, outlet slice and working slices.

Model DL-L20 features:

- ◆ Inner check valve: The check valve inside the valve body is to insure the hydraulic oil not to be returned.
- ◆ Inner relief valve: The relief valve inside the valve body is able to adjust the hydraulic system working pressure.
- ◆ Oil way: Parallel circuit, series circuit and composite with both circuit with power beyond.
- ◆ Control Way: pneumatic control, manual control
- ◆ Valve construction: sectional construction, 1-10 levers are available to assembled as you requests.
- ◆ Spool Function: O,A,Y etc.
- ◆ Options of valves: The overload valves and make-up valve can be fitted on the two ends of the valve body.

### 型号说明/MODEL CODE

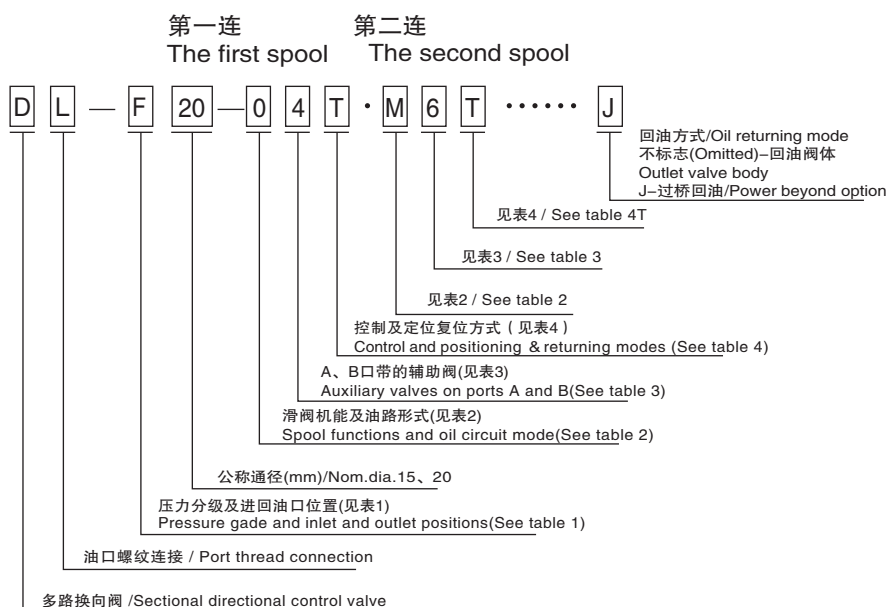

注：订货有特殊要求者，请联系销售顾问。

Note: Special features not listed can often be made to your specifications, please consult your sales representative.

# DL-20系列分片式多路阀

## DL-20 Series Sectional Directional Control Valves

### 型号举例/MODEL EXAMPLES

DL-※20-Y4W. O5T. Q1W-J

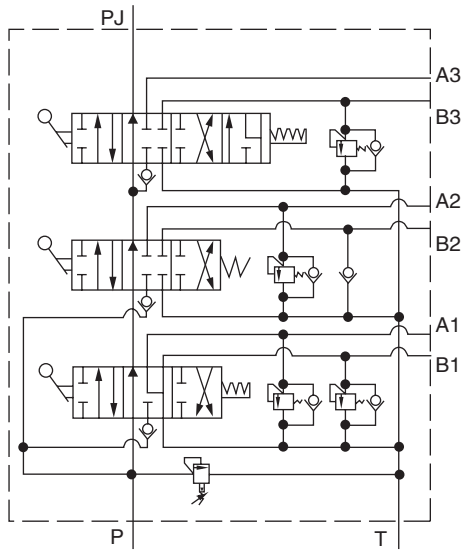

DL-※20-M4T. O5T. QW

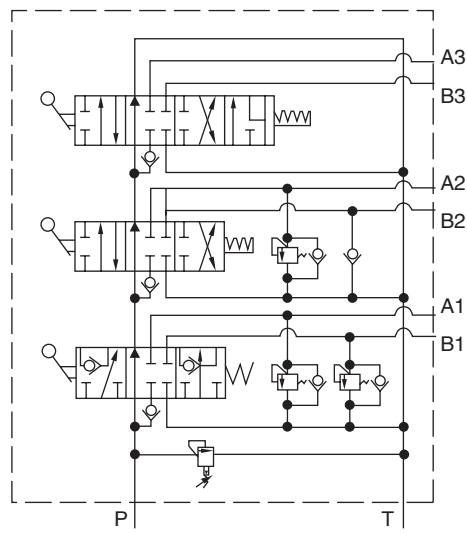

### DL-20外形安装连接尺寸/MODEL DL-20 DIMENSIONAL DATA

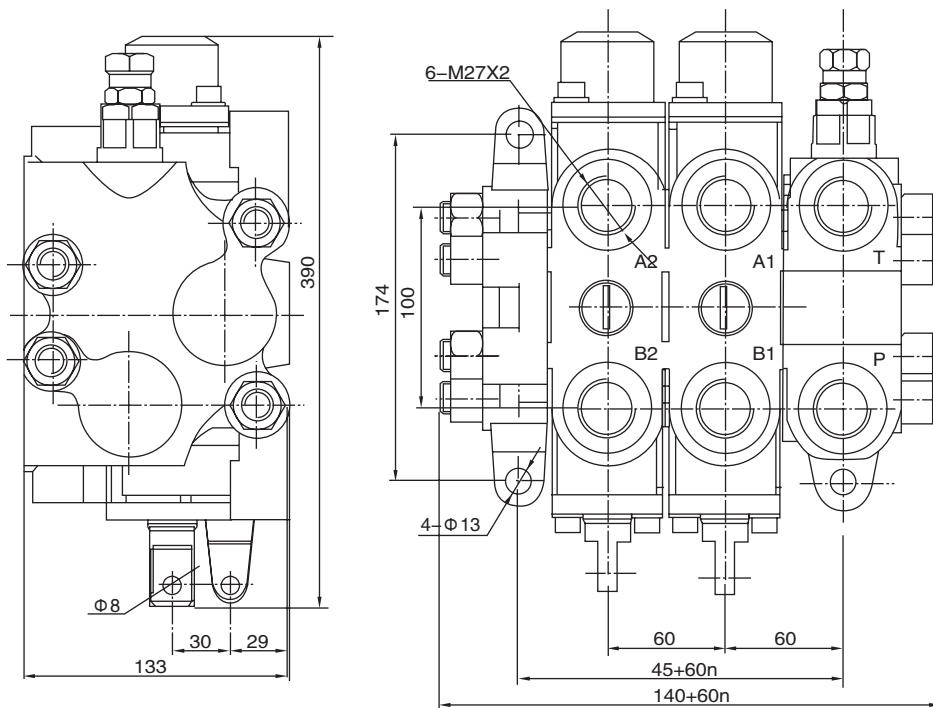

注：n表示多路换向阀连数片  
Note: n is the number of direction valve pieces.

# SQDL-L20手气控分片式多路阀

## SQDL-L20 Manual and Pneumatic Control Valves

### 用途与特征/APPLICATIONS&FEATURES

SQDL-L20气控系列多路阀是在DL-L20手动控制系列的基础上改进而来。它主要是改变了手动换向阀的操纵机构，在手动的基础上增加了气动控制，能够更好地实现远程控制。SQDL-L20气控系列多路阀的回油端设置了压力输出口，可与其他液压元件串联使用。该阀具有结构紧凑，工作压力高，性能好，工作可靠，可实现多个执行机构的近、远程控制的优点。根据用户需要，换向阀的操纵机构可以和普通手动控制进行任意组合。该阀广泛应用于工程机械、环卫机械、矿山机械和其他机械的液压系统。

SQDL-L20 series pneumatic control valves are developed on SQDL-L20 manual control valves. It changed the control way of these valves, especially, it can be controlled by remote control with the pneumatic control way. The power beyond function is on the SQDL-L20 series, it is able to be connected with other hydraulic valves in series. The features of SQDL-L20 pneumatic control valves are compact construction, high working pressure, better functions, reliable working, remote controlling and etc. Besides that, the manual control can be used with the pneumatic control together. The valves are widely used on mechanical machines, sanitation machines, mining machines and other machines' hydraulic systems.

- ◆ 内置单向阀：阀体内置单向阀，防止油液倒流  
Inner check valve: The check valve inside the valve body is to insure the hydraulic oil not to be returned.
- ◆ 内置安全阀：阀体内置溢流阀，可调节控制系统压力  
Inner relief valve: The relief valve inside the valve body is able to adjust the hydraulic system working pressure.
- ◆ 油路形式：并联油路，带压力输出口  
Oil way: Parallel circuit, with power beyond.
- ◆ 控制方式：气控换向，也可手动换向  
Control Way: pneumatic control, manual control
- ◆ 阀体结构：分片结构，1-10联任意组合  
Valve construction: sectional construction, 1-10 levers are available to assembled as you requests.
- ◆ 阀杆机能：O、A、Y等  
Spool Function: O,A,Y etc.
- ◆ 附加阀：换向阀的两端，根据需要可增加过载阀或者补油阀  
Options of valves: The overload valves and make-up valve can be fitted on the two ends of the valve body.

### 型号说明/MODEL CODE

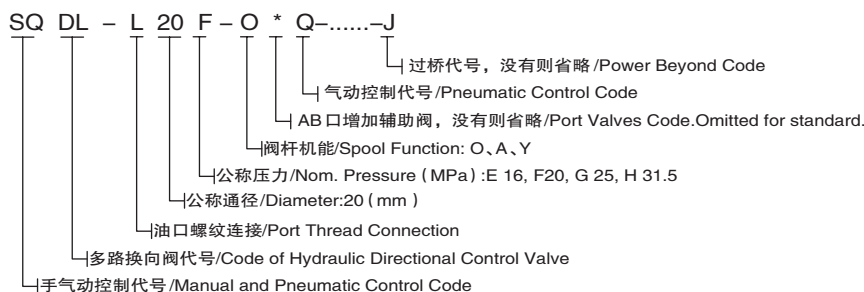

### 技术参数/PARAMETERS

公称压力 (MPa) Nom. Pressure	最大压力 (MPa) Max. Pressure	公称流量 (L/ min) Nom. Flow rate	中位背压 (MPa) Back Pressure	工作油液hydraulic oil		
				温度范围 (℃) Tem.rang	粘度范围 (mm <sup>2</sup> /S) Visc.rang	过滤精度 (μm) filtrating accuracy
20	31	100	≤1	-20 ~ +80	10 ~ 400	≤10

# SQDL-L20手气控分片式多路阀

## SQDL-L20 Manual and Pneumatic Control Valves

### SQDL-L20 外形安装连接尺寸/MODEL SQDL-L20 DIMENSIONAL DATA

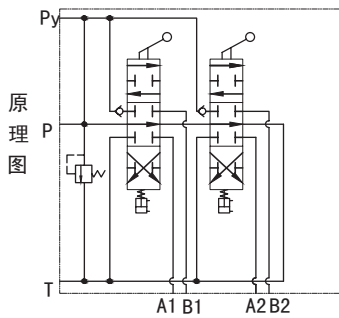
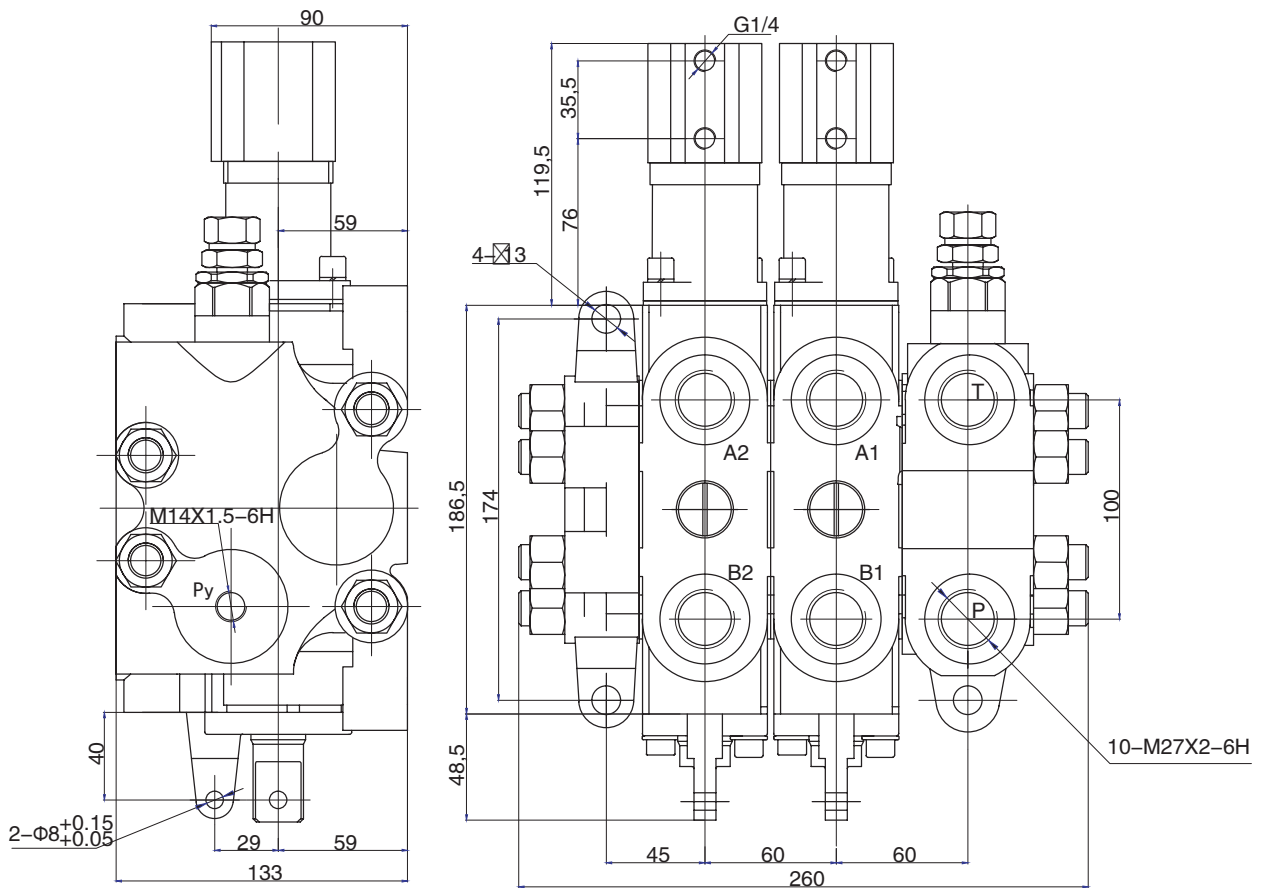

技术参数:

1. 公称流量 100L/min
2. 公称压力 18MPa

# YDL-L20液控片式多路阀

## YDL-L20 series Pilot Hydraulic Directional Control Valves

### 用途与特征/APPLICATIONS&FEATURES

YDL-L20先导液控系列多路阀是在DL-L20手动控制系列的基础上改进而来。它主要是由手动换向阀改进为液控先导控制，解决了手动操纵力大的缺点，并且能够更好地实现远程控制。YDL-L20先导液控系列多路阀的回油端设置了压力输出口，可与其他液压元件串联使用。该阀具有结构紧凑，工作压力高，性能好，工作可靠，可实现多个执行机构的近、远程控制的优点。根据用户需要，换向阀的操纵机构可以和普通手动控制进行任意组合。该阀广泛应用于工程机械、环卫机械、矿山机械和其他机械的液压系统。

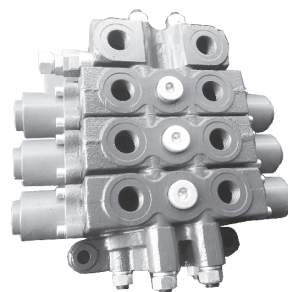

YDL-L15 series pilot hydraulic directional control valves are developed on DL-L15 manual control valves. It changed the control way from manual to pilot hydraulic which improves the heavy manual control situation. Especially, it can be controlled by remote control with the pilot hydraulic control way. The power beyond function is on the YDL-L15 series, it is able to be connected with other hydraulic valves in series. The features of YDL-L15 pilot hydraulic control valves are compact construction, high working pressure, better working performance, reliable working, remote controlling and etc. Besides that, it realizes to control many working functions by remote control. The valves are widely used on mechanical machines, sanitation machines, mining machines and other machines' hydraulic systems.

- ◆ 内置单向阀：阀体内置单向阀，防止油液倒流  
Inner check valve: The check valve inside the valve body is to insure the hydraulic oil not to be returned.
- ◆ 内置安全阀：阀体内置溢流阀，可调节控制系统压力  
Inner relief valve: The relief valve inside the valve body is able to adjust the hydraulic system working pressure.
- ◆ 油路形式：可实现并联、串联或串并联复合油路，带压力输出口  
Oil way: Parallel circuit, series circuit and composite with both circuit with power beyond.
- ◆ 控制方式：气控换向，也可手动换向  
Control Way: pneumatic control, manual control
- ◆ 阀体结构：分片结构，1-10联任意组合  
Valve construction: sectional construction, 1-10 levers are available to assembled as you requests.
- ◆ 阀杆机能：O、A、Y等  
Spool Function: O,A,Y etc.
- ◆ 附加阀：换向阀的两端，根据需要可增加过载阀或者补油阀  
Options of valves: The overload valves and make-up valve can be fitted on the two ends of the valve body.

### 型号说明/MODEL CODE

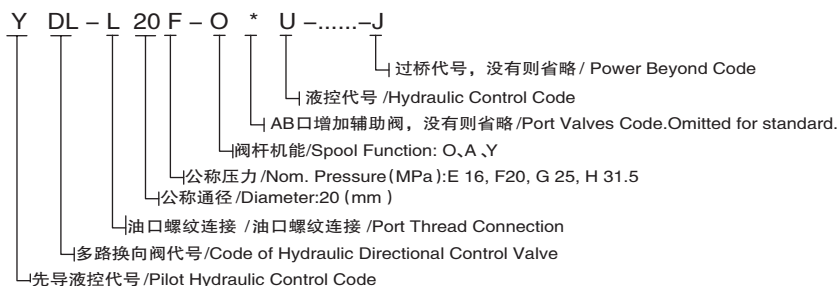

### 技术参数/PARAMETER

公称压力 (MPa) Nom. Pressure	最大压力 (MPa) Max. Pressure	公称流量 (L/min) Nom. Flow rate	中位背压 (MPa) Back Pressure	工作油液 hydraulic oil		
				温度范围 (°C) Tem.rang	粘度范围 (mm <sup>2</sup> /S) Visc.rang	过滤精度 (μm) filtrating accuracy
20	31	100	≤1	-20 ~ +80	10 ~ 400	≤10

# YDL-L20液控片式多路阀

## YDL-L20 series Pilot Hydraulic Directional Control Valves

### YDL-L20 外形安装连接尺寸/MODEL YDL-L20 DIMENSIONAL DATA

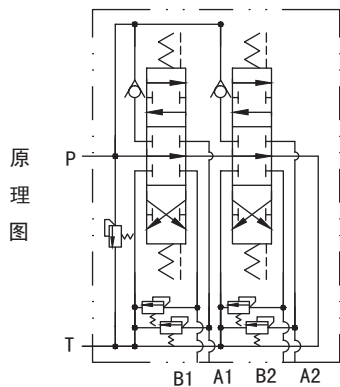
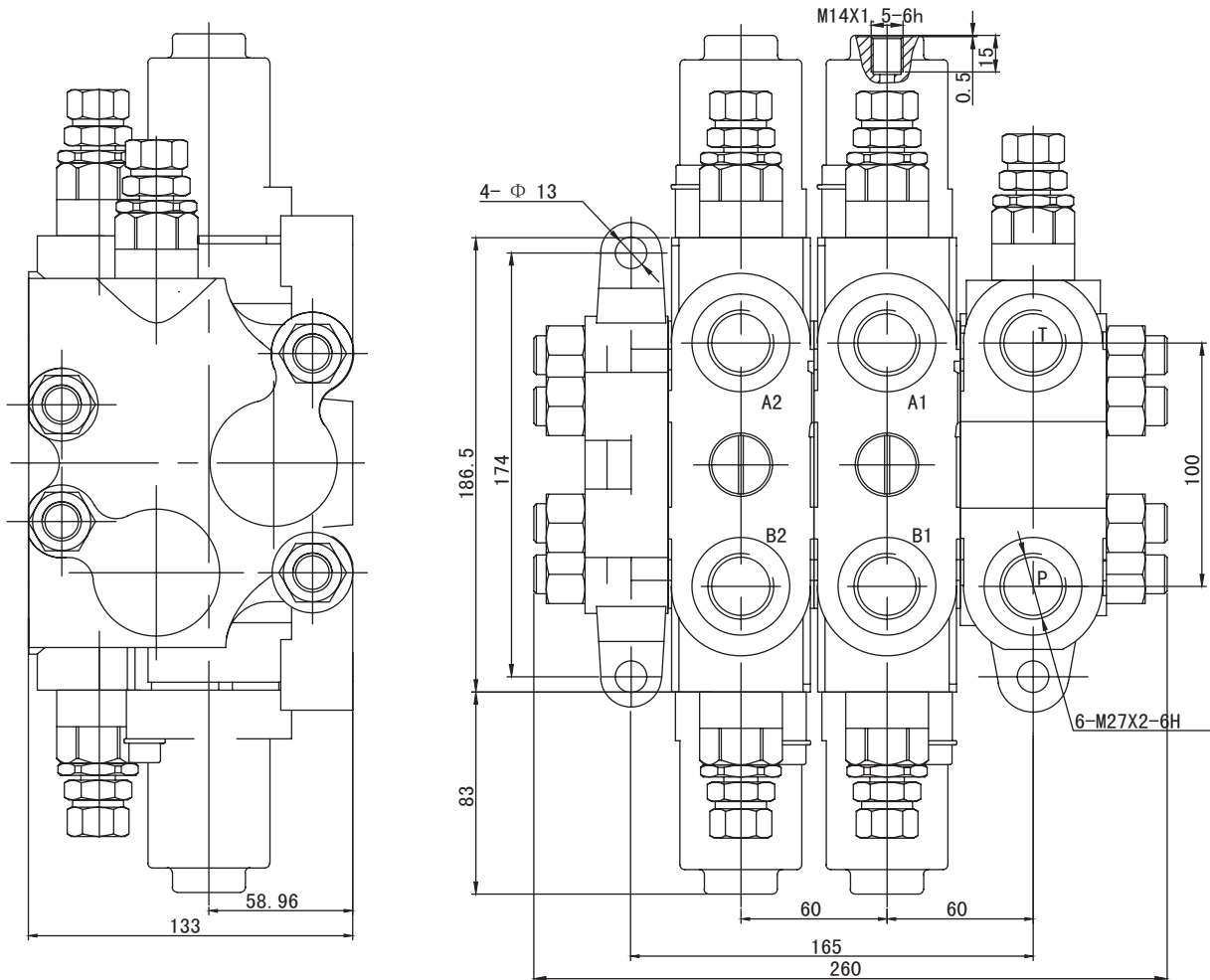

原理图

技术要求:

1. 额定通径: 20mm,
2. 额定压力: 20MPa,
3. 公称流量: 100L/min.

b71

YDL-L20液控片式多路阀SDCV

# DL-8系列分片式多路阀

## DL-8 Series Sectional Directional Control Valves

### 用途与特征/APPLICATIONS&FEATURES

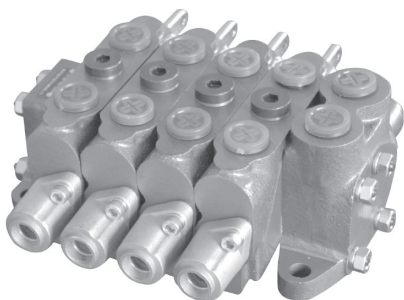

DL-8型多路换向阀是片式结构的多路阀，该阀参照多田野汽车起重机下车阀改进设计而成。它主要用于控制汽车起重机支腿的伸缩，设计中除保证原有性能外，还注重考虑了加大通往上车的油路通道，使中位压力损失大为下降，减小了系统的发热。通过各种实验和用户证明，DL-8型多路阀完全能替代多田野汽车起重机下车阀，实现了进口元件的国产化。DL-8型多路阀还可以应用于其他工程机械的液压系统中。

DL-8型多路阀是片式组装结构，是由进油体，工作阀体以及回油体组装而成，阀杆机能O、A、P、Y等机能，可根据客户需求，工作阀体1-9路任意组合。其安全阀结构紧凑，启闭性能好，噪声小。DL-8型多路阀为手动操纵，具有操纵轻便、换向灵活、定位可靠等特点。安全阀结构紧凑，启闭性能好，噪声小。DL-8型多路阀为手动操纵，具有操纵轻便、换向灵活、定位可靠等特点。

Model DL-8 sectional directional control valve is designed according to the directional control valves of the TADANO crane's hydraulic legs. It is mainly used for operating the crane's hydraulic leg extension. Model DL-8 can replace the imported control valves on cranes. Meanwhile, this model can be used on other construction machinery hydraulic systems.

Model DL-8 is assembled by inlet slice, outlet slice and working slices. The O,P,Y,A spool functions are available. And the levers from 1-10 are for options. The features of DL-8 are compact construction, lower noises. And The manual control is easy to operate and change.

### 性能参数/SPECIFICATIONS

公称通径 Nom. Dia (mm)	公称压力 Nom pressure (Mpa)	公称流量 Nom. flow (L/min)	安全阀调压范围 Pressure range of safety valve	液控单向阀开锁压力 Pilot operated check valve releasing pressure (mL/min)
8	20	30	6~25	≤2.8
工作油液 Hydraulic Oil		温度范围 Tem.range (°C)	粘度范围 Visc.range (mm <sup>2</sup> /s)	过滤精度 Filtrating accuracy (μm)
		-20~+80	10~400	≤10

注：油液最高污染等级：按GB/T14039之19/16。

Note: maximum permissible degree of contamination of the oil is according to GB/T14039-19/16.

# DL-8系列分片式多路阀

## DL-8 Series Sectional Directional Control Valves

### 型号说明/MODEL CODE

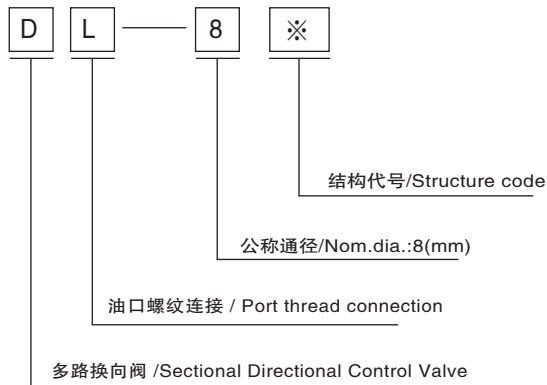

注：订货有特殊要求者，请与销售顾问联系。

Note: Special features not listed can often be made to your specifications. Please consult your sales representative.

### DL-8J 外形安装连接尺寸/MODEL DL-8J DIMENSIONAL DATA

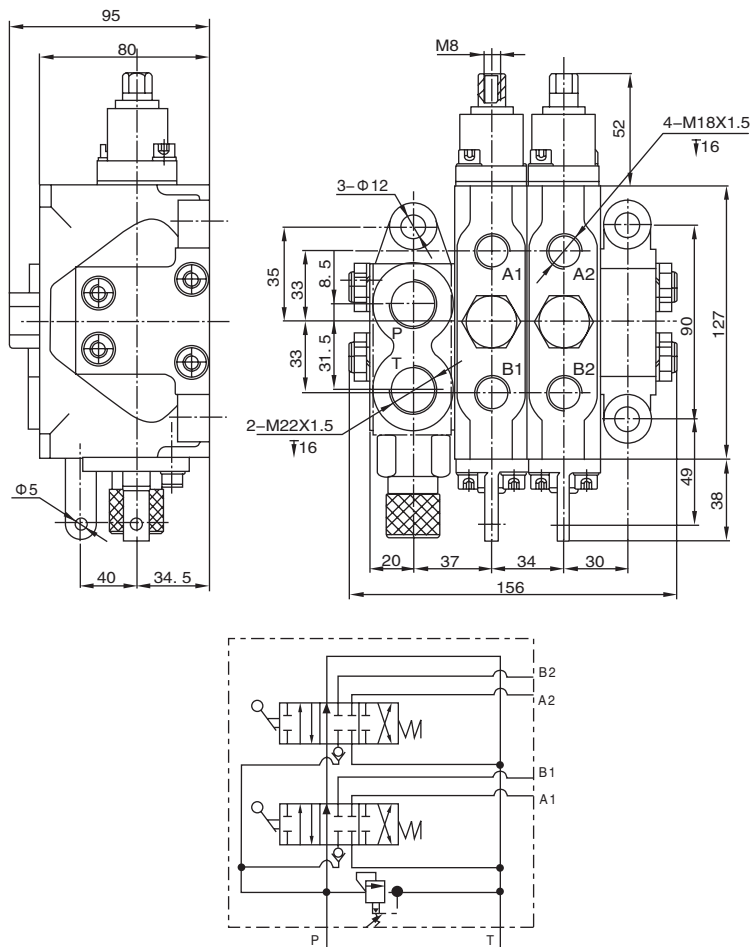

# DL-8系列分片式多路阀

## DL-8 Series Sectional Directional Control Valves

### DL-8M 外形安装连接尺寸/MODEL DL-8M DIMENSIONAL DATA

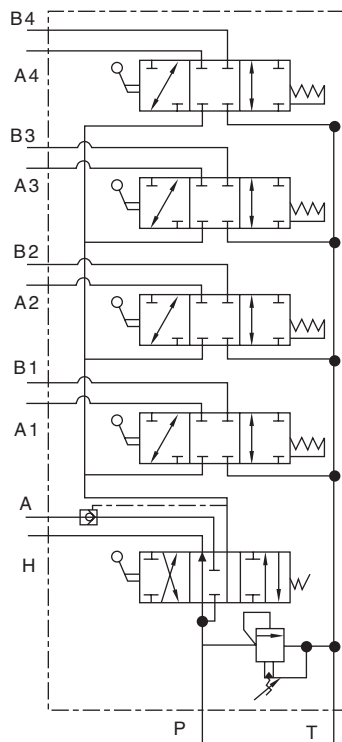
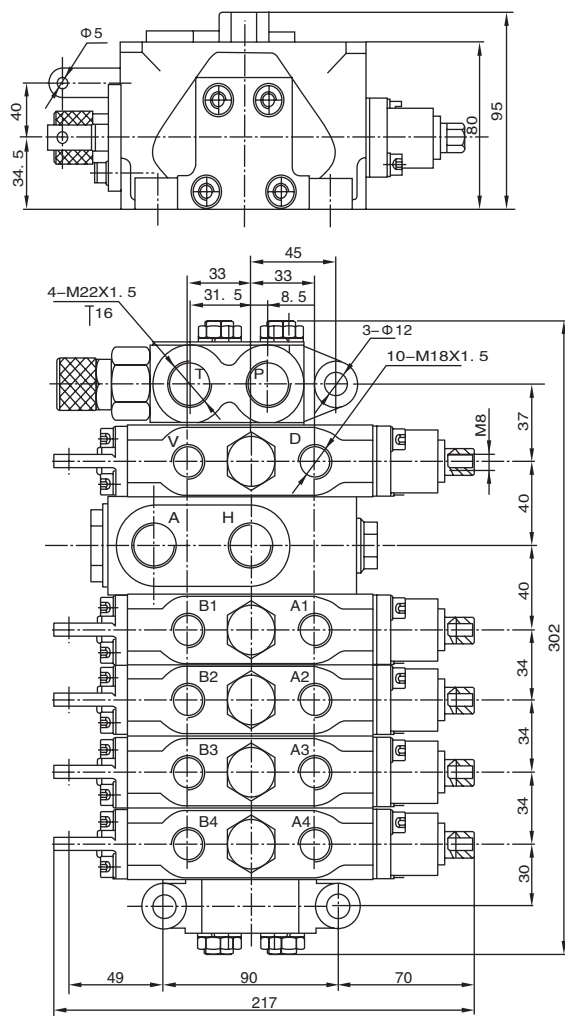

### 备注

1. 此阀在出厂时不配操纵手柄, 但本公司可以根据客户的需要定做手柄, 如有需要请与公司联系。
2. 客户应尽可能的使用在进油盖和回油盖上的安装孔进行固定。各种阀片进行多重组合能产生不同的效果, 客户可选用已提供的型号。若客户有其他的要求可以与销售顾问进行联系。

#### Note:

1. No handle levers will be provided with the valves. But we can make the handle levers to your requests. If required, please contact with your sales representative.
2. The customers should fix the valves by the assembling holes on the inlet and outlet slices. Different effectual maybe achieved by different working slices. Speical features not listed can often be made to your specifications, please consult your sales representative.

b74

DL-8系列分片式多路阀SDCV

# DF-50系列分片式多路阀

## DF-50 Series Sectional Directional Control Valves

### 用途与特征/APPLICATIONS&FEATURES

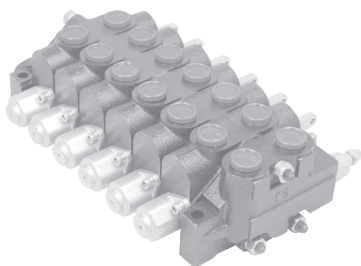

DF-50型多路阀是并联式手动换向阀，具有高度集成的结构，压力损失小，工作可靠，安装维修方便等特点，可实现多个执行机构的集中控制，可按不同的使用要求组合功能阀片。该系列多路阀每连都带单向阀。根据用户需要，可在任一工作腔和回油腔之间安装过载阀或补油阀，单双作用调节手柄可以根据机型的不同进行互相转换。DF50系列多路阀广泛应用于各类行走机械中。

Model DF-50 features:

- ◆ Inner check valve: The check valve inside the valve body is to insure the hydraulic oil not to be returned.
- ◆ Inner relief valve: The relief valve inside the valve body is able to adjust the hydraulic system working pressure.
- ◆ Oil way: Parallel circuit, power beyond for option.
- ◆ Control Way: manual control
- ◆ Valve construction: sectional construction, 1-10 levers are available to assembled as you requests.
- ◆ Spool Function: O,A,Y ,P, Q etc.
- ◆ Options of valves: The overload valves and make-up valve can be fitted on the two ends of the valve body.

### 性能参数/SPECIFICATIONS

公称压力 Nom pressure (Mpa)	最大压力 Max. pressure (Mpa)	公称流量 Nom. flow ( L/min )	允许背压 Allowable Back pressure (Mpa)	工作油液 Hydraulic Oil		
				温度范围 Tem.range (°C)	粘度范围 Visc.range (mm2/s)	过滤精度 Filtrating accuracy ( μ m )
16	25	50	≤1	-20~+80	10~400	≤10

注：油液最高污染等级：按GB/T14039之19/16。

Note: maximum permissible degree of contamination of the oil is according to GB/T14039-19/16.

### 型号说明/MODEL CODE

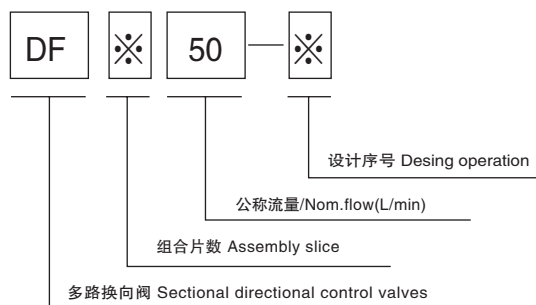

注：订货有特殊要求者，请与销售顾问联系。

Note: Special features not listed can often be made to your specifications. Please consulte your sales representative.



# DF-50系列分片式多路阀

## DF-50 Series Sectional Directional Control Valves

### DF-650 外形安装连接尺寸/MODEL DF-650 DIMENSIONAL DATA

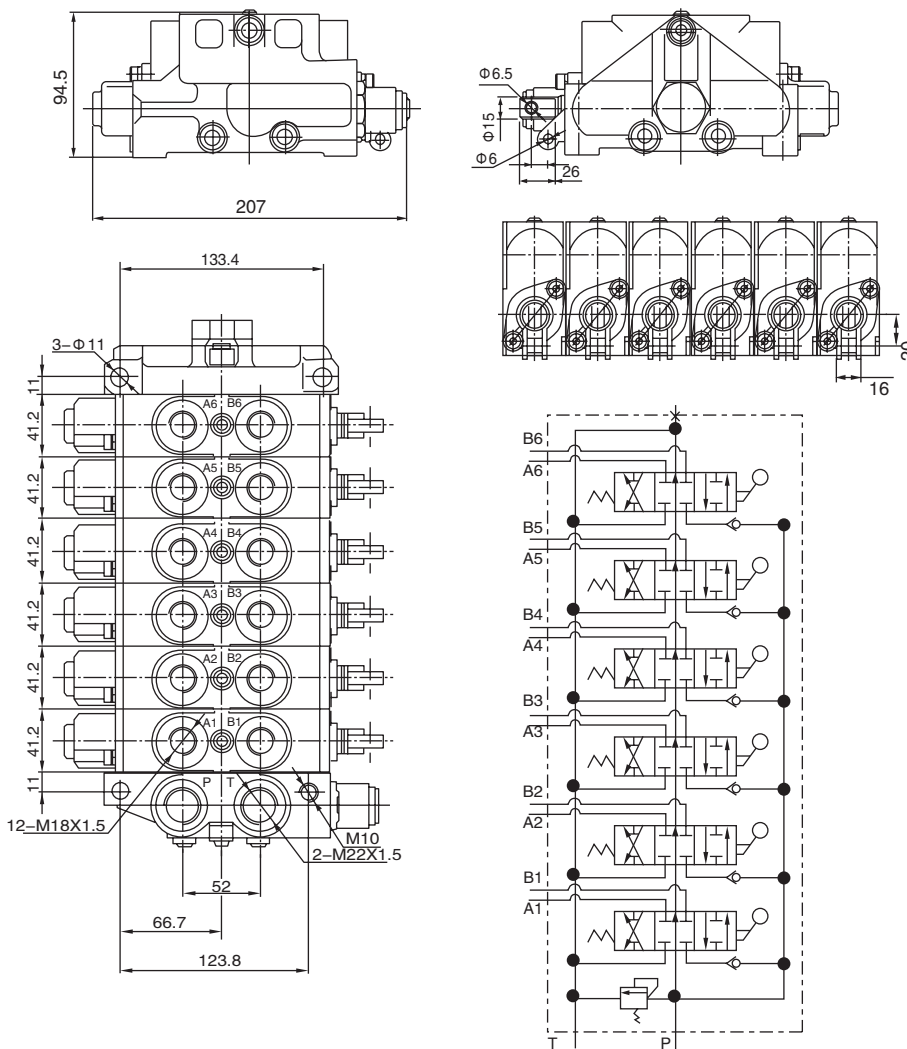

#### 备注

- 1、DF50型多路阀功能阀片宽度均为41.2mm，则阀体长度等随着阀片的增加相应的加长41.2mm。
- 2、此阀在出厂时不配操纵手柄，但本公司可以根据客户的需要定做手柄，如有需要请与公司联系。
- 3、客户应尽可能的使用在进油盖和回油盖上的安装孔进行固定。
- 4、各种阀片进行多重组合能产生不同的效果，客户可选用已提供的型号。若客户有其他的要求可以与公司技术部进行联系。

1. The working slice of DF50 width is 41.2mm, so the total width of the valve should be added 41.2mm with the increasing numbers of slices.
2. The handle lever is not standard. If you need levers, please inform us, we will make it to your specifications.
3. The valves should be fixed with the assembling holes on the valve body.
4. Special features not listed can often be made to your specifications. Please consult your sales representative.

# CDB系列分片式多路阀

## CDB Series Sectional Directional Control Valves

### 用途与特征/APPLICATIONS&FEATURES

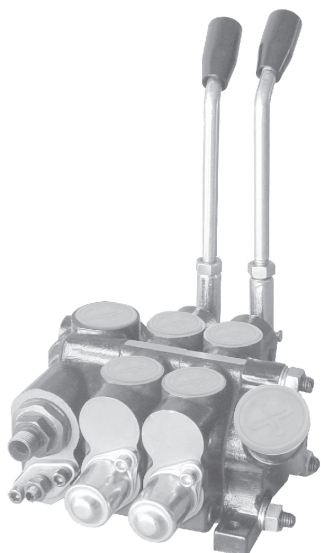

CDB系列多路换向阀是我公司根据国内1-10T叉车、小型装载机、平地机液压系统，并引进、消化吸收国外先进技术而进行优化设计的新产品，CDB系列多路换向阀不但适用于叉车、小型装载机、平地机液压系统，还可以应用于其他起重运输机械、矿山机械液压系统中，使主机实现进口元件国产化的理想产品。

#### 结构特点：

采用片式结构，1-10连内可以任意组合。

油路形式为并联、串并联。

进油片内设有稳流装置，保证转向系统正常工作。

换向片内可带过载阀、二次压力阀、补油阀等附加阀供用户选择。

滑阀机能可有O、A、R、Y、O<sub>x</sub>等，供用户任意组合。

CDB15型多路换向阀适用于单泵分流双回路系统。

CDB20型多路换向阀适用于双泵分流双回路系统。

CDB系列多路换向阀功能全、性能佳、结构紧凑、安全可靠、维修方便。

CDB series hydraulic valve is a new product according to domestic 1-10T forklift, small size loaders and flat land hydraulic system by our company, and import and digest abroad advanced technologies. CDB series valves are not only used in hydraulic system forklift mini loaders and planers, but also hydraulic systems of other lifting transportation machinery and mining machinery. The valve is an ideal substitute for imported parts.

#### Structure features:

The valve can be combined from one to ten .

The oil circuit mode is parallel connection or series connection.

There is an equipment with flow stabilizing unit to ensure the system function normally.

There are additional valves such as overload valve, secondary pressure valve, and make up oil valve are available for users.

The spool function include O, A, R, Y, O for user selection and combination.

CDB15 valve is applicable to single pump split-flow double circuit system.

CDB20 series valve is applicable to double pump split-flow circuit system.

The CDB series valve has a global function with high quality, compact structure. They are both reliable and easily maintenance.

b78

CDB系列分片式多路阀SDCV

# CDB系列分片式多路阀

## CDB Series Sectional Directional Control Valves

### 性能参数/SPECIFICATIONS

公称通径 Nom dia.(mm)	15		20		
额定压力 Rated flow(L/min)	80		160		
公称压力 Nom pressure.(Mpa)	E	F	E	F	G
	16	20	16	20	25
主安全阀调压范围 Pressure range of main relief valve(Mpa)	8—20		8—25		
转向安全阀调压范围 Pressure range of steering relief valve(Mpa)	3—10		3—20		
转向输出流量范围 Steering flow output range(L/min)	11—16		22—32		
过载阀调压范围 (含二次压力阀) Overload valve pressure range(Including secondary pressure valve)(Mpa)	6.3—22		8—28		
许用背压 Allowable back pressure at port(Mpa)	2				
R 阀控制压差 R spool control control pressure difference(Mpa)	≤2				
工作油液 Hydraulic oil	温度范围 Temp.range (°C)	粘度范围 Visc.range(mm <sup>2</sup> /s)	过滤精度 Filtrating accuracy(μ m)		
	-20—+80	10—400	≤10		

### 首块代号/First block code

表1/Table 1

通径	代号	说明	视图
15	省略 Omitted	PF 口为 M16X1.5 (基型) PF port with M16X1.5	
	H	PF 口为 M14X1.5 PF port with M14X1.5	
	H1	PF 口为 M20X1.5 PF port with M20X1.5	
	H2	PF 口为 M22X1.5 PF port with M22X1.5	
20	省略 Omitted	进油体带分流装置	
	H	进油体不带分流装置	

注: 如有特殊要求, 请与销售顾问联系。

Notes: Special features not listed on can often be made to your specifications. Please consult your sales representation.

# CDB系列分片式多路阀

## CDB Series Sectional Directional Control Valves

A、B口带的辅助阀/AUXILIARY VALVE ON PORTS A&B 表2/Table 2

代号 Code		液压图形符号 Hydraulic graphic symbols	附带的辅助阀 Auxiliary valve	
过载阀压力与进油口 安全阀压力相同 The overload valve has the same pressure as the relief valve at the inlet port	过载阀压力与进油口 安全阀压力不相同 The overload valve has different pressure from the relief valve at the inlet port		A□	B□
无/No	无/No		无/No	无/No
1	1		无/No	过载阀 Overload valve
2	2		无/No	补油阀 Make up valve
3	3		过载阀 Overload valve	无/No
4	4		过载阀 Overload valve	过载阀 Overload valve
5	5		过载阀 Overload valve	补油阀 Make up valve
6	6		补油阀 Make up valve	无/No
7	7		补油阀 Make up valve	过载阀 Overload valve
8	8		补油阀 Make up valve	补油阀 Make up valve

b80

CDB系列分片式多路阀SDCV

# CDB-F15系列分片式多路阀

## CDB-F15 Series Sectional Directional Control Valves

### 型号说明/MODEL CODE

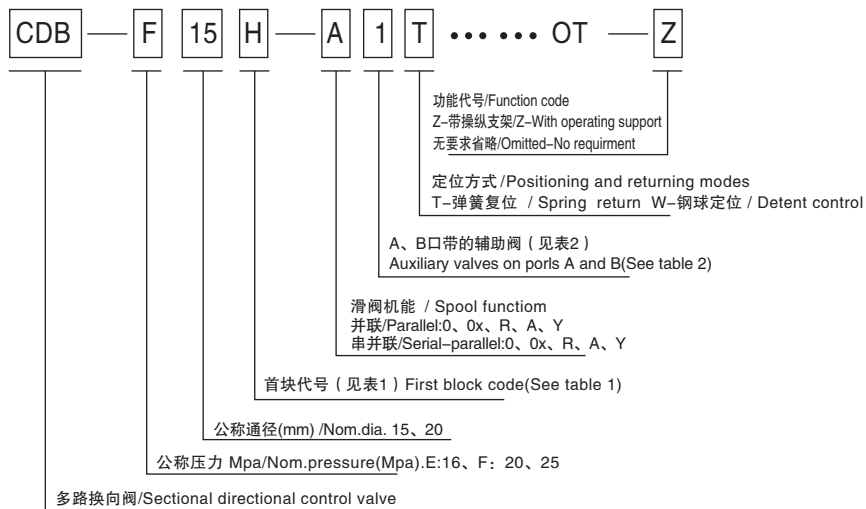

注: 订货有特殊要求者, 请与销售顾问联系。

Note: Special features not listed can often be made to your specifications. Please consulte your sales representative.

### CDB-F15 外形安装连接尺寸/MODEL CDB-F15 DIMENSIONAL DATA

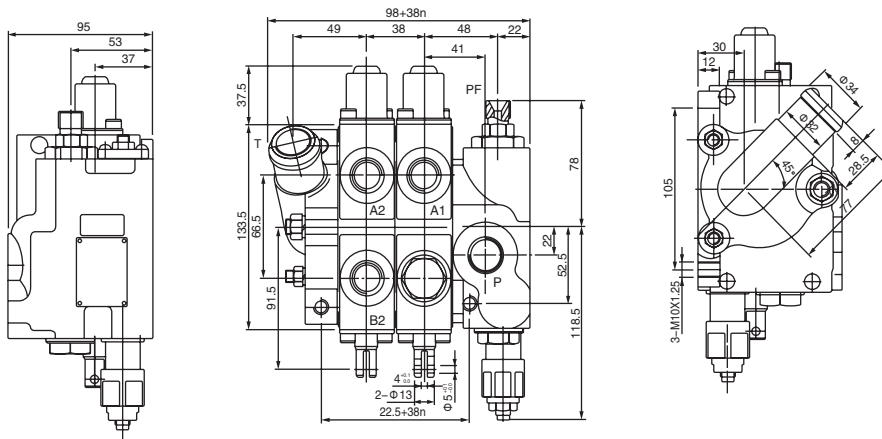

PF 口尺寸参照表1

P 口放大尺寸

A、B 口放大尺寸

CDB-F15-A5T.R3T

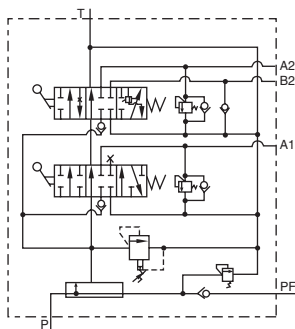

注: n表示多路换向阀连数片

Note: N is the number of direction valve pieces.

# ZCDB-F15系列分片式多路阀

## ZCDB-F15 Series Sectional Directional Control Valves

### 用途与特征/APPLICATIONS&FEATURES

ZCDB-※15系列多路换向阀是由单向阀、安全阀、进油体、回油体和多个换向阀片组合而成的组合阀，以手动换向阀为主，它具有结构紧凑、工作压力高、性能优异、工作可靠等特点。油路采用并联油路，有多种滑阀机能供系统需要，阀杆复位方式采用手动换向弹簧自动复位或钢珠定位，阀片内部设置单向阀，以防止油液倒流，进油阀片带有溢流阀，以控制整个系统压力。根据用户需要，换向阀片两端可装有过载阀以满足不同执行机构负载需要，该阀广泛用于叉车、环保车等工程机械的液压系统。

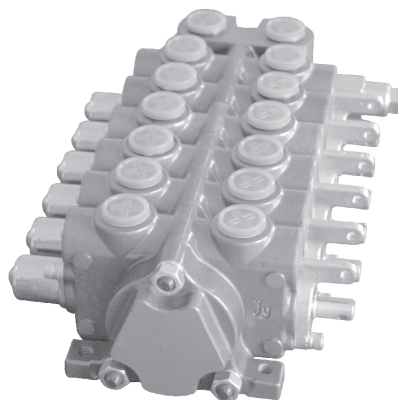

ZCDB-※15 series sectional directional hydraulic control valve is a kind of combination valve assembled with check valve, inlet slice, outlet slice and working slices. This valve has such characteristics as compact structure, high working pressure, good performance, high reliability, etc. The circuit is parallel connection. There are many spool functions for option. The positioning and returning modes of the valve include spring returning and detent control. There is a check valve inside the valve plate in case of back flow. There is a main relief valve in the inlet slice to control the whole system pressure. According to the customers' requestes, the overload valve can be assembled on A, B port. The valve is widely used in such hydraulic systems of engineering machinery as forklift, environmental trucks, etc.

### 型号说明/MODEL CODE

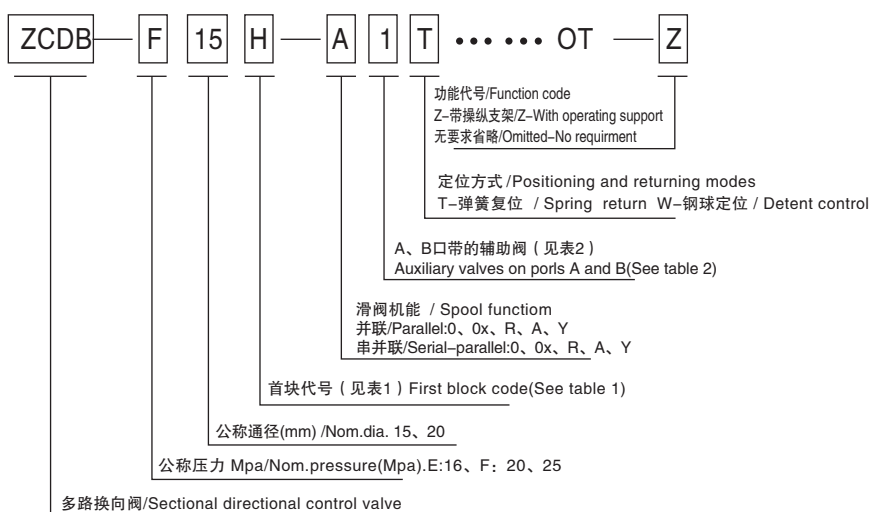

注：订货有特殊要求者，请与销售顾问联系。

Note: Special features not listed can often be made to your specifications. Please consult your sales representative.

# ZCDB-F15系列分片式多路阀

## ZCDB-F15 Series Sectional Directional Control Valves

### 型号举例/MODEL EXAMPLES

ZCDB-※15-Y4W. O5T. Q1W-J

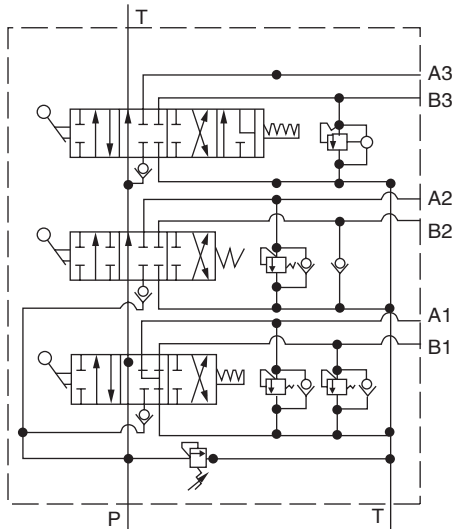

ZCDB-※15-M4T. O5T. QW

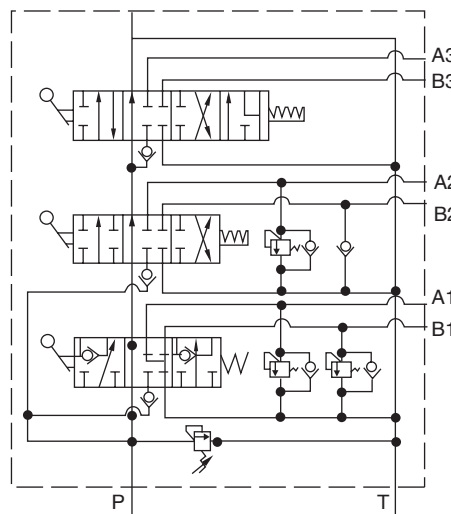

### ZCDB-F15 外形安装连接尺寸/MODEL ZCDB-F15 DIMENSIONAL DATA

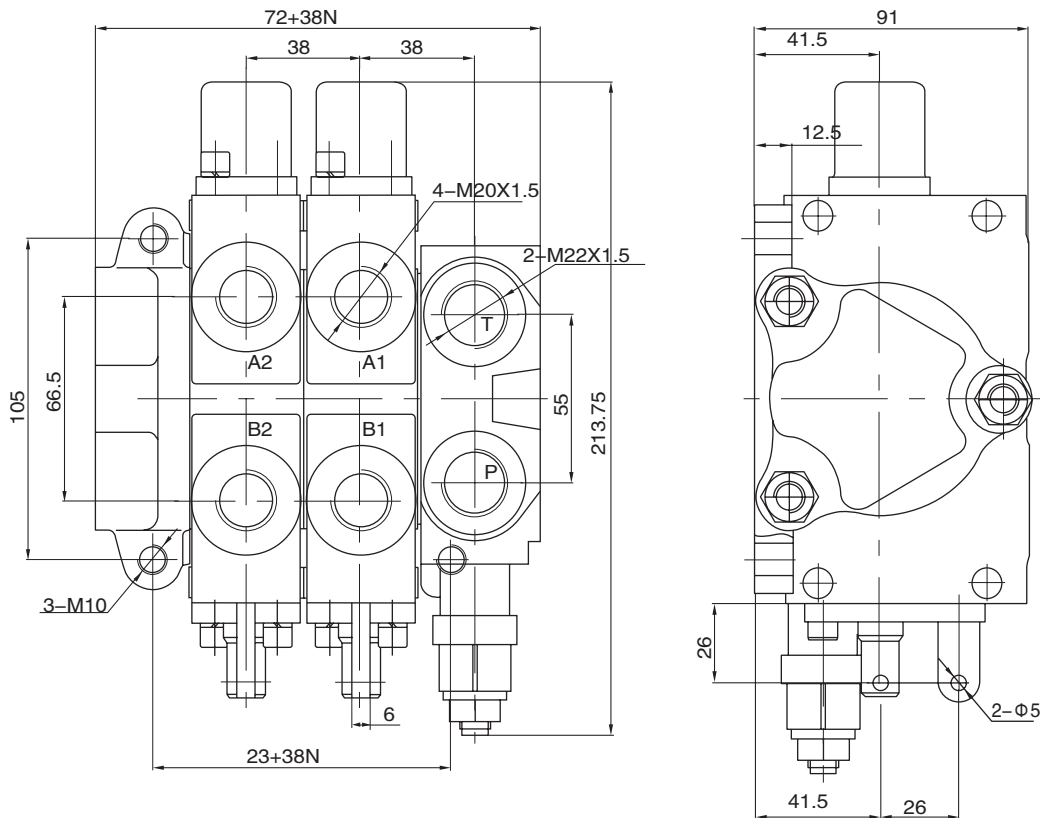

注: n表示多路换向阀连数片  
Note: N is the number of direction valve pieces.

# CDB-F20系列分片式多路阀

## CDB-F20 Series Sectional Directional Control Valves

### CDB-F20 外形安装连接尺寸/MODEL CDB-F20 DIMENSIONAL DATA

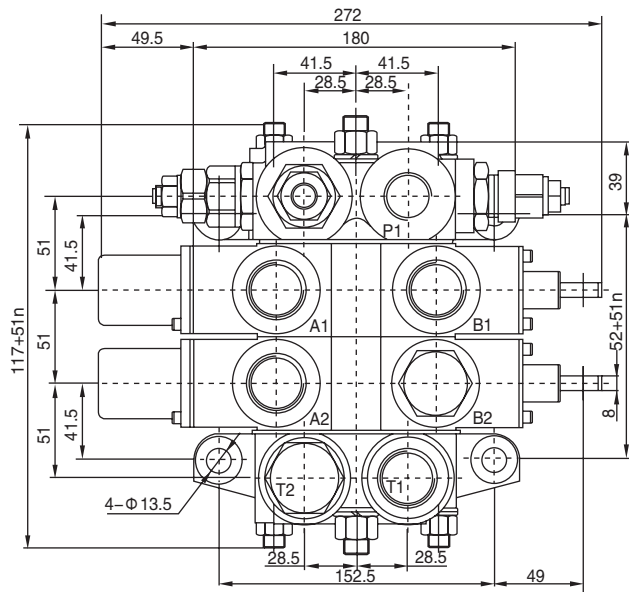

油口尺寸

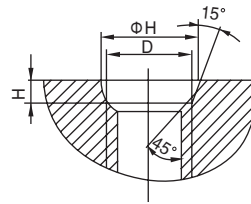

油口尺寸表

油口	D	H	$\phi U$
P1、P2	G3/3	3.5 <sup>+0.1</sup>	30.2 <sup>+0.1</sup>
A、B、T2	M33X2	3.3 <sup>+0.1</sup>	32.4 <sup>+0.1</sup>
T2	M33X2	3.5 <sup>+0.1</sup>	35.5 <sup>+0.1</sup>
C	测压口NPT1/8 Pressure measuring port		

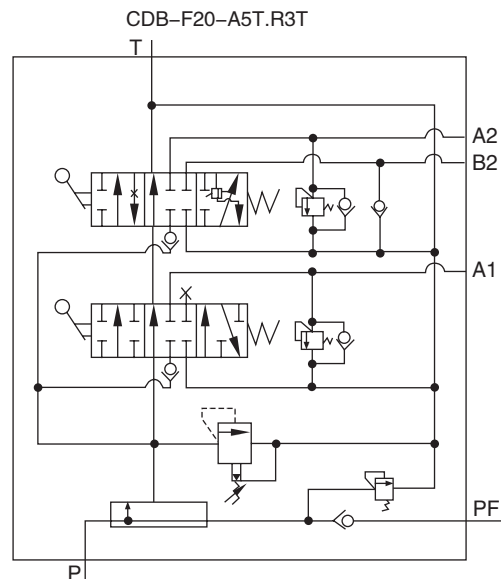
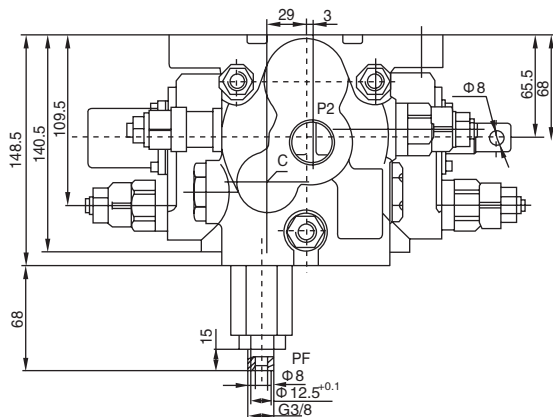

注: n表示多路换向阀连数片  
Note: N is the number of direction valve pieces.

# ZCDB-F20系列分片式多路阀

## ZCDB-F20 Series Sectional Directional Control Valves

### ZCDB-F20 外形安装连接尺寸/MODEL ZCDB-F20 DIMENSIONAL DATA

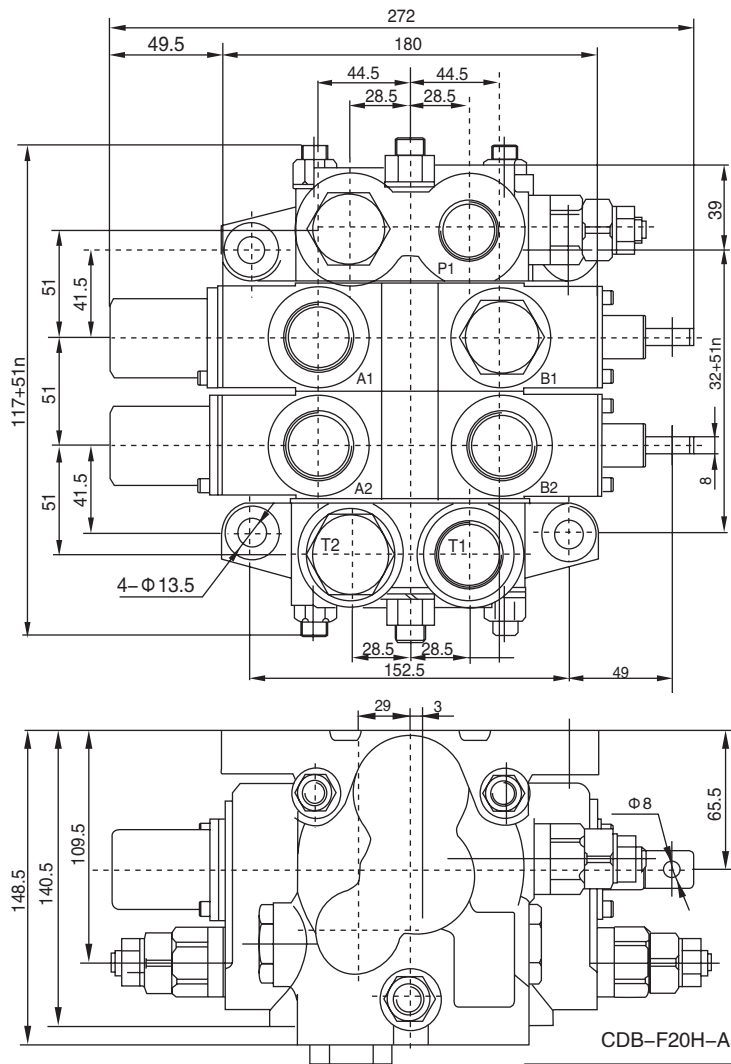

油口尺寸参照CDB※20油口尺寸表  
Oil mouth dimensions refer to CDB...

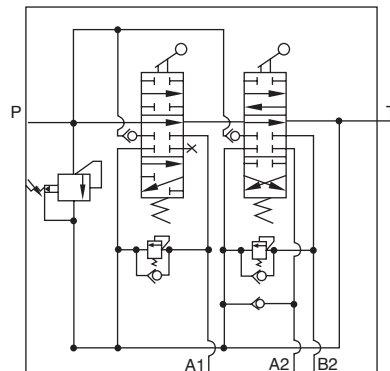

注：n表示多路换向阀连数片  
Note: N is the number of direction valve pieces.

b85

ZCDB-F20系列分片式多路阀SDCV

# LKF-60 压力补偿可变流量控制阀

## LKF-60 Pressure Compensating Flow Control Valve

### 产品描述/SPECIFICATION

LKF是全范围压力补偿可变流量控制阀。经过精心设计，它的节流口面积会随着阀杆的旋转而变化。不论CF油口EX油口的压力如何变化，控制油口的流量始终是平稳恒定的。它拥有一个可调节的弹簧安全阀使压力可以上升到设置的安全压力。安全阀的压力出厂设置是1500psi，可调节范围是750-3000psi。

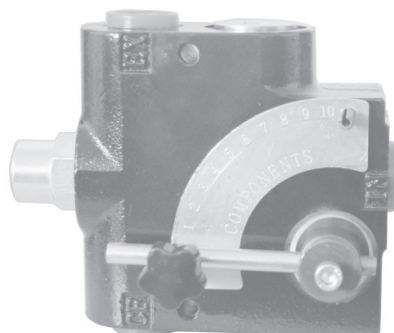

### 产品特点/FEATURES

LKF model is a full range pressure compensating variable flow control. It is designed so that the orifice area varies as the lever is rotated. The outlet flow is smooth and constant regardless of the pressure on the control flow or excess flow ports. An adjustable ball spring relief valve allows for pressure compensated how up to the pressure setting on the relief valve. Relief valves are preset at 1500psi and filed adjustable from 750 to 3000psi.

### 技术参数/PARAMETERS

型号 Model	油口尺寸 Oil Port	流量 Flow(gpm)	公称压力 (bar) Standard Pressure
LKF-40-3/8NPT	3/8" -NPT	0-30L/min (0-8gpm)	210
LKF-60-1/2NPT	1/2" -NPT	0-60L/min (0-16gpm)	
LKF-114-3/4NPT	3/4" -NPT	0-114L/min (0-30gpm)	

### LKF60流量曲线/LKF60 Curve of Flow

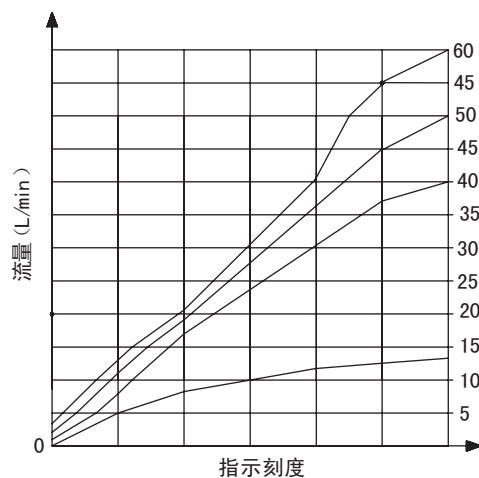

### LKF60 压力损失表/LKF60 Curve of Pressure Drop

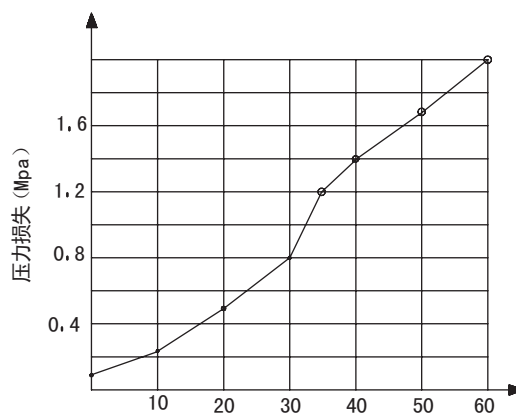

c1

LKF-60 压力补偿可变流量控制阀 FCV

# LKF-60 压力补偿可变流量控制阀

## LKF-60 Pressure Compensating Flow Control Valve

### LKF-60外形安装连接尺寸/MODEL LKF-60 DIMENSIONAL DATA

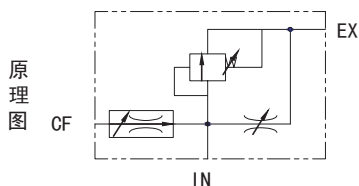
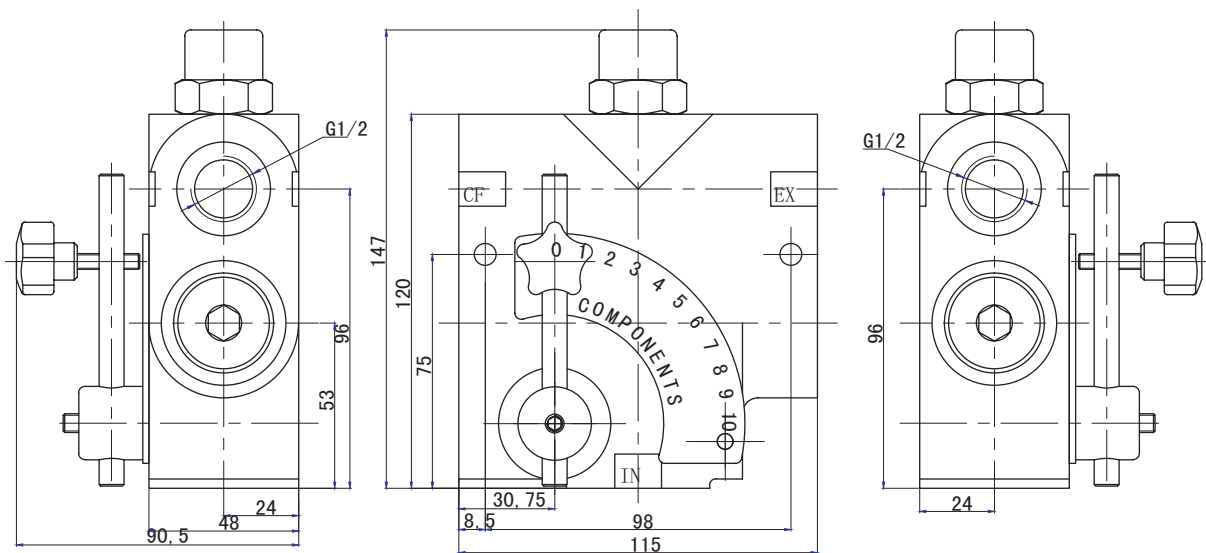

#### 技术参数:

1. 公称通径 15mm
2. 公称压力 21MPa
3. 公称流量 0-60L/min

注: 订货有特殊要求者, 请与销售顾问联系。

Note: Special features not listed can often be made to your specifications. Please consult your sales representative.

# SVV06电磁切换阀

## SVV06 Solenoid Diverter Valve

### 用途与特征/APPLICATIONS&FEATURES

- 1.SVV06是分片式6通电磁切换阀，也可以做成8通和10通的油路。
- 2.SVV06油口可以安装带法兰式叠加块，可安装防震动阀。
- 3.有多种不同电压的电磁阀可供选择
- 4.SVV06电磁切换阀是基础的多路阀和2个液压执行元件之间的链接点。
- 5.切换阀是用于液压系统中需要在原有多路阀的基础上按顺序增加一个执行元件时，可以通过增加切换阀来实现同一个多路阀，可按顺序控制2个不同的执行元件。
- 6.叠加式切换阀原理可以允许单连阀通过串联的方式，连接5个切换阀，从而控制6个执行元件。
- 7.L口必须一直接回油箱。



#### Sectional SVV Series

- ◆ 6-way with alternating spool; it's sectional type to obtain 8-way or 10 way circuit.
- ◆ It's possible to flange mounting a block with cross return anti-shock valves.
- ◆ Coils with several feeding voltage are available.
- ◆ They are used as link between two consumers and the basic directional valve, when we want to control both consumers alternately by means of one basic directional control valve.
- ◆ Diverters are used to add an extra facility to the directional control valve when it is needed for a sequence of operations  
such as a safety operation or to control a selected hydraulic cylinder.
- ◆ The stackable circuit selector valves allow one single drive for 6 users with 5 diverters connected in series.
- ◆ Please note the drain line must be connected back to tank at all times.

### 型号说明/MODEL CODE

SVV06 - G3/8 - L - DC12V

控制电压/Voltage:DC12V,DC24V

卸油孔标记L口，没有可省略

L:Drain Port, No drain port is omitted.

螺纹规格 Port Size: G3/8,G1/2,SAE8

切换阀代号/Solenoid Diverter Valve

c3

SVV06电磁切换阀

# SVV06电磁切换阀

## SVV06 Solenoid Diverter Valve

### 技术参数/PARAMETERS

最大压力 Max Pressure/bar	带L口 With L	315	工作电压 Supply Voltage/V	12,24VDC, 220VAC
最大压力 Max Pressure/bar	不带L口 Without L	210	功率 Power/W	30
流量 Flow Rate/LPM	最大 MAX	50	切换频率 Switching Frequency/1/h	15000
油温 Oil Temperature	℃	-40~+70	室温 Ambient Temperature	To 50℃
油液粘度 Viscosity	Mm/s	15~380	线圈温度 Coil Temperature	To 180℃
过滤精度 Filtration	NAS1638	9	线圈工作制式 Duty Cycle	100%ED

注：订货有特殊要求者，请与销售顾问联系。

Note: Special features not listed can often be made to your specifications. Please consult your sales representative.

### SVV06外形安装连接尺寸/MODELR SVV06 DIMENSIONAL DATA

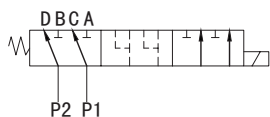
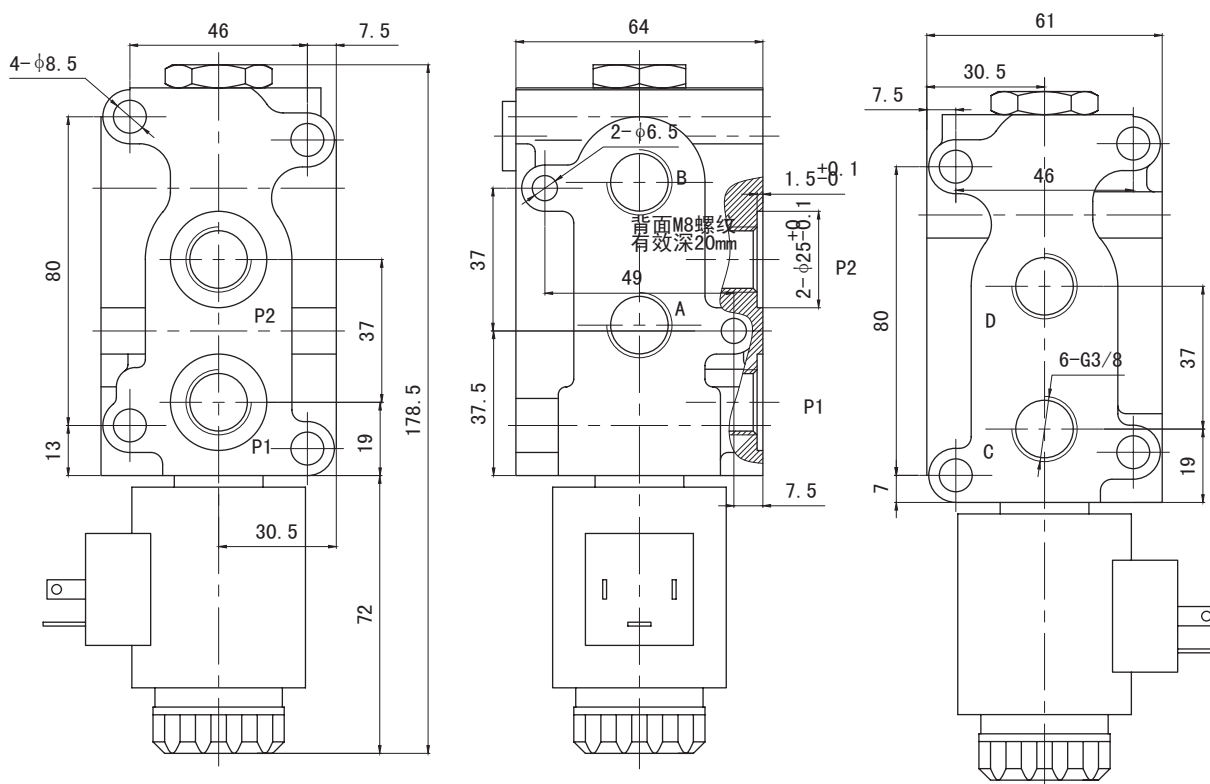

- 主要技术参数:
1. 最大流量50L/min,
  2. 最大压力31.5MPa,
  3. 控制电压DC12V/DC24V

# DVS90电磁切换阀

## DVS90 Solenoid Diverter Valve

### 用途与特征/APPLICATIONS&FEATURES

- 1.DVS90是分片式6通电磁切换阀，也可以做成8通和10通的油路。
- 2.DVS90油口可以安装带法兰式叠加块，可安装防震动阀。
- 3.有多种不同电压的电磁阀可供选择
- 4.DVS90电磁切换阀是基础的多路阀和2个液压执行元件之间的链接点。
- 5.切换阀是用于液压系统中需要在原有多路阀的基础上按顺序增加一个执行元件时，可以通过增加切换阀来实现同一个多路阀，可按顺序控制2个不同的执行元件。
- 6.叠加式切换阀原理可以允许单连阀通过串联的方式，连接5个切换阀，从而控制6个执行元件。
- 7.L口必须一直接回油箱。



#### DVS90 Solenoid Diverter Valve

- ◆ 6-way with alternating spool; it's sectional type to obtain 8-way or 10 way circuit.
- ◆ It's possible to flange mounting a block with cross return anti-shock valves.
- ◆ Coils with several feeding voltage are available.
- ◆ They are used as link between two consumers and the basic directional valve, when we want to control both consumers alternately by means of one basic directional control valve.
- ◆ Diverters are used to add an extra facility to the directional control valve when it is needed for a sequence of operations such as a safety operation or to control a selected hydraulic cylinder.
- ◆ The stackable circuit selector valves allow one single drive for 6 users with 5 diverters connected in series.
- ◆ Please note the drain line must be connected back to tank at all times.

### 型号说明/MODEL CODE

DVS90 - G1/2 - L - DC12V

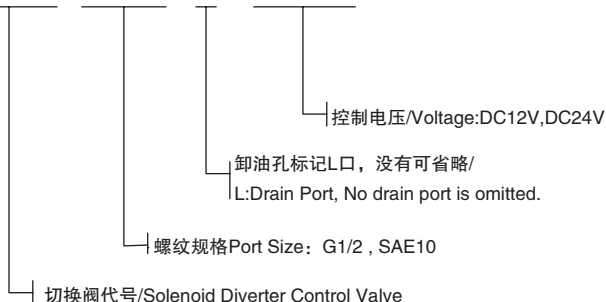

# DVS90电磁切换阀

## DVS90 Solenoid Diverter Valve

### 技术参数/PARAMETERS

最大压力 Max Pressure/bar	带L口 With L	315	工作电压 Supply Voltage/V	12,24VDC 220VAC
最大压力 Max Pressure/bar	不带L口 Without L	210	功率 Power/W	60W,37W
流量 Flow Rate/LPM	最大 MAX	50	切换频率 Switching Frequency/1/h	15000
油温 Oil Temperature	℃	-40~+70	室温 Ambient Temperature	To 50℃
油液粘度 Viscosity	Mm/s	15~380	线圈温度 Coil Temperature	To 180℃
过滤精度 Filtration	NAS1638	9	线圈工作制式 Duty Cycle	100%ED

注：订货有特殊要求者，请与销售顾问联系。

Note: Special features not listed can often be made to your specifications. Please consult your sales representative.

### DVS90外形安装连接尺寸/MODELR DVS90 DIMENSIONAL DATA

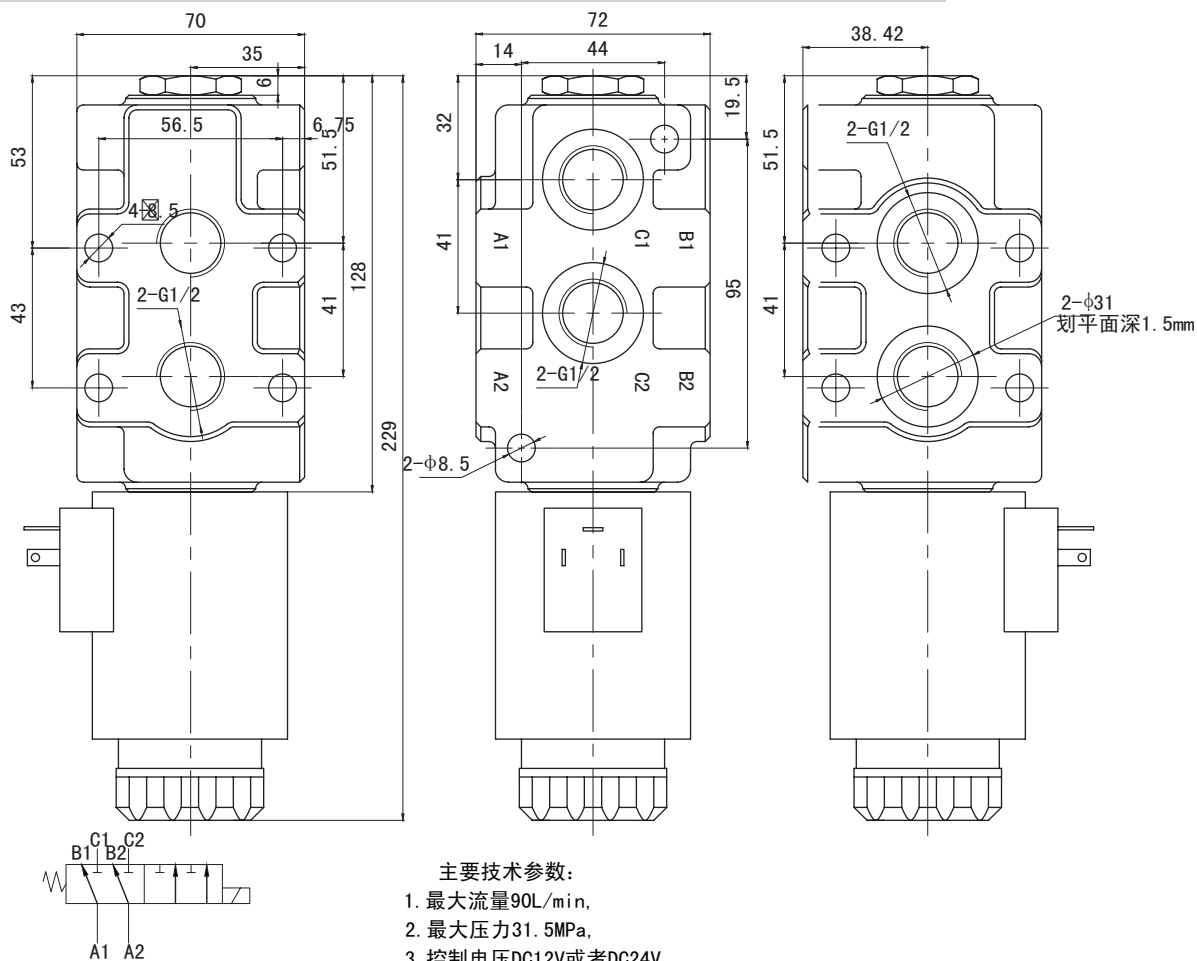

# SVV09电磁切换阀

## SVV09 Solenoid Diverter Valve

### 用途与特征/APPLICATIONS&FEATURES

- 1.SVV09是分片式6通电磁切换阀，也可以做成8通和10通的油路。
- 2.SVV09油口可以安装带法兰式叠加块，可安装防震动阀。
- 3.有多种不同电压的电磁阀可供选择
- 4.SVV09电磁切换阀是基础的多路阀和2个液压执行元件之间的链接点。
- 5.切换阀是用于液压系统中需要在原有多路阀的基础上按顺序增加一个执行元件时，可以通过增加切换阀来实现同一个多路阀，可按顺序控制2个不同的执行元件。
- 6.叠加式切换阀原理可以允许单连阀通过串联的方式，连接5个切换阀，从而控制6个执行元件。
- 7.L口必须一直接回油箱。



#### SVV09 Solenoid Diverter Valve

- ◆ 6-way with alternating spool; it's sectional type to obtain 8-way or 10 way circuit.
- ◆ It's possible to flange mounting a block with cross return anti-shock valves.
- ◆ Coils with several feeding voltage are available.
- ◆ They are used as link between two consumers and the basic directional valve, when we want to control both consumers alternately by means of one basic directional control valve.
- ◆ Diverters are used to add an extra facility to the directional control valve when it is needed for a sequence of operations  
such as a safety operation or to control a selected hydraulic cylinder.
- ◆ The stackable circuit selector valves allow one single drive for 6 users with 5 diverters connected in series.
- ◆ Please note the drain line must be connected back to tank at all times.

### 型号说明/MODEL CODE

SVV09 - G1/2 - L - DC12V

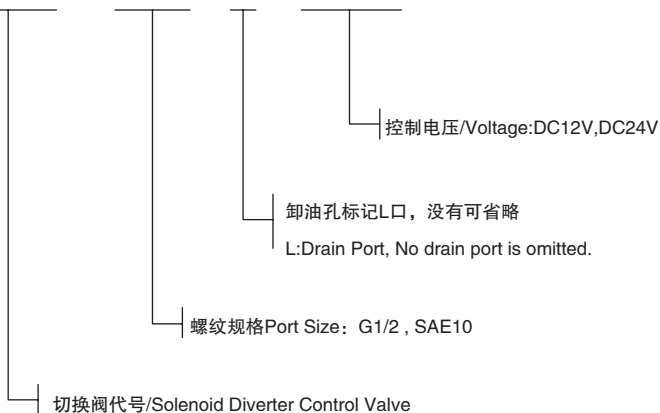



# RV系列转阀

## RV Series Rotary Spool Valves

### 用途与特征/APPLICATIONS&FEATURES

RV系列液压转阀是由阀体、内部阀芯和手柄杆组成。转阀有3通，4通，6通，8通，可以根据客户需要定制，同时有中位开启和关闭两种不同的阀芯机能，流量从60LPM到200LPM。RV系列液压转阀可以实现快速准确的切换油缸和马达之间的油路。客户可以选择3通油路，可以从A路切换到B路或者在中位回油箱。



- ◆ The directional control valves of the rotary spool type consists basically of a rotor
- ◆ which is rotated with respect to the valve body. When the rotor is placed in selected positions
- ◆ inlet and outlet ports are connected in various combinations permitting the start,
- ◆ stop or directional change of fluid under pressure.
- ◆ The functions specific to a valve primarily on rotor type selected。
  
- ◆ Features:
- ◆ Provides a fast and positive control of oil to and from cylinders and motors.
- ◆ Customers can select from one of three spool types allowing flow to be diverted from
- ◆ one line to another or in neutral position of pressure to tank.

### 型号说明/MODEL CODE

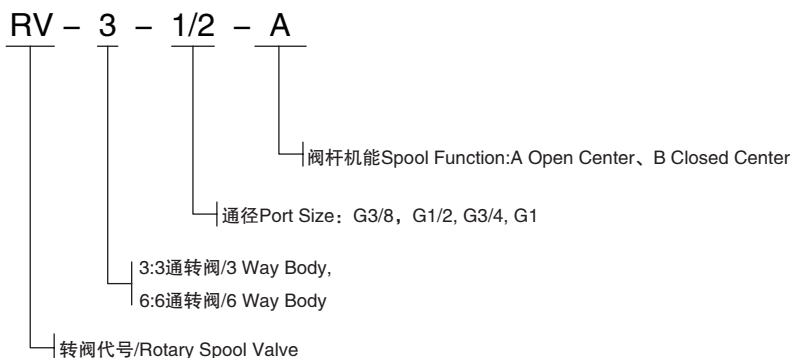

### 技术参数/PARAMETERS

油口 PORT SIZE	流量 Flow Rate/LPM	压力 Pressure/Mpa	阀芯机能 Spool Function	重量 Weight/kgs
G3/8	60LPM	32	Closed Center and Open Center	1.5
G1/2	90LPM	32		2
G3/4	140LPM	32		3
G1	200LPM	32		4

注：订货有特殊要求者，请与销售顾问联系。

Note: Special features not listed can often be made to your specifications. Please consult your sales representative.

# RV系列转阀

## RV Solenoid Diverter Valve

### RV外形安装连接尺寸/MODELR RV DIMENSIONAL DATA

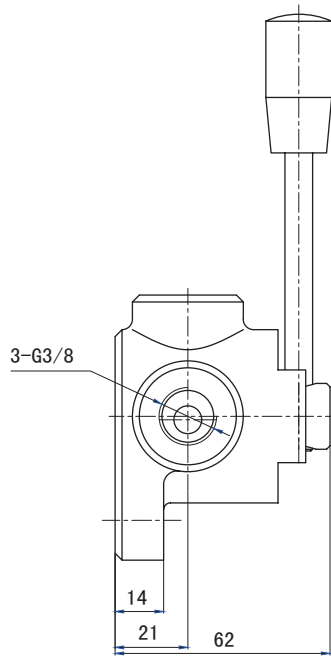
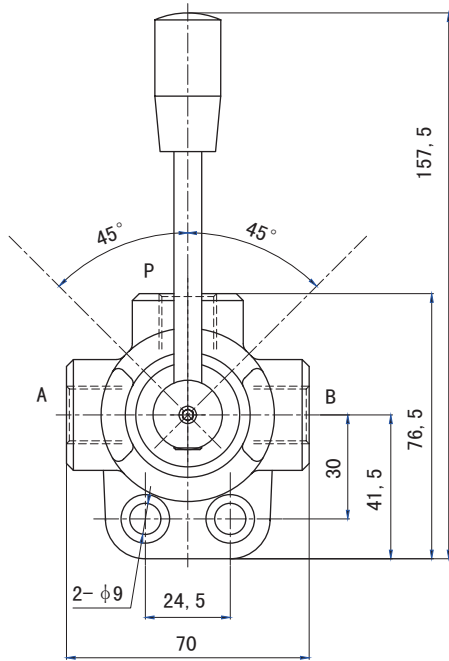

技术参数

1. 最大流量: 60L/min
2. 最大压力: 31.5MPa
3. 油口螺纹: G3/8

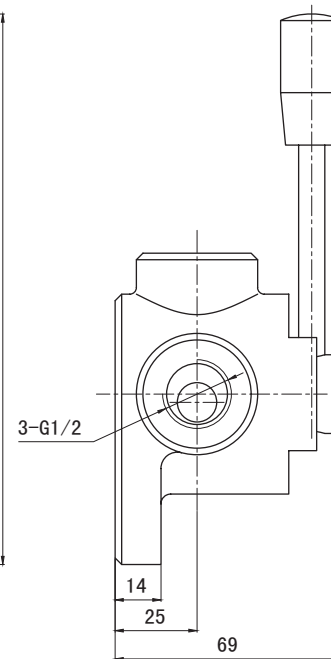
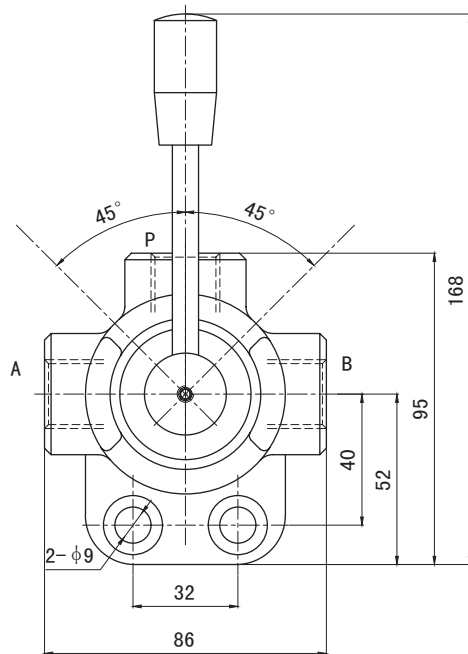

技术参数

1. 最大流量: 90L/min
2. 最大压力: 31.5MPa
3. 油口螺纹: G1/2

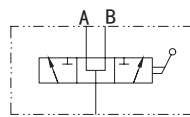

A型机能

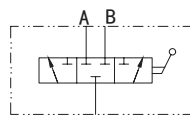

B型机能

c10

RV转阀 Rotary Spool Valve

# RV系列转阀

## RV Solenoid Diverter Valve

### RV外形安装连接尺寸/MODELR RV DIMENSIONAL DATA

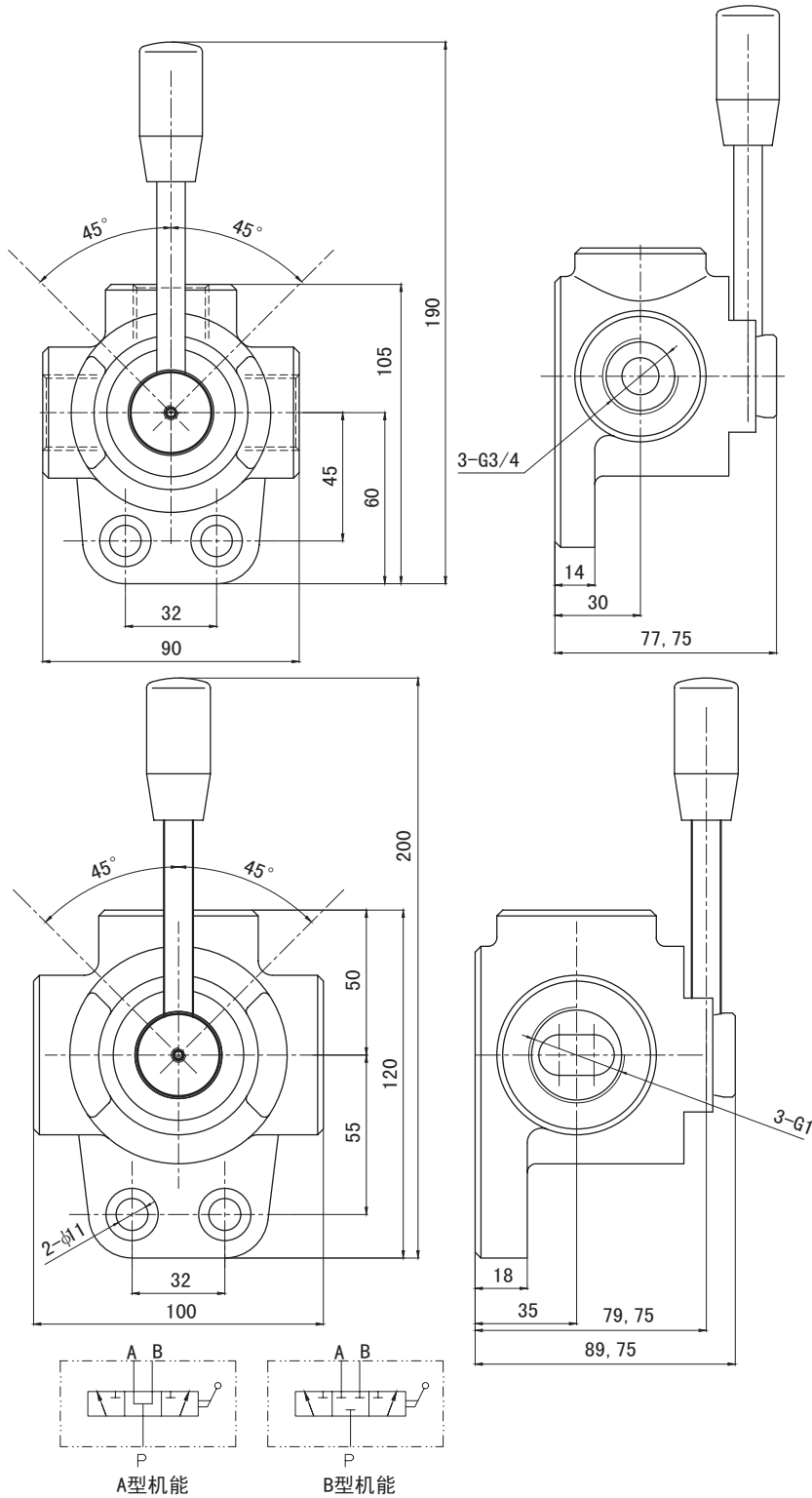

技术参数

1. 最大流量: 120L/min
2. 最大压力: 31.5MPa
3. 油口螺纹: G3/4

技术参数

1. 最大流量: 200L/min
2. 最大压力: 25MPa
3. 油口螺纹: G1

# ZP80系列整体阀

## ZP80 Series Monoblock Directional Control Valves

### 产品描述/SPECIFICATION

ZP80系列是我公司自主研发设计的一种中高压整体式多路阀。ZP80的阀芯机能有O, Y, A等。

该阀广泛应用于工程机械、环卫机械、矿山机械和其他机械的液压系统。

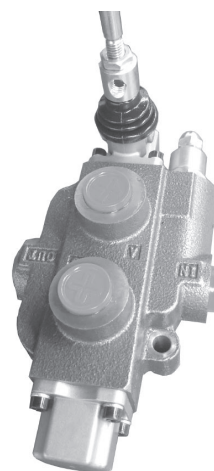

### 产品特点/FEATURES

- ◆ 安全阀：阀体内置溢流阀，可调节控制系统压力
- ◆ 油路形式：并联油路
- ◆ 控制方式：手动换向
- ◆ 阀体结构：整体结构，1连。
- ◆ 阀杆机能：O、A、Y等
- ◆ Relief valve: The relief valve inside the valve body is able to adjust the hydraulic system working pressure.
- ◆ Oil way: Parallel circuit.
- ◆ Control Way: manual control
- ◆ Valve construction: monoblock construction, 1 lever
- ◆ Spool Function: O,A,Y etc.

### 型号说明/MODEL CODE



### 技术参数/PARAMETERS

公称压力 (MPa) Nom. Pressure	最大压力 (MPa) Max. Pressure	公称流量 (L/min) Nom. Flow rate	最大流量 (L/min) Max. Flow rate	中位背压 (MPa) Back Pressure	工作油液hydraulic oil		
					温度范围 (℃) Tem.rang	粘度范围 (mm <sup>2</sup> /S) Visc.rang	过滤精度 (μm) filtrating accuracy
20	31	80	80	≤1	-20 ~ +80	10 ~ 400	≤10

# ZP80 系列整体阀

## ZP80 Series Monoblock Directional Control Valves

### ZP80外形安装连接尺寸/MODEL ZP80 DIMENSIONAL DATA

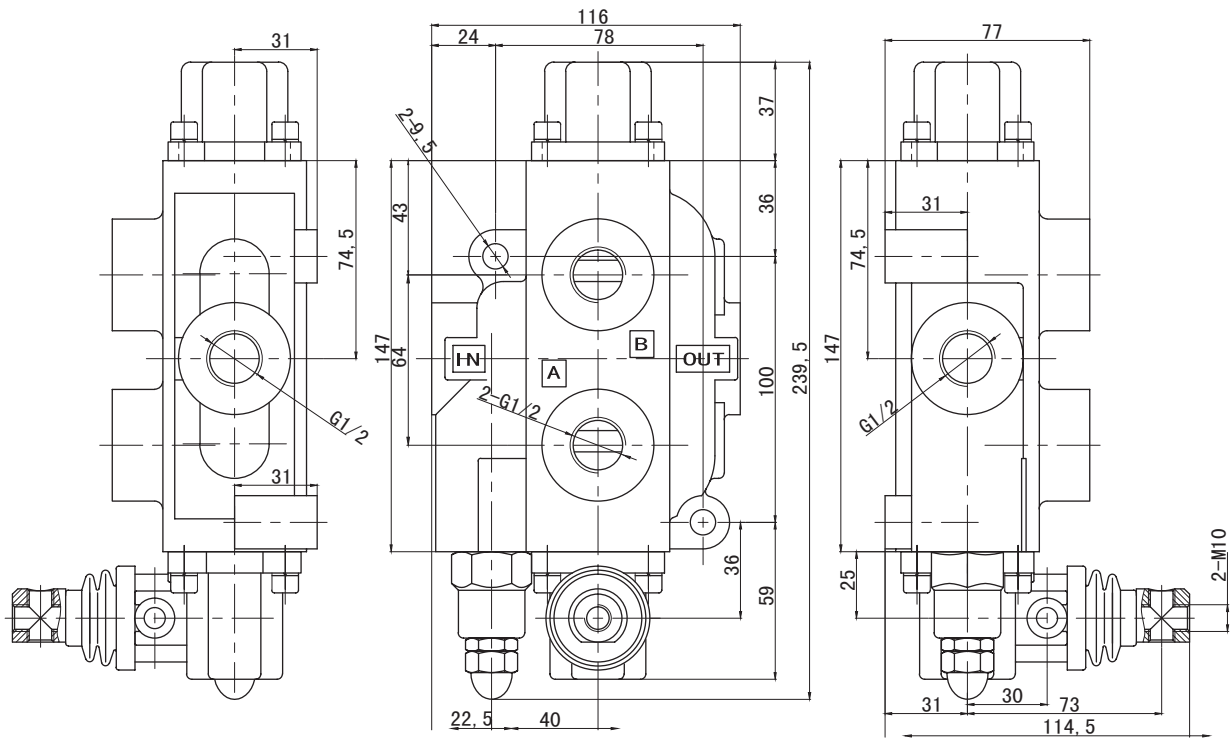

原理图

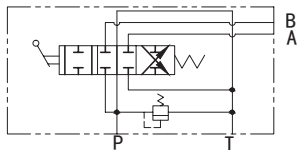

技术参数:

1. 公称压力 20MPa
2. 额定流量 80L/min

c13

ZP80系列整体阀MDCV